

# 5G MEC/Slice System to Support Cloud Gaming, HD Video and Live Broadcasting Blueprint

Zhiqiang You, [jordyyou@tencent.com](mailto:jordyyou@tencent.com)  
Wei Chen, [allenwchen@tencent.com](mailto:allenwchen@tencent.com)  
Tencent

# Blueprint Proposal: 5G MEC/Slice system to support Cloud Gaming, HD Video and Live broadcasting

Case Attributes	Description	Informational
Type	New Blueprint for 5G MEC/Slice system to support Cloud Gaming, HD Video and Live broadcasting	
Blueprint Family - Proposed Name	It is still a independent blueprint	
Use Case	<ol style="list-style-type: none"> <li>1. Small deployment targeting MEC in access sites or enterprise</li> <li>2. Medium deployment targeting MEC in central offices</li> </ol>	
Blueprint proposed Name	5G MEC/Slice system to support Cloud Gaming, HD Video and Live broadcasting	
Initial POD Cost (capex)	The minimal configuration is 5 servers in total: 5G system, MEC PaaS(1 Server), Application Server (1 Server)	
Scale & Type	Up to 2 x86/arm servers	
Applications	Any application requires high bandwidth and low latency, including but not limited to : <ol style="list-style-type: none"> <li>1) Cloud Gaming</li> <li>2) HD Video</li> <li>3) Live broadcasting</li> </ol>	
Power Restrictions	Less than 10Kw	
Infrastructure orchestration	Cloud Infrastructure & Orchestrator: OpenStack/StarlingX PaaS: K8s/Docker Swarm OS - Ubuntu 16.x, Centos7 Hypervisor: KVM/QEMU Network: VPP, F-Stack SDN: SR-IOV, OVS-DPDK, VPP-DPDK	
Workload Type	Bare Metal, VM or Container	
Additional Details	Cloud Gaming, HD video or Live broadcasting applications may enable support for high density media streaming processing via GPU or FPGA acceleration	

# Architecture Overview

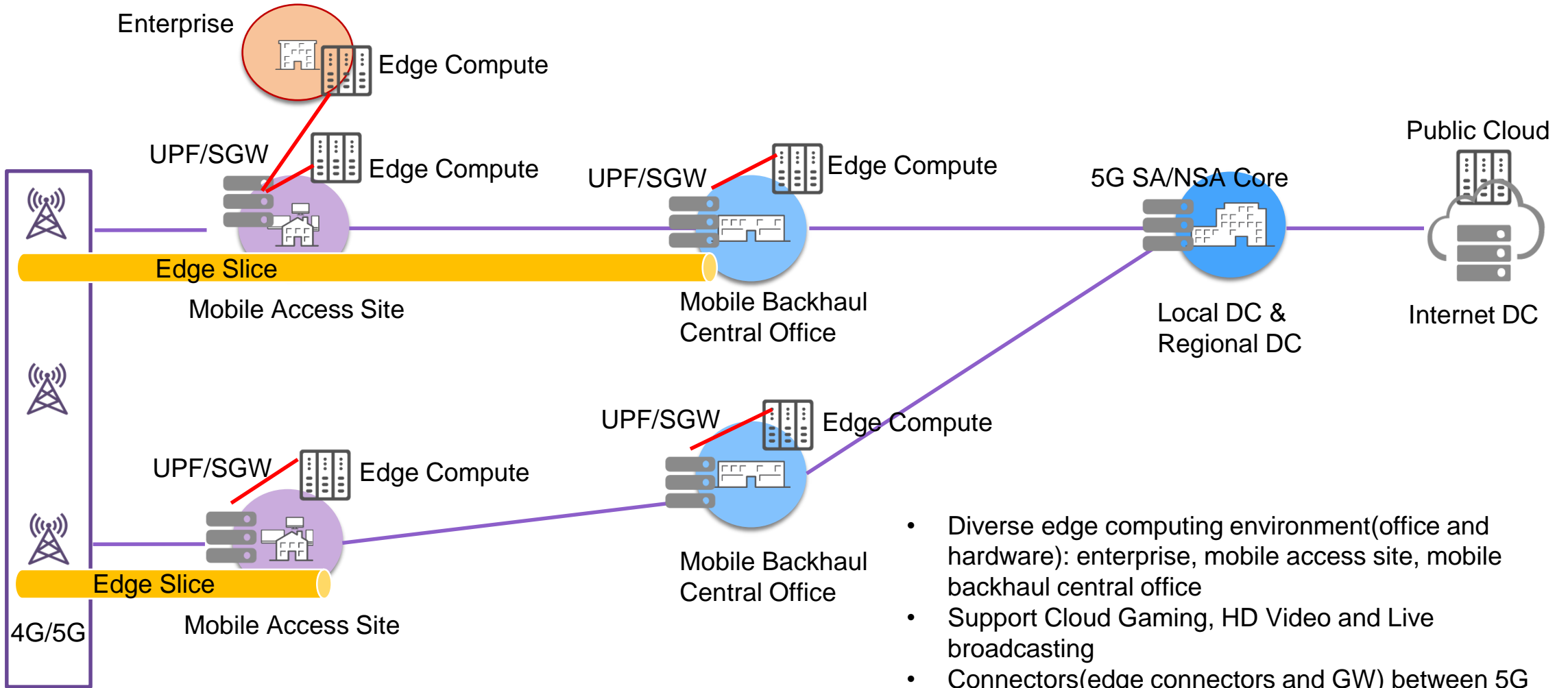

- Diverse edge computing environment (office and hardware): enterprise, mobile access site, mobile backhaul central office
- Support Cloud Gaming, HD Video and Live broadcasting
- Connectors (edge connectors and GW) between 5G and applications to enable edge computing to enable dynamic traffic offloading and management
- Support edge slice to guarantee service experience

# Architecture Overview

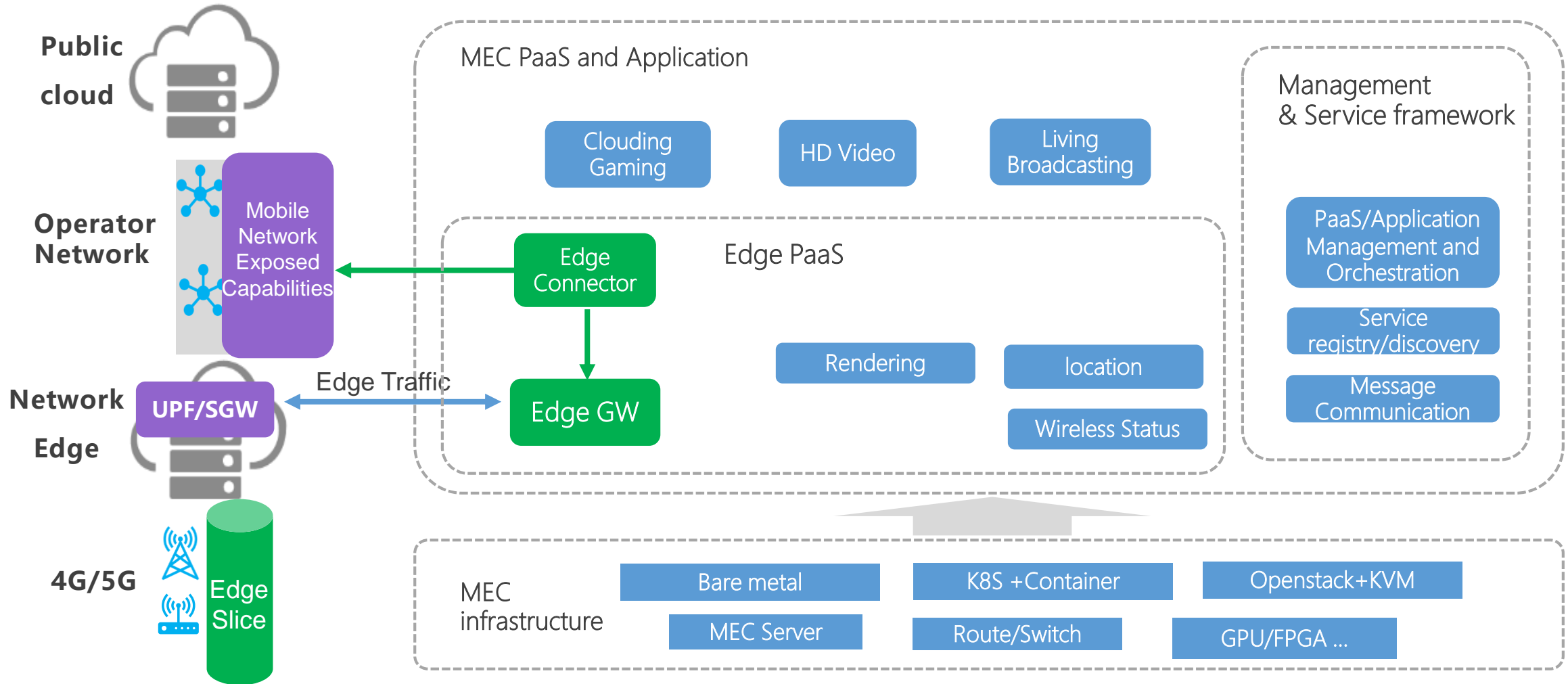

- Edge connector: enable the traffic offloading from the aspects of control interaction with mobile network exposed capabilities, and subscribe the edge slice between UE and edge application
- Edge GW: enable the traffic offloading from the aspects of data plane with load balance, application proxy, traffic management, local traffic routing

# Key Edge Applications: Cloud Gaming

	Traditional Gaming	Cloud Gaming
Promoting	Takes a <b>fair amount of time</b> to download. Users may not willing to wait.	Takes only <b>few seconds</b> to download, "Click and Play".
Latency	With traditional or 4G network, the low bandwidth and latency (around <b>80ms</b> ) does not deliver the best user experience.	With the 5G network, the user is guaranteed with a <b>25Mbps to 100Mbps</b> bandwidth and the latency is reduced to <b>10ms to 20ms</b> .
System Requirement	The <b>users have to make sure</b> their device meets the system requirements to get the best user experience.	The <b>users do not need to worry</b> about the hardware requirement.



# Key Edge Applications: HD Video and Live broadcasting

## Live Broadcast

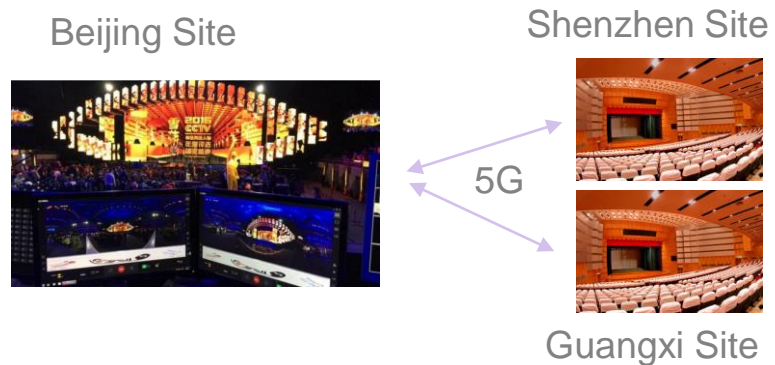

- 20Mbps~50Mbps per channel video
- 20ms delay to support interactive behavior

## HD Video

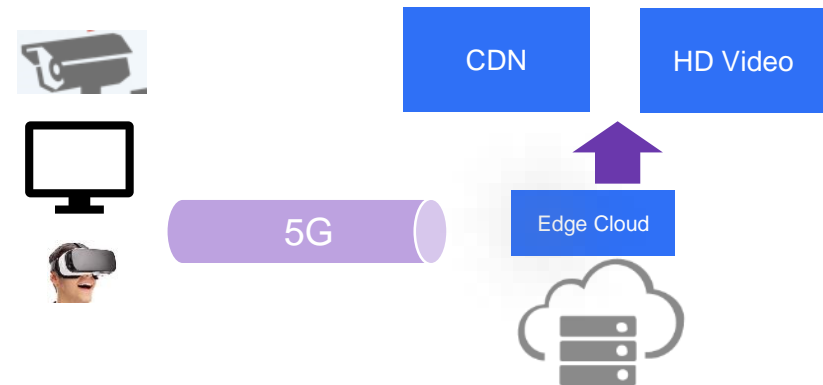

- 8K video 100Mbps+

# Initial Detailed Technical Architecture for Edge Connector and Edge GW

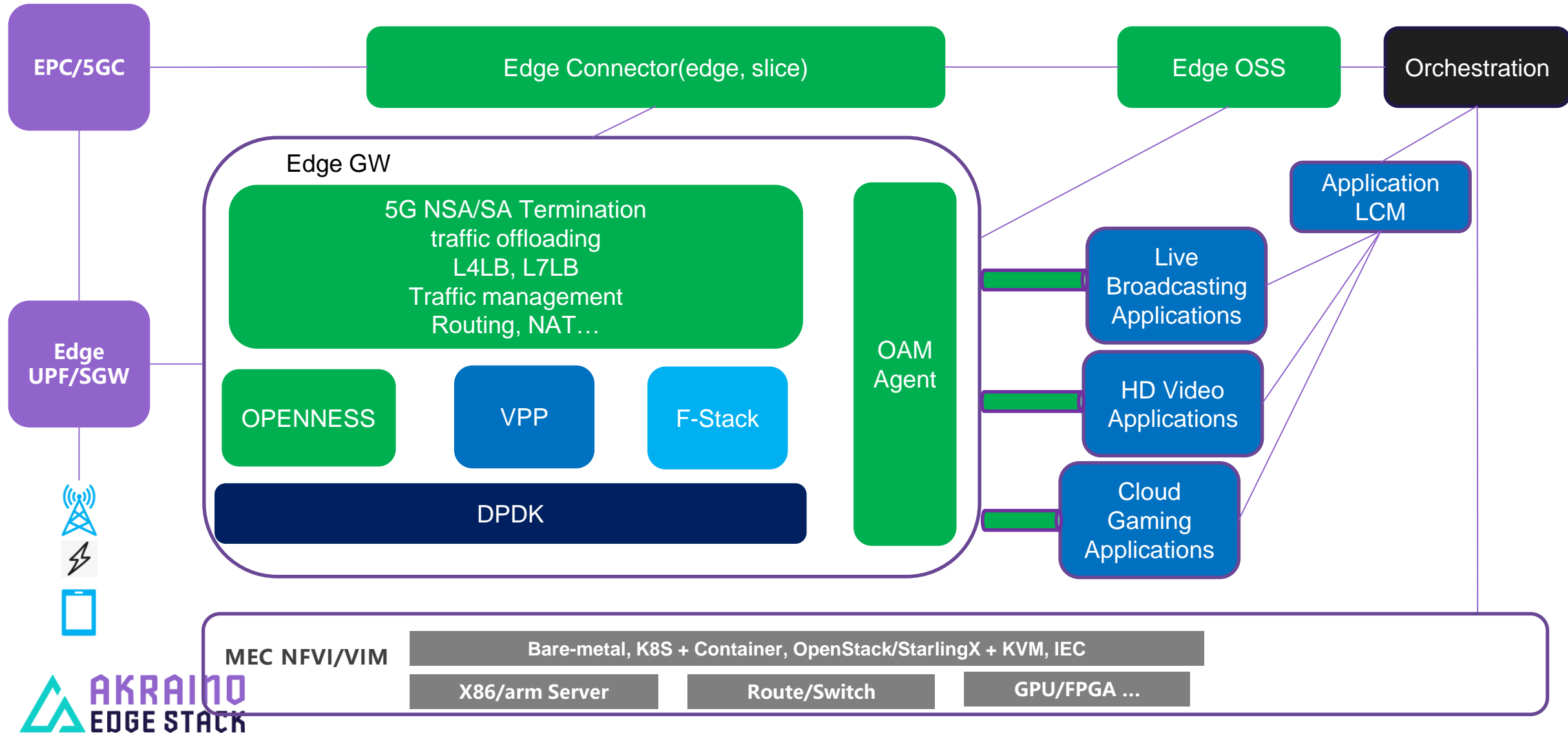

Thanks!