

**6G selected Architecture Themes  
Sensing Networks through 3GPP PlIoT  
(PINs), ETSI SAREF eHAWs, 3GPP Core  
RAN Synergy (& Cell Free Solution)  
to  
LF Edge Akraino TSC**

**Ike Alisson  
LF Edge Akraino Documentation  
Sub-committee TSC Chair**

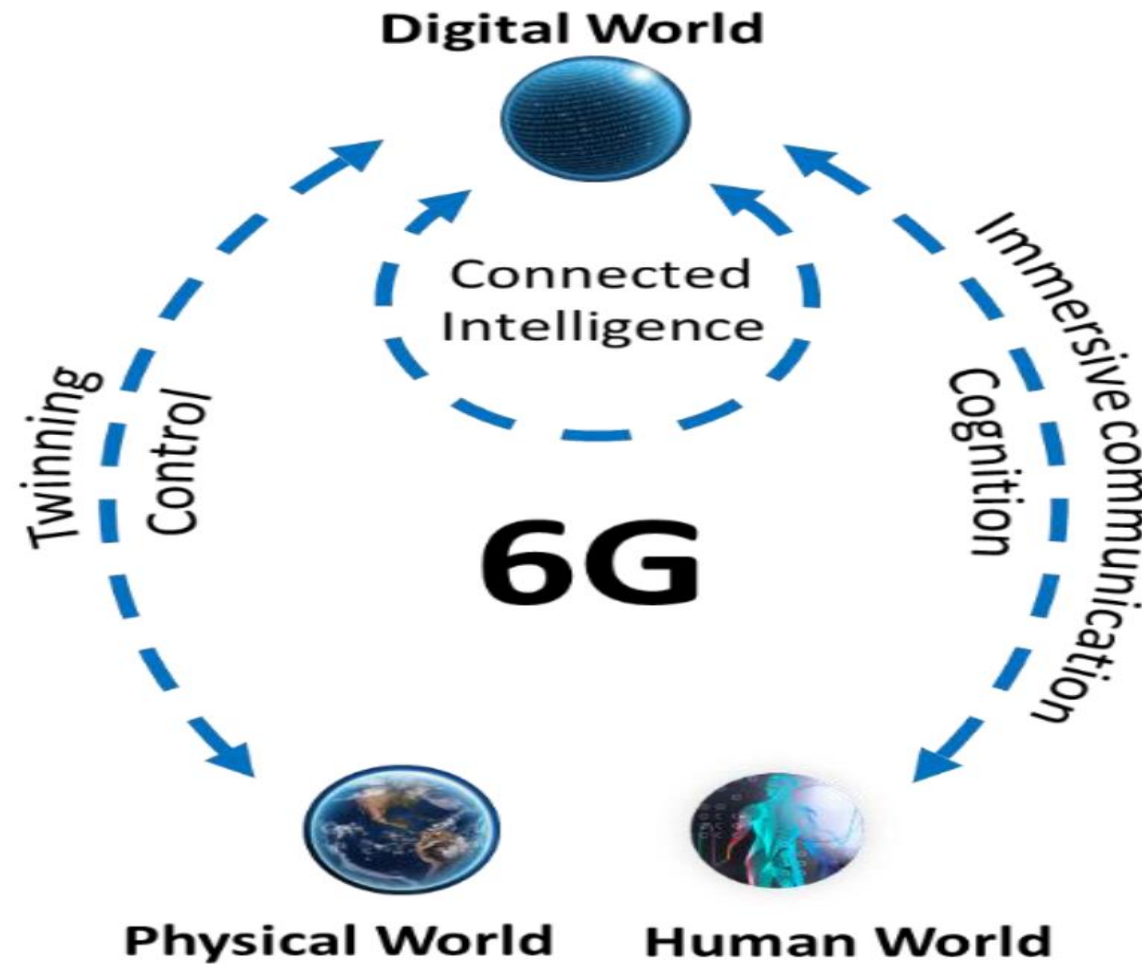
**2021-06-29  
Rev PA10**



## Table of Contents

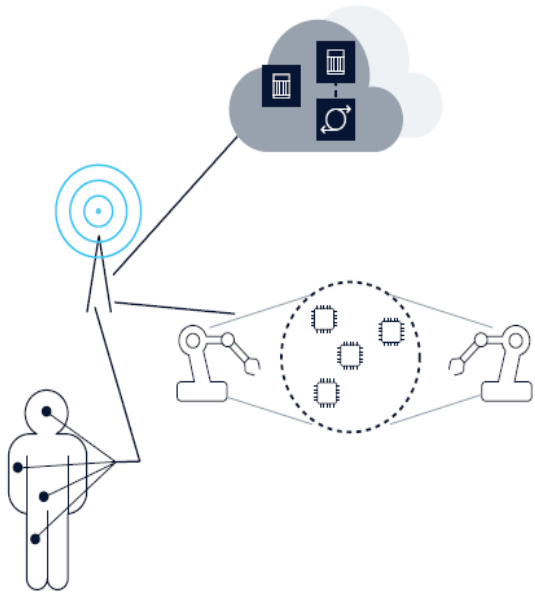
1. Overview of the Presentation sections
2. 6G overview
3. Sensing Networks through 3GPP PloTs/PINs & ETSI SAREF eHAW
4. 6G RAN Core Convergence
5. Cell Free Solution overview





**Figure 3.1:** Convergence of digital, physical, and personal domains.

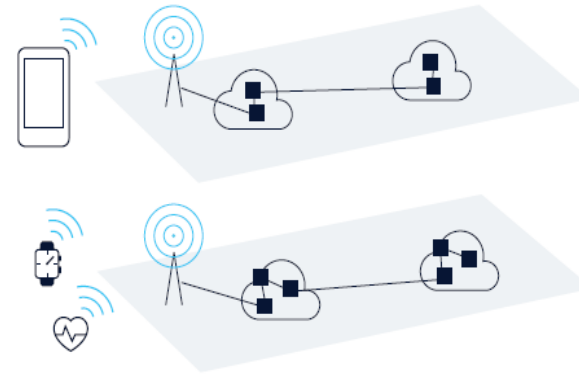
## 6G Architecture Themes



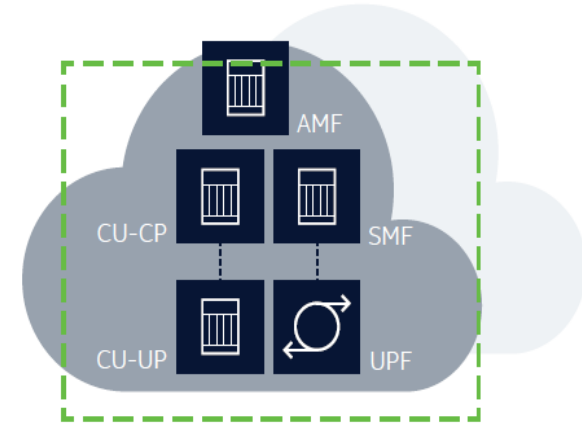
End point is a network



Cell free/mesh



Hyper-specialized slicing

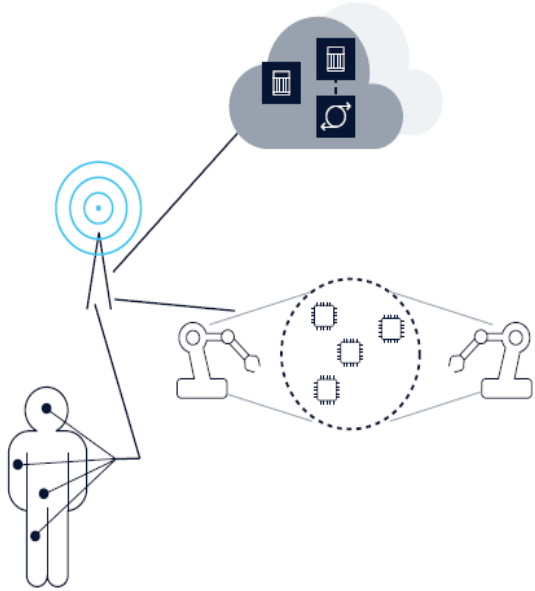


RAN-Core convergence

1

2

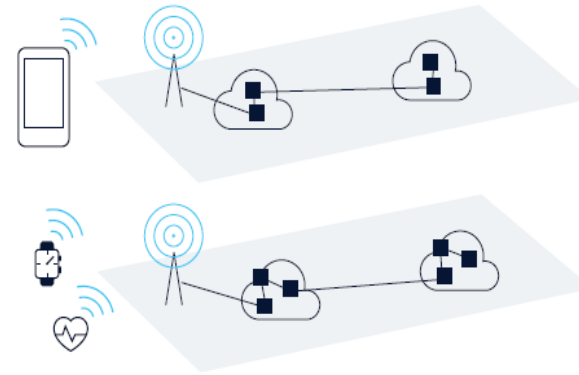
### 6G Architecture Themes



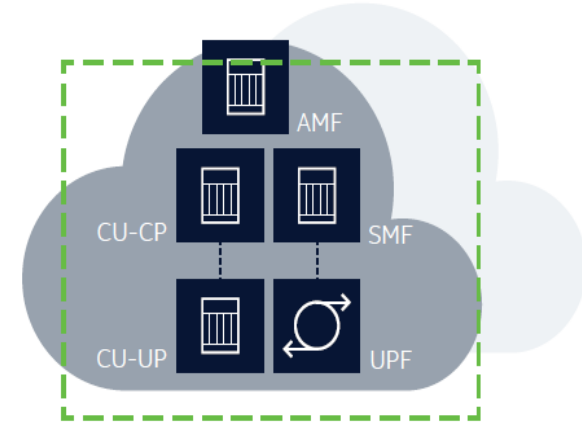
End point is a network



Cell free/mesh



Hyper-specialized slicing



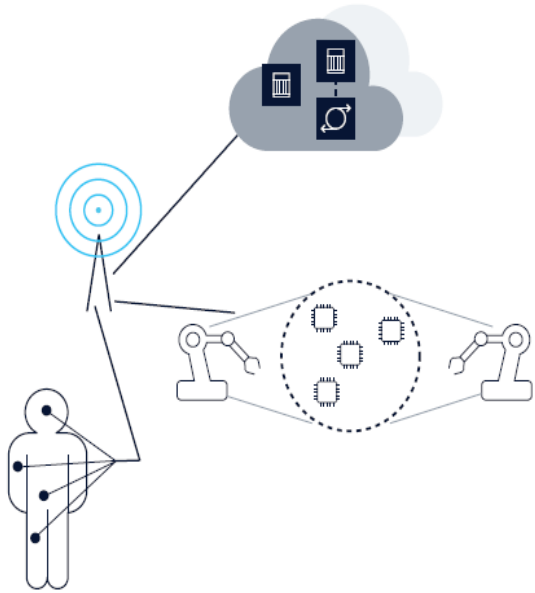
RAN-Core convergence

1

3

2

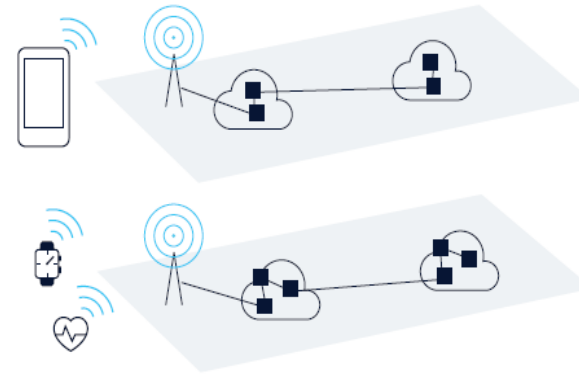
### 6G Architecture Themes



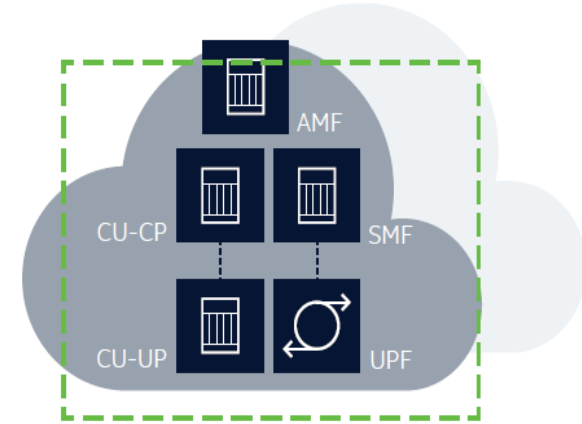
End point is a network



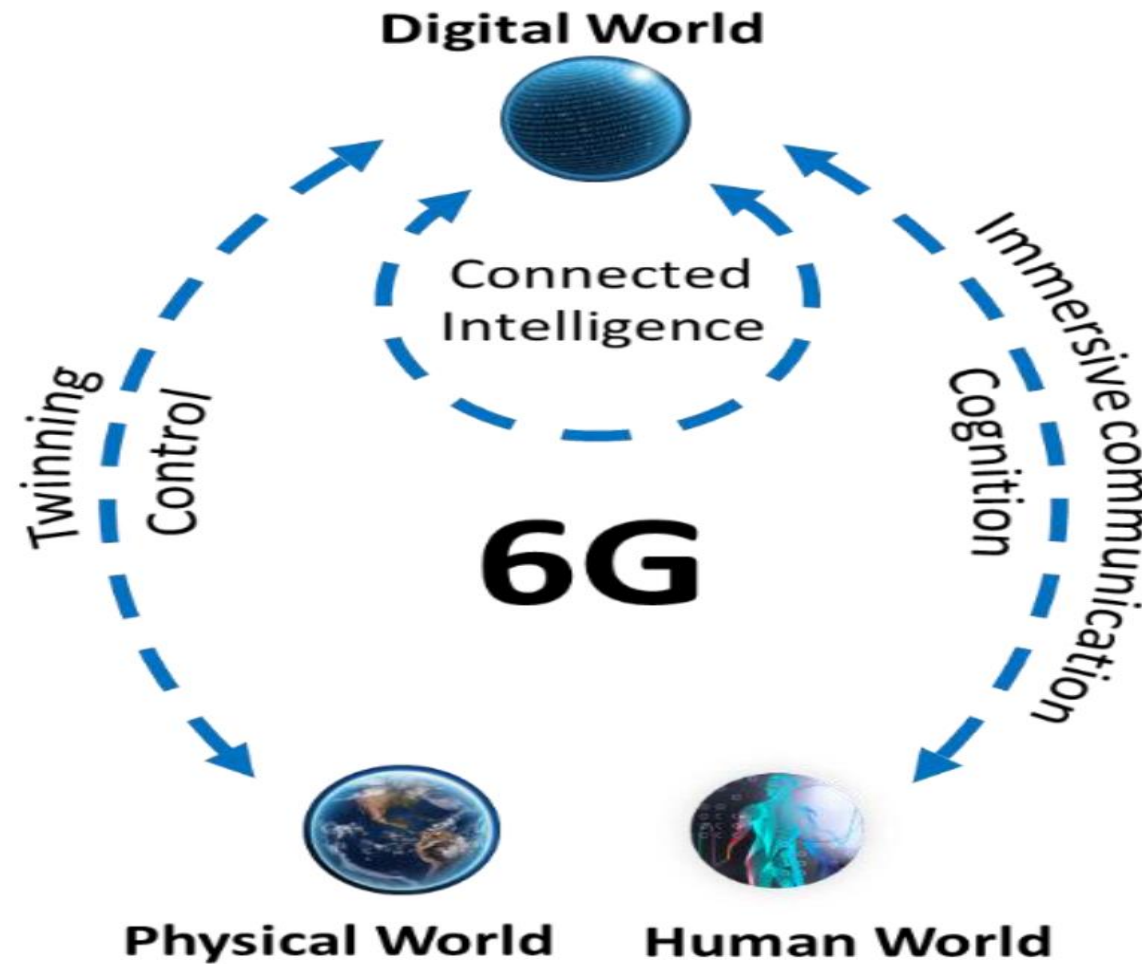
Cell free/mesh



Hyper-specialized slicing



RAN-Core convergence



**Figure 3.1:** Convergence of digital, physical, and personal domains.

## Main 6G Goals

Connecting intelligence

Programmable

Determinism

Integrated sensing

Sustainable

Trustworthiness

Affordable and Scalable

## Improving 5G

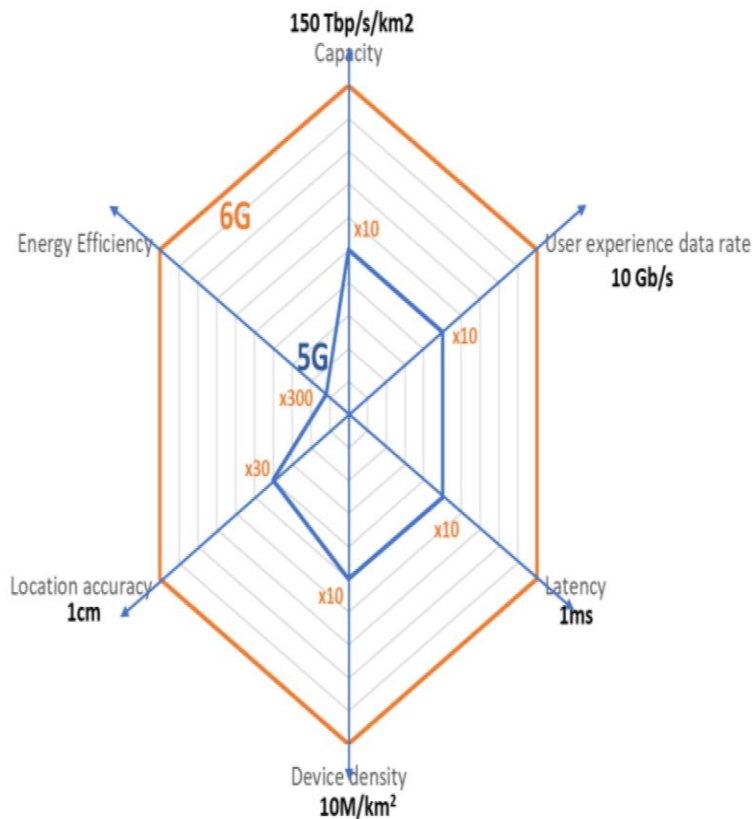


Figure 3.3: 6G goals.

## Requirements

Connecting intelligence

Programmable

Determinism

Integrated sensing

Sustainable

Trustworthiness

Affordable and scalable

## AI/ML assisted

Network Architecture & Control

Edge & Ubiquitous Computing

Radio Technology & Signal Processing

Optical Networks

Network & Service Security

Non-Terrestrial Communication

Devices & Components

## KPIs

Energy efficiency

Spectral efficiency

Throughput (e.g., Tbps)

Reliability (e.g., 1-10<sup>-9</sup>)

Latency (e.g., sub-ms)

Positioning (e.g., cm level)

Density

Coverage

Privacy

Cost

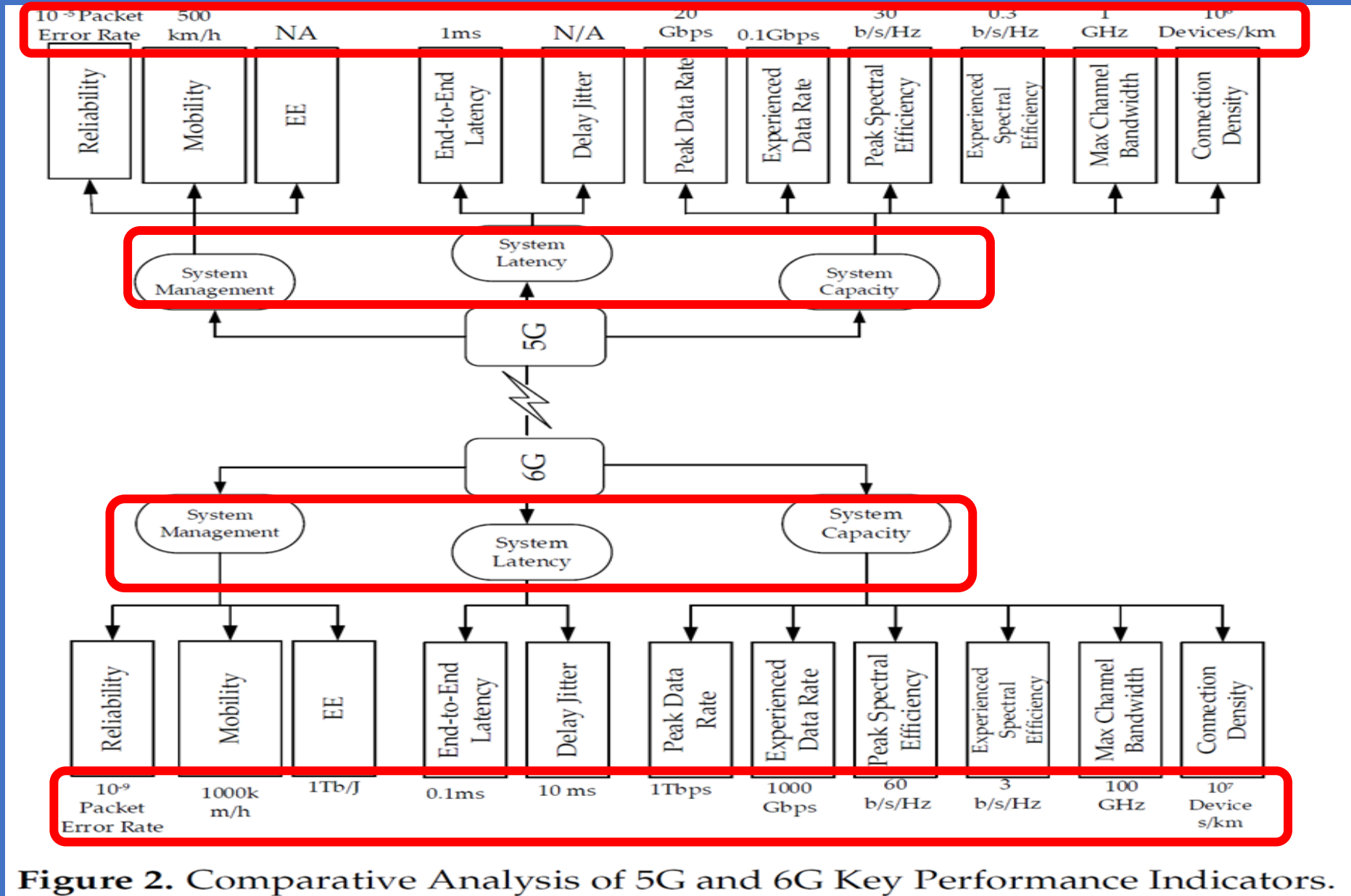
Figure 4.1: Technology areas with strong impact on different 6G requirements and KPIs.



**Table 3.** A comparative analysis of 5G, B5G, and 6G.

Description	5G	Beyond 5G	6G
Frequency bands	<ul style="list-style-type: none"> <li>■ Sub-6GHz</li> <li>■ mmWave for fixed access</li> </ul>	<ul style="list-style-type: none"> <li>■ Sub-6GHz</li> <li>■ mmWave for fixed access</li> </ul>	<ul style="list-style-type: none"> <li>■ Sub-6GHz</li> <li>■ mmWave for mobile access</li> <li>■ Exploration of higher frequency and THz bands (above 300 GHz)</li> <li>■ Non-RF (optical, VLC)</li> </ul>
Rates requirements	20 Gb/s	100 Gb/s	1 Tb/s
Radio only delay requirements	100 ns	100 ns	10 ns
End-to-End delay(latency) requirements	5 ms	1 ms	<1 ms
Processing delay	100 ns	50 ns	10 ns
Device types	<ul style="list-style-type: none"> <li>■ Sensors</li> <li>■ Smartphones</li> <li>■ Drones</li> </ul>	<ul style="list-style-type: none"> <li>■ Sensors</li> <li>■ Smartphones</li> <li>■ Drones</li> <li>■ XR equipment</li> </ul>	<ul style="list-style-type: none"> <li>■ Sensors and DLT</li> <li>■ CRAS</li> <li>■ XR and BCI</li> <li>■ Smart implants</li> </ul>
Architecture	<ul style="list-style-type: none"> <li>■ Dense sub-6 GHz small base stations with umbrella macro stations.</li> <li>■ mmWave small cells of about 100 m (about fixed access).</li> </ul>	<ul style="list-style-type: none"> <li>■ Denser sub-6 GHz small cells with umbrella macro base stations.</li> <li>■ &lt;100 m tiny and dense mmWave cells.</li> </ul>	<ul style="list-style-type: none"> <li>■ Cell-free smart surfaces at high frequency supported by mmWave tiny cells for mobile and free access.</li> <li>■ Temporary hotspots are served by drone-carrier base stations or tethered balloons.</li> <li>■ Trials of tiny THz cells.</li> </ul>
Services	<ul style="list-style-type: none"> <li>■ eMBB</li> <li>■ URLLC</li> <li>■ mMTC</li> </ul>	<ul style="list-style-type: none"> <li>■ Reliable eMBB</li> <li>■ URLLC</li> <li>■ mMTC</li> <li>■ Hybrid (URLLC + eMBB)</li> </ul>	<ul style="list-style-type: none"> <li>■ HCS</li> <li>■ MPS</li> <li>■ MBRLLC</li> <li>■ mURLLC</li> </ul>

# 5G and 6G KPIs Comparison



**Figure 2. Comparative Analysis of 5G and 6G Key Performance Indicators.**

# Trends towards 6G

**Table 6.** A summary of the driving trends towards 6G wireless networks.

Driving Trends	Description
The convergence of Communications, Computing, Control, Localization, and Sensing (3CLS).	Provides computing, control, localization, and sensing in addition to Wireless Communication that previous generations provided. Supports applications such as XR, CRAS, DLS.
The emergence of Smart Reflective Surfaces and Environments.	Driven by smart reflective surfaces that serve as walls, roads, doors, and entire buildings, help maintain a line of sight and obtain a quality signal with minimal loss.
Massive Availability of Small Data.	The shift from centralized big data to massive distributed small data.
More bits, More spectrum, and More Reliability.	Exploring higher frequency spectrum (THz), which is proposed to facilitate the actualization of 1 Tb/s.
From Self-Organizing Networks to Self-Sustaining Networks.	AI is proposed to facilitate intelligent wireless networks that are self-sustaining.
Ubiquitous connectivity that encompasses air, ground, and undersea.	6G is envisioned to integrate space-air-ground-sea mode to facilitate wireless communication in flying vehicles, XR, BCI, and more.
The emergence of Haptics and the End of Smartphone era.	The pervasive use of wearables and implants, supported by BCI and XR.



Figure 3. 6G Driving Trends.

# Samsung's 6G Vision

Today's exponential growth of advanced Technologies such as AI, Robotics, & Automation will usher in unprecedented paradigm shifts in the Wireless Communication.

These circumstances lead to four (4) major Megatrends advancing toward 6G:

1. Connected Machines,
2. Use of AI for the Wireless Communication,
3. Openness of Mobile Communications, and
4. Increased contribution for achieving Social Goals.

**Figure 1**

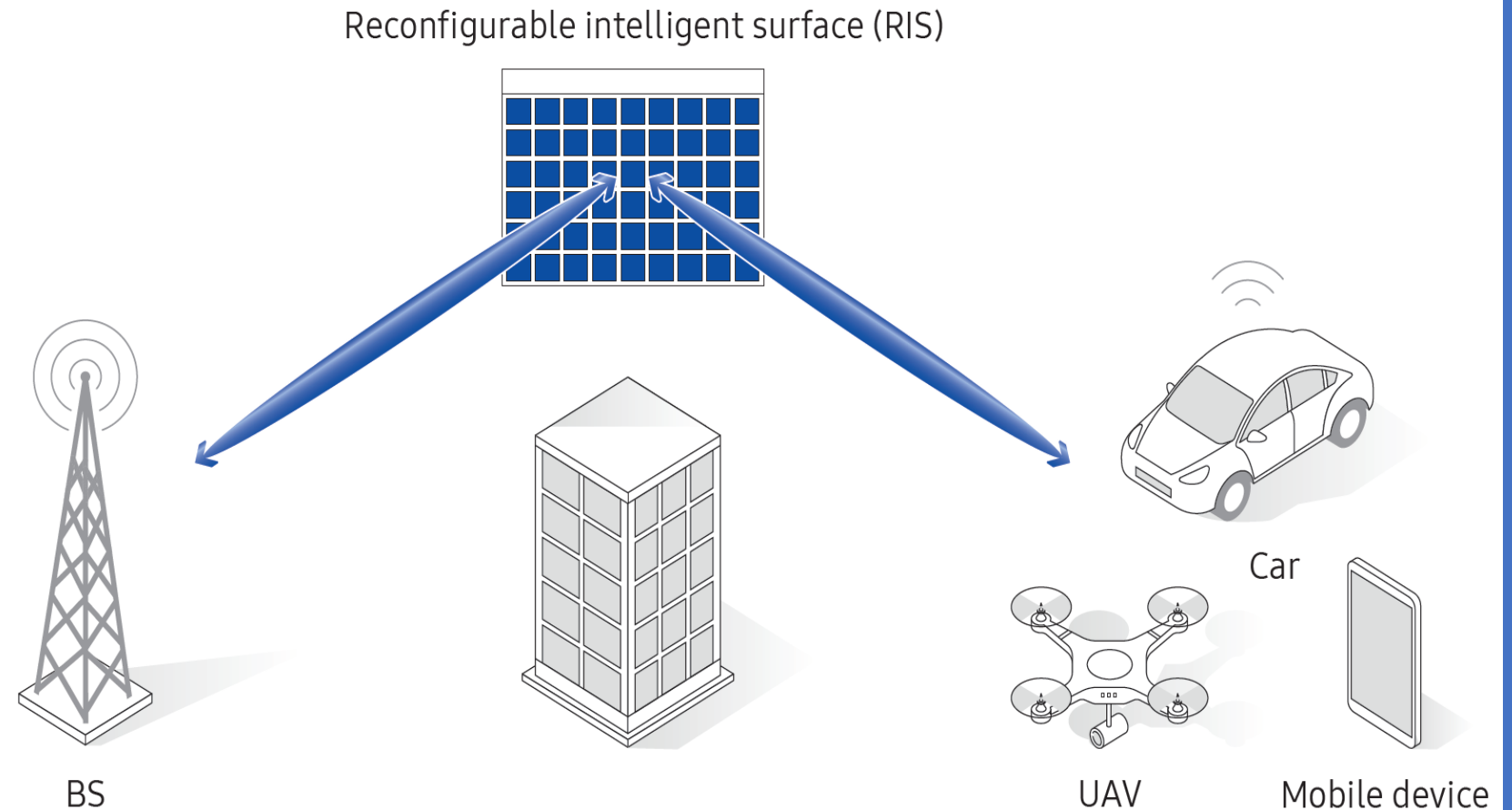
Evolution of mobile devices and connected machines.



- *Reconfigurable intelligent surface (RIS)* can be used to provide a propagation path where no LoS link exists [25]. An example of signal reflection via RIS is illustrated in Figure 12.

**Figure 12**

RIS-aided communication between a BS and a mobile user, where the LoS path is blocked.

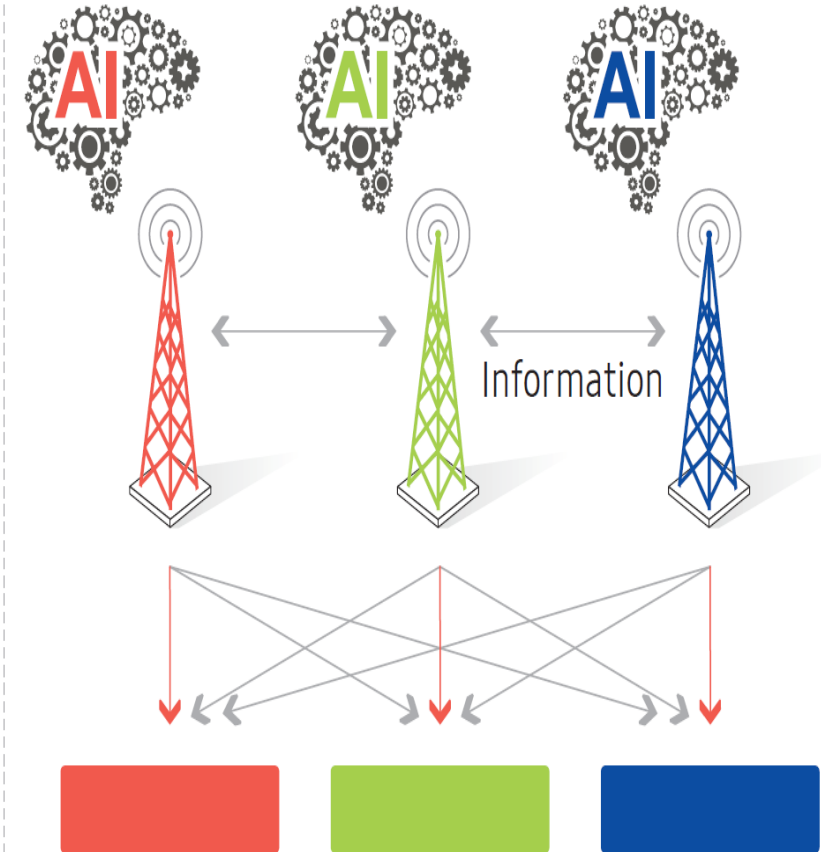
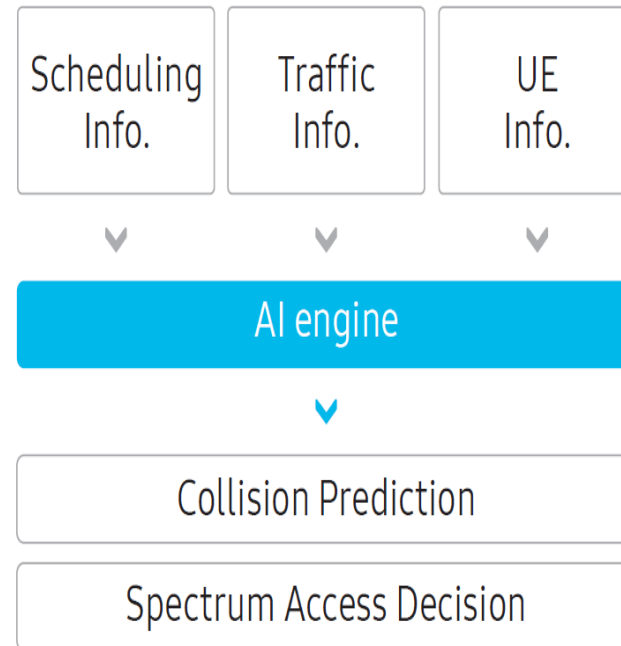


## Evolution of Duplex Technology (DSS)

The main challenge of the Dynamic Spectrum Sharing (DSS) is avoiding (or minimizing) collision of spectrum usage among different entities while allowing them to access spectrum in a dynamic manner. Theoretically, to prevent such collisions, network operators could exchange all relevant spectrum access information. In practice, however, this would not be possible because acquiring all required information for every entity in real time would impose an enormous communication overhead. AI could avoid collisions by predicting the spectrum usage of other entities with a limited amount of information exchanged, as illustrated in Figure 18.

Figure 18

Intelligent spectrum sharing.



## Comprehensive AI

AI receives much attention as a tool to solve problems that were previously deemed intractable due to their tremendous Complexity or the Lack of the necessary Model and Algorithm.

A comprehensive AI System to optimize the overall System Performance and Network Operation.

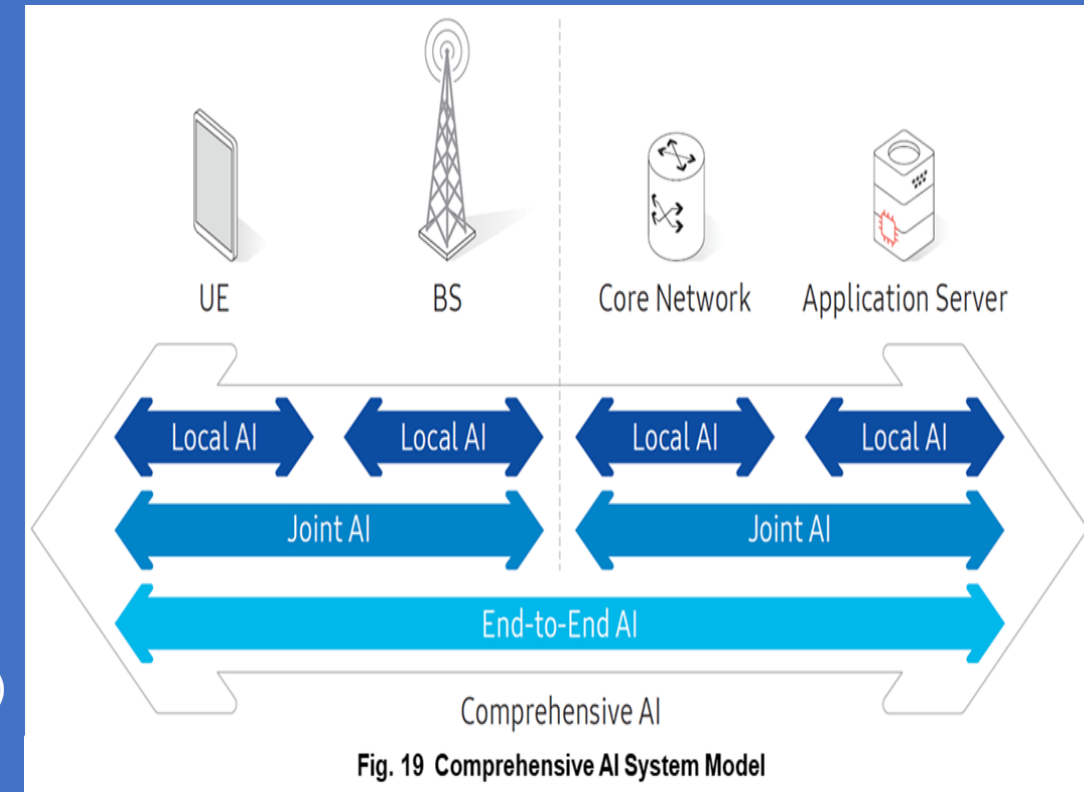
An overall Network Architecture consists of four (4) Tiers of Entities:

1. UE,
2. BS (BTS)
3. Core Network (CN), and
4. Application Server (AS).

Application of AI can be categorized into three (3) Levels (Fig. 19):

- 1) Local AI,
- 2) Joint AI,
- 3) E2E AI

There are ongoing efforts to introduce support for AI in standards. The 3GPP has standardized Network Data Analytics Function (NWDAF) for Data Collection & Analytics in Automated Cellular Networks.

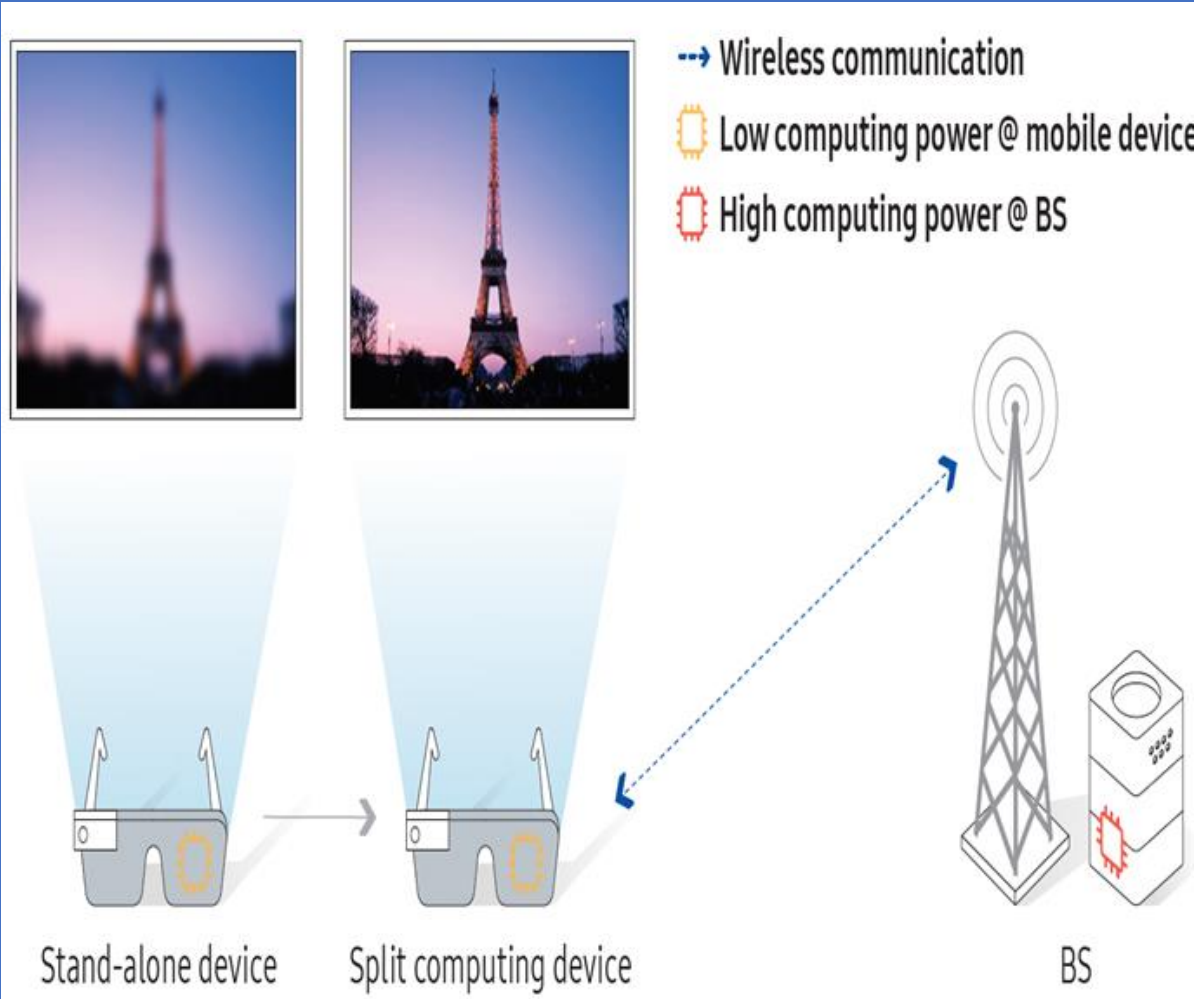


In addition to 3GPP, the O-RAN Alliance ushers in an open & efficient RAN leveraging AI Technologies.

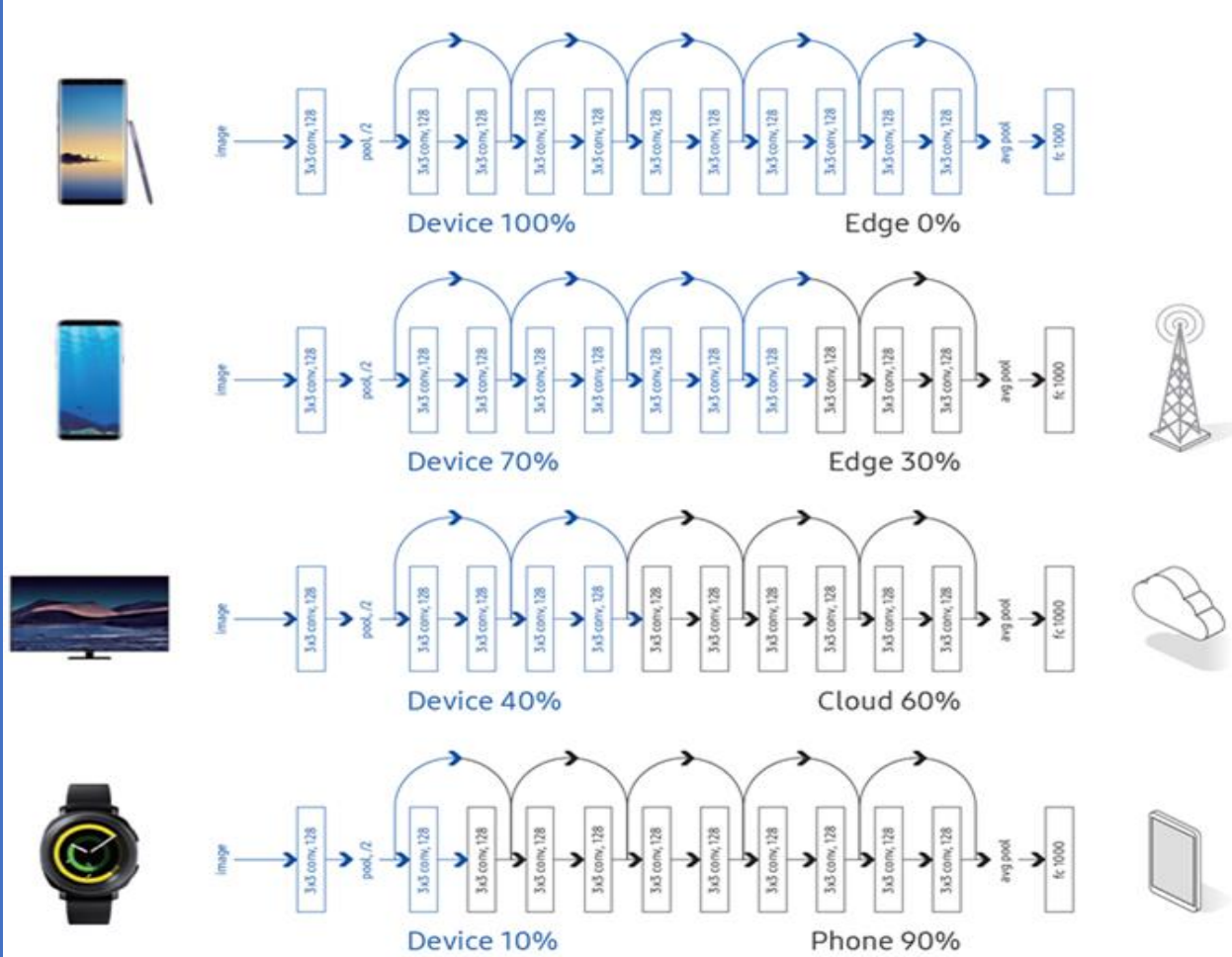
This effort, as we progress towards 6G, will result in Native Support of a Comprehensive AI System to realize more efficient, more reliable, & low cost communication systems.

## Split Computing

Future applications, such as truly immersive XR, mobile holograms, and digital replica, require extensive computation capabilities to deliver real-time immersive user experience. However, it would be challenging to meet such computational requirements solely with mobile devices, especially, given that many of future mobile devices will tend to become thinner and lighter. For example, AR glasses should be as light, thin, and small as regular glasses to meet the user's expectations.

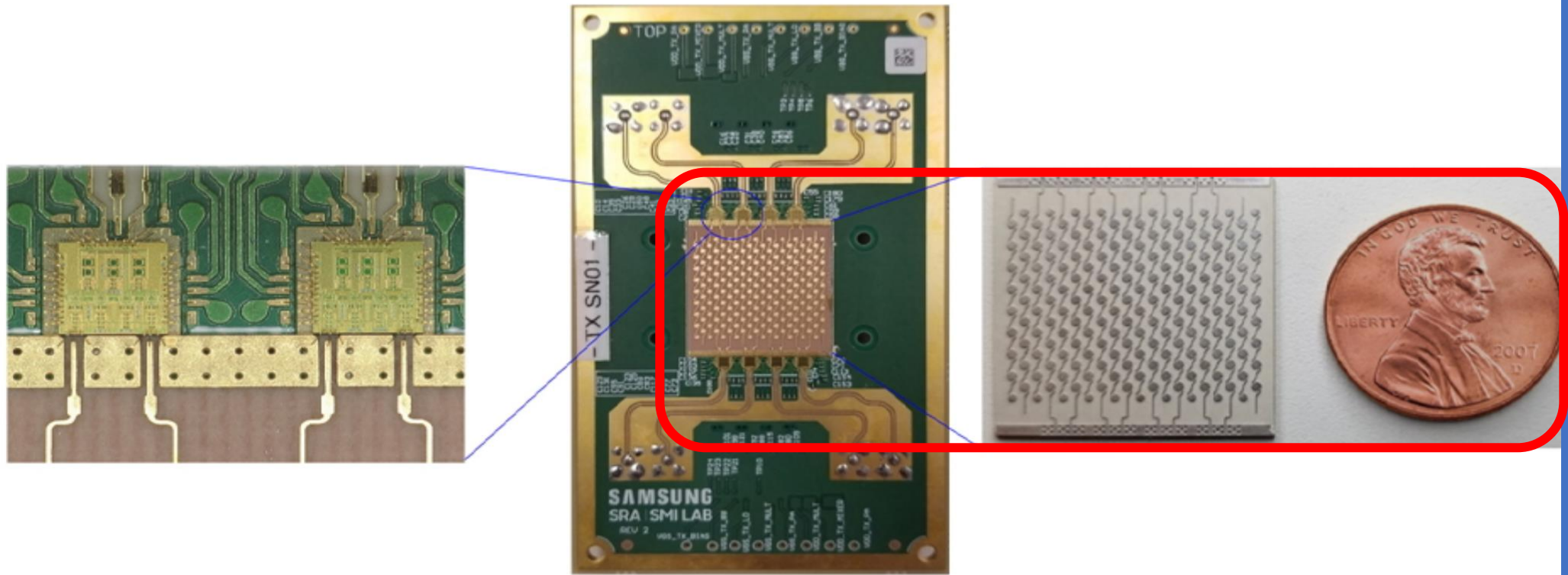


**Figure 20 Split Computing**

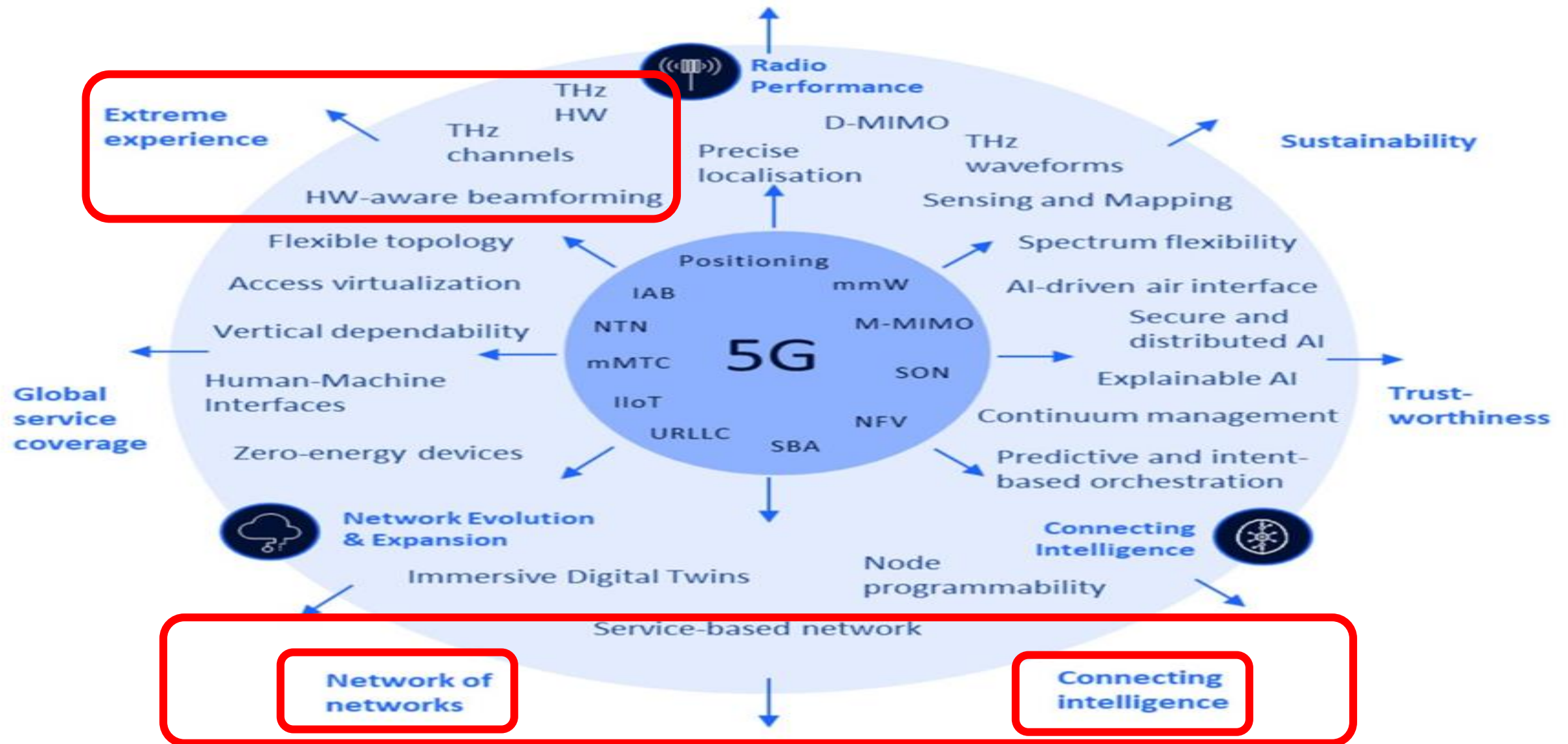


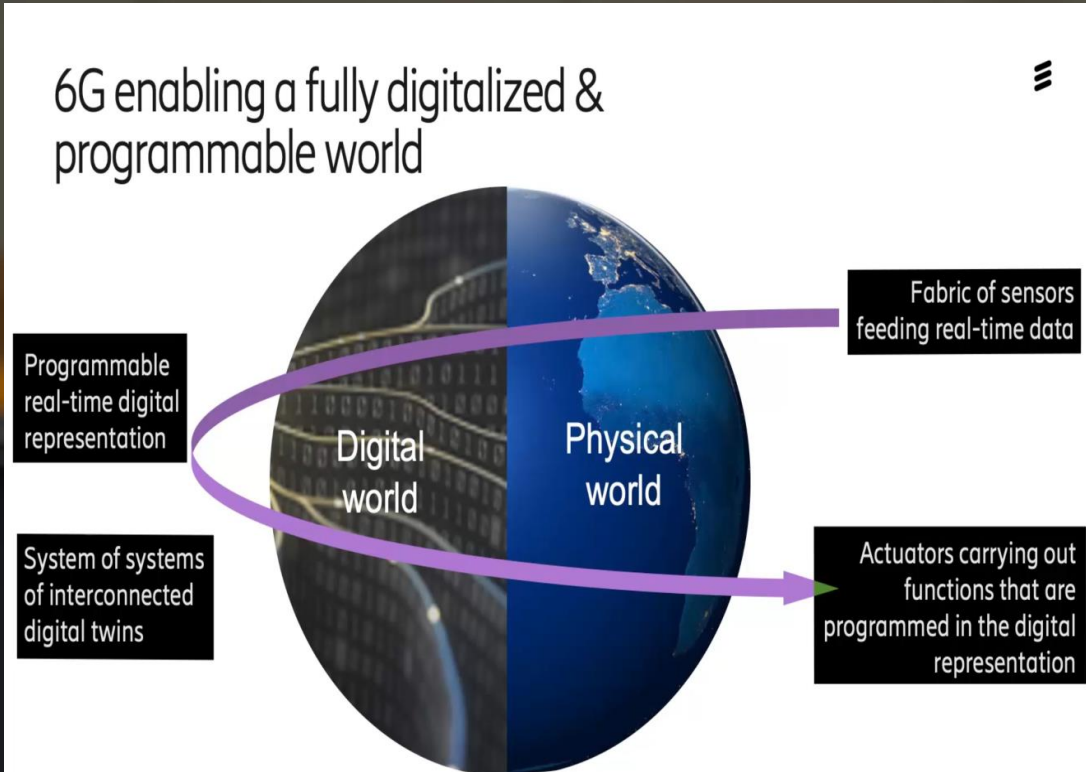
**Figure 21 Examples of Split Computing by Various Devices**





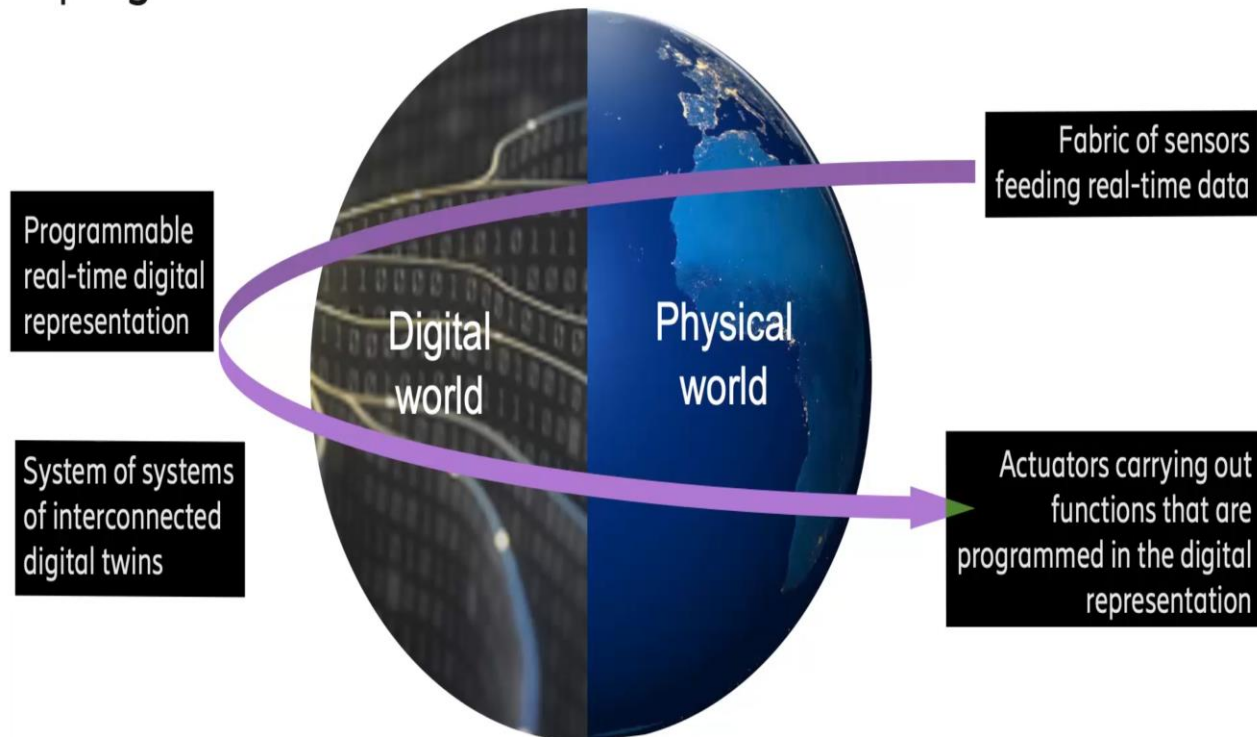
△ 16-channel 140GHz phased-array module (middle), dual-channel 140GHz RFICs (left), 128-element antenna array (right)



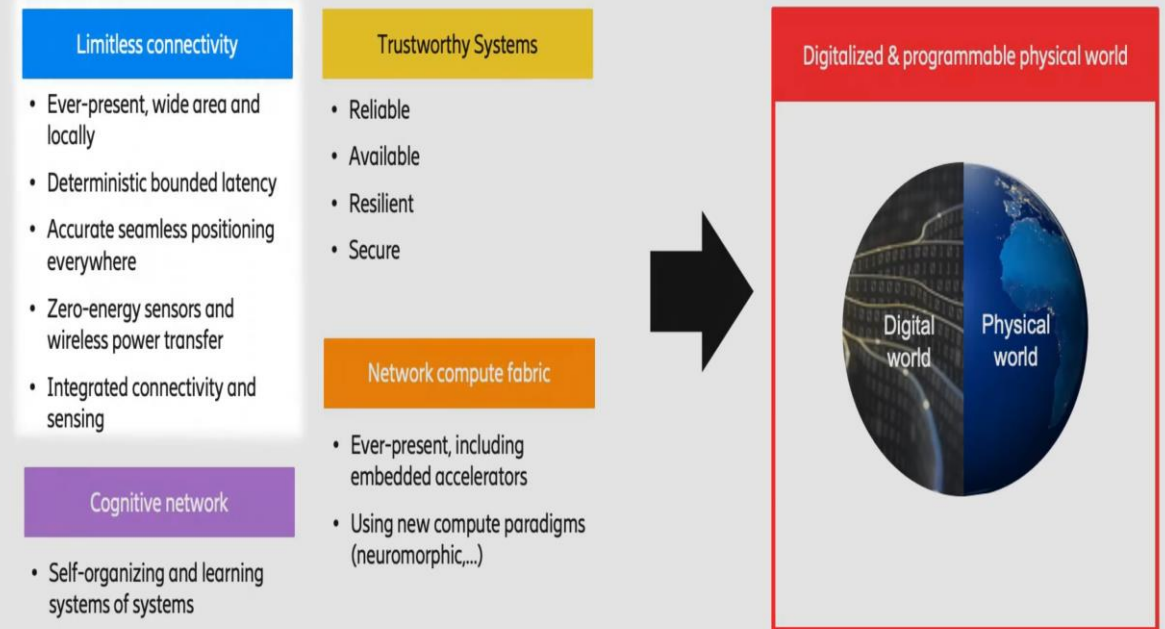


**Magnus Frodigh**  
Head of Ericsson Research

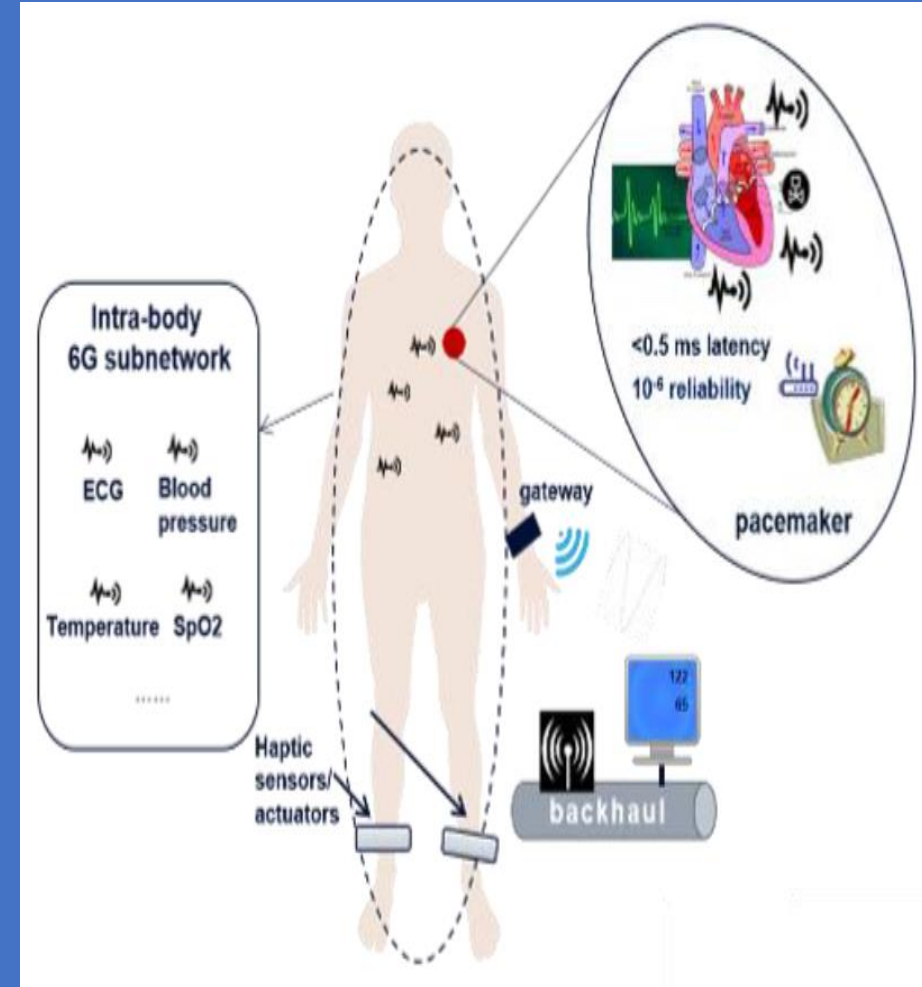
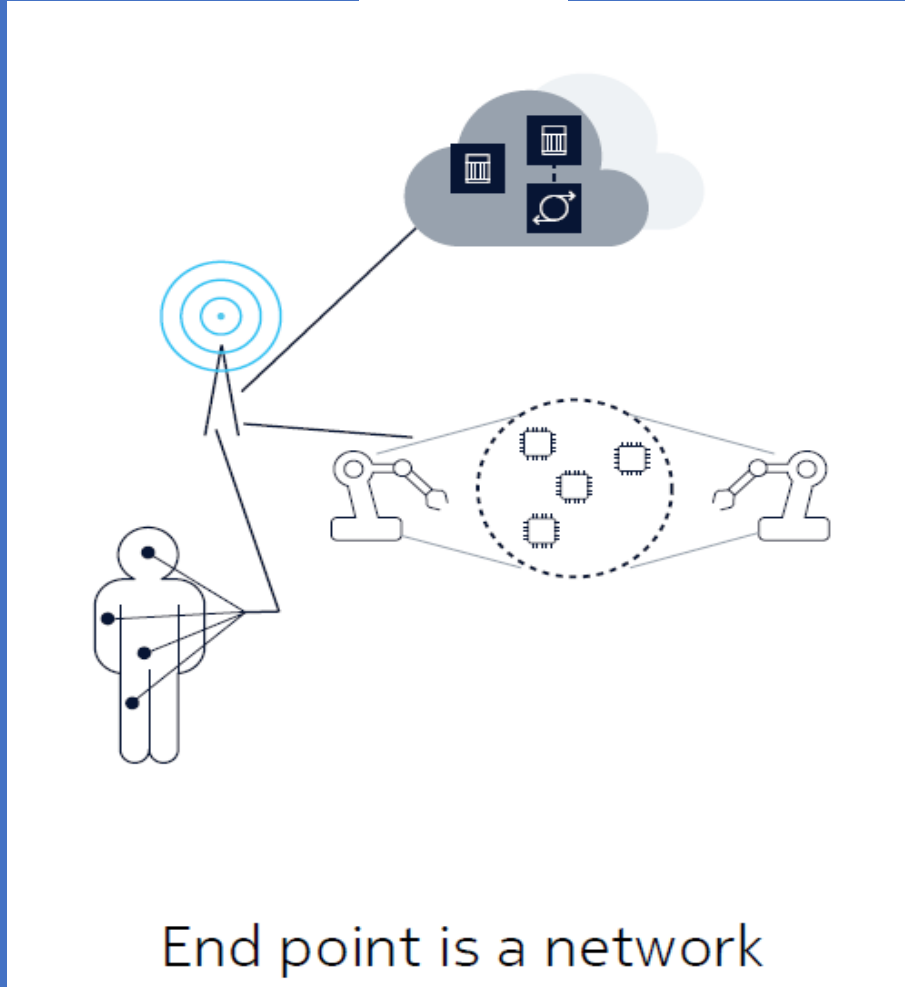
## 6G enabling a fully digitalized & programmable world



## Unique network values - Evolving 5G and 6G network capabilities



1

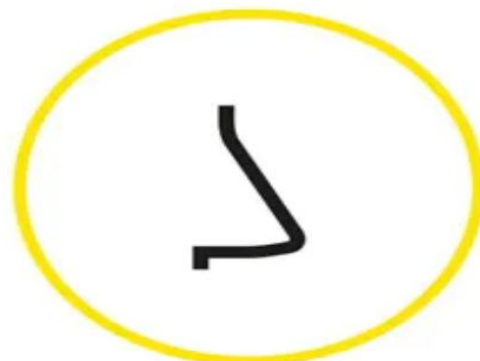




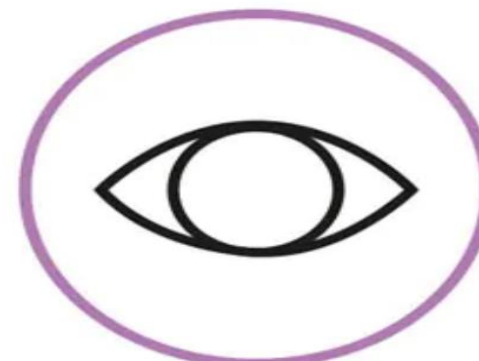
# Welcome to the internet of senses



Mind



Smell



Sight



Taste



Touch



Sound

# 10 Hot Consumer Trends 2030

Welcome to the internet of the senses.



## 01. Your brain is the user interface

Fifty-nine percent of consumers believe that we will be able to see map routes on VR glasses by simply thinking of a destination.



## 02. Sounds like me

Using a microphone, 67 percent believe they will be able to take on anyone's voice realistically enough to fool even family members.



## 03. Any flavor you want

Forty-five percent predict a device for your mouth that digitally enhances anything you eat, so that any food can taste like your favorite treat.



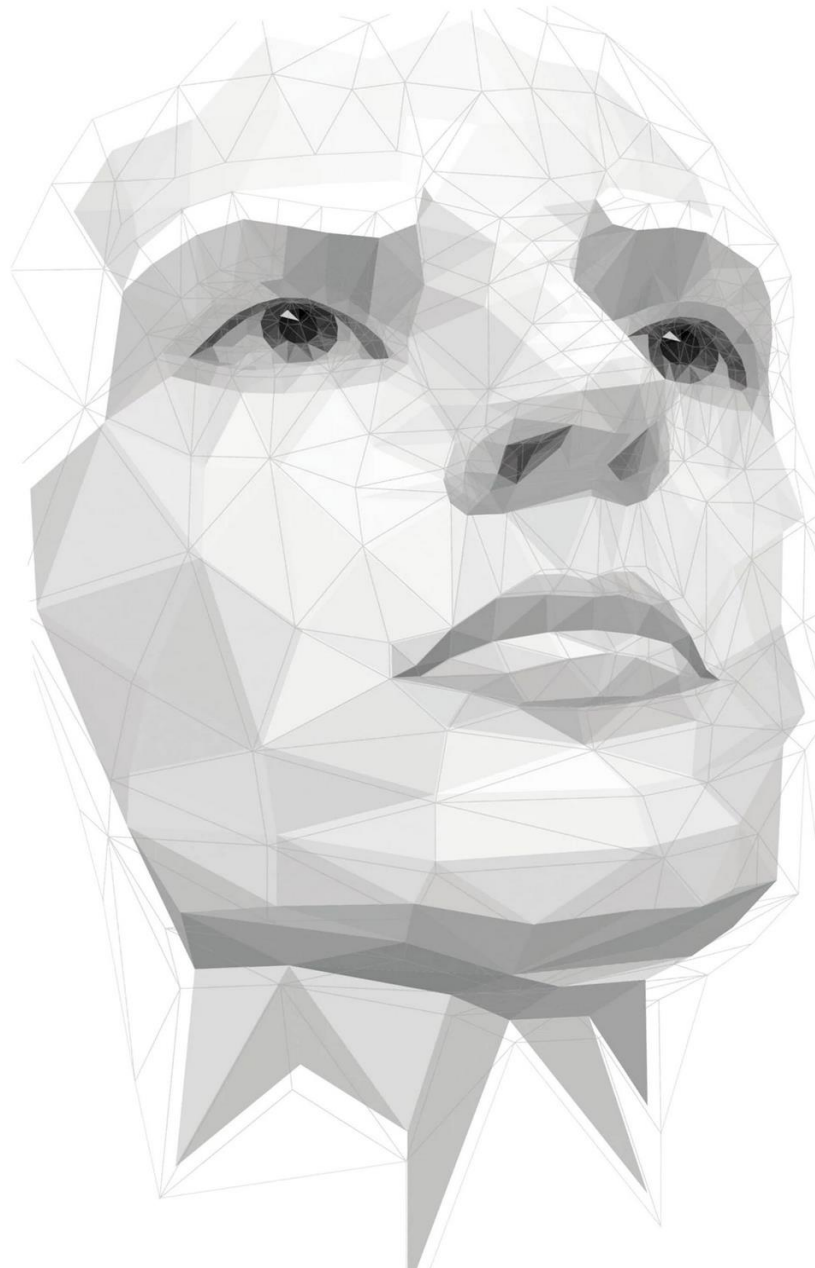
## 04. Digital aroma

Around 6 in 10 expect to be able to digitally visit forests or the countryside, including experiencing all the natural smells of those places.



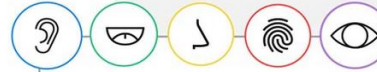
## 05. Total touch

More than 6 in 10 expect smartphones with screens that convey the shape and texture of the digital icons and buttons they're pressing.



## 06. Merged reality

VR game worlds are predicted by 7 in 10 to be indistinguishable from physical reality by 2030.



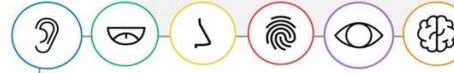
## 07. Verified as real

"Fake news" could be finished – half of respondents say news reporting services that feature extensive fact checks will be popular by 2030.



## 08. Post-privacy consumers

Half of respondents are "post-privacy consumers" – they expect privacy issues to be fully resolved so they can safely reap the benefits of a data-driven world.



## 09. Connected sustainability

Internet of senses-based services will make society more environmentally sustainable, according to 6 in 10.



## 10. Sensational services

Forty-five percent of consumers anticipate digital malls allowing them to use all five senses when shopping.

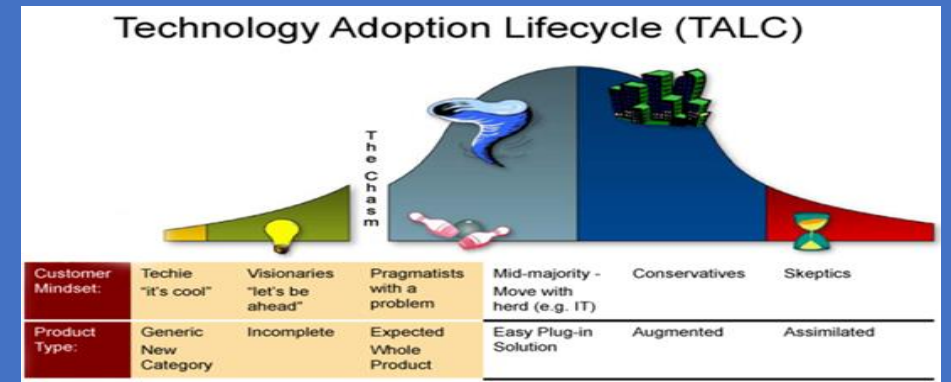
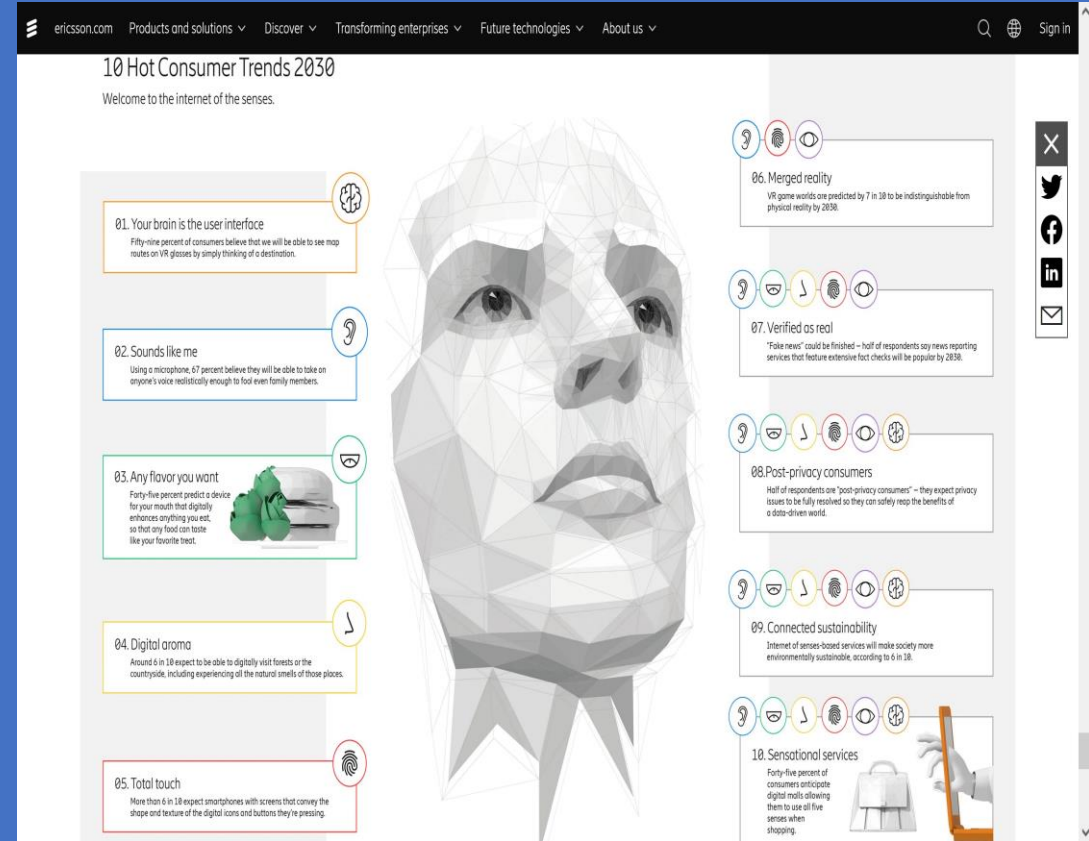


# Methodology

The Quantitative Results referred to in the Report are based on an **Online Survey of Residents** in Bangkok, Delhi, Jakarta, Johannesburg, London, Mexico City, Moscow, New York, San Francisco, São Paulo, Shanghai, Singapore, Stockholm, Sydney and Tokyo, carried out in October 2019.

The **Sample** consists of at least **500 Respondents from each city (12,590 respondents were contacted in total, out of whom 7,608 qualified), aged 15–69, who currently are either regular users of augmented reality (AR), virtual reality (VR) or virtual assistants, or who intend to use these technologies in the future.**

Correspondingly, they represent only 46 million citizens out of 248 million living in the metropolitan areas surveyed, and this, in turn, is just a small fraction of consumers globally. However, we believe their early adopter profile makes them important when exploring expectations on technology for the next decade.





# 3GPP TR 22.859 V1.0.0 (2021-03)

*Technical Report*

**3rd Generation Partnership Project;  
Technical Specification Group Services and System Aspects;  
Study on Personal Internet of Things (PIoT) networks  
(Release 18)**



A GLOBAL INITIATIVE

# ETSI TS 103 410-8 V1.1.1 (2020-07)



SmartM2M;  
Extension to SAREF;  
Part 8: eHealth/Ageing-well Domain



Figure 11: SAREF and its extensions

# 3GPP TR 22.859 V1.0.0 (2021-03)

Technical Report

3rd Generation Partnership Project;  
Technical Specification Group Services and System Aspects;  
**Study on Personal Internet of Things (PIoT) networks  
(Release 18)**

# ETSI TS 103 410-8 V1.1.1 (2020-07)



Figure 11: SAREF and its extensions

SmartM2M;  
**Extension to SAREF;  
Part 8: eHealth/Ageing-well Domain**



A GLOBAL INITIATIVE

# 3GPP TR 22.859 V1.0.0 (2021-03)

*Technical Report*

**3rd Generation Partnership Project;  
Technical Specification Group Services and System Aspects;  
Study on Personal Internet of Things (PIoT) networks  
(Release 18)**



A GLOBAL INITIATIVE

## 3.1 3GPP 5GS Study on Personal Internet of Things (PlOT) Networks - 2

- i) Wearable devices;
- ii) Home automation

For the purpose of this discussion these will be called “Personal IoT networks” (PINs). These types of networks are very different to commercial IoT device, they are usually less rugged, most highly battery constrained and lifespan of the battery typically a couple of days or weeks. User plane traffic typically stays with a constrained environment, around the body or in the home i.e. within the PIN.

PINs have been around for a long time using others standards however their take up / adoption rate has been low compared to the general smartphone UE.

- a) An example of a home automation PIN can be seen in Figure 4-1 where there are a number of devices in the home that either communicate directly with the hub or indirectly via a relay to the hub. A smartphone in the 5G system can receive notifications regarding events (e.g. door opens) from the home automation PIN.

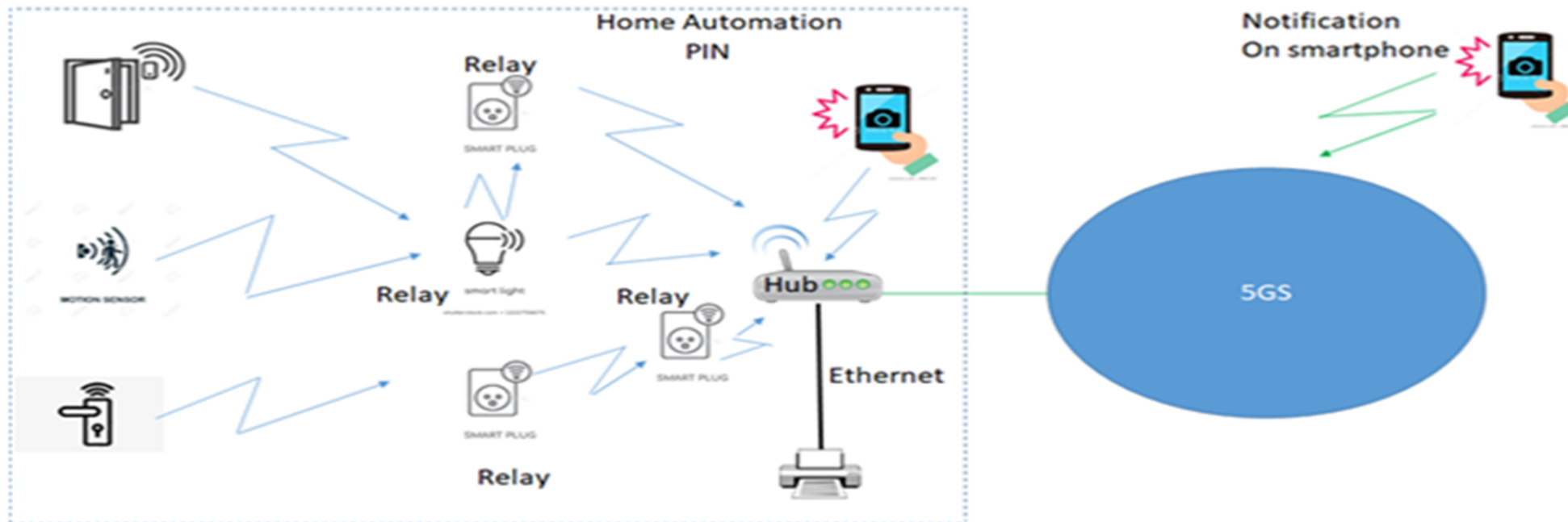
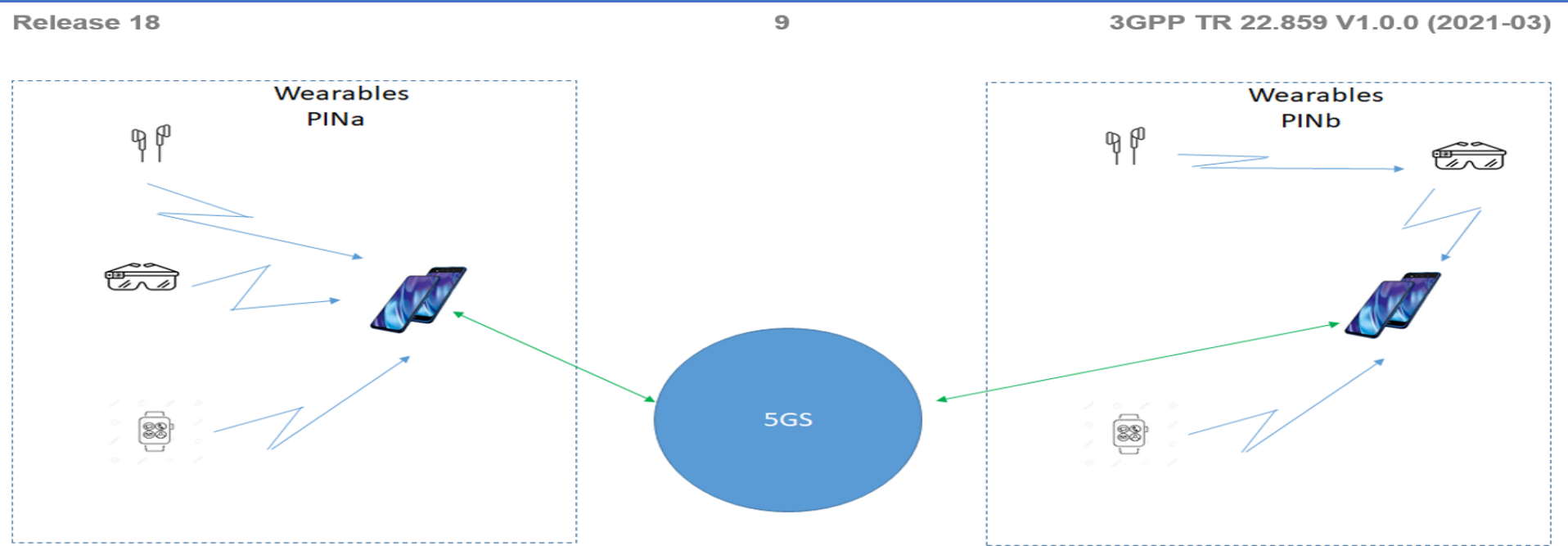


Figure 4-1: Home automation PIN

## 3.1 5GS PlOTs - Personal IoT Networks - 3



**Figure 4-2: Wearable PINs**

In summary, it is considered beneficial for 3GPP specification to address 5G system support of different use cases for PINs.

## 5 Use cases

### 5.1 Traffic Scenario: inHome

#### 5.1.1 Description

Houses have many opportunities to be automated, the traditional light bulbs, power sockets, thermostats, sprinkler systems, leak detection and the new smart appliances such as ovens, washing machines, faucets etc. can communicate with each other via a Personal IoT Network (PIN). These devices, to be known as PIN Elements, can have the following characteristics:

- i) some have continuous power and others don't;

## 3.1 5GS PloTs - Personal IoT Networks - 4

As more and more Personal IoT Networks are deployed there starts to become ubiquitous coverage provided by these networks. This allows for new service offerings to be offered to subscribers. One such offering is where PIN network owners, via user and or service provider authorisation can allow nomadic (guest) PIN Elements to use their PIN networks to reach a specific service in the cloud or in their own personal PIN. A small amount of bandwidth can be dedicated to this. One such offering can be found here [17].

In addition, the PIN network can contain multitude of devices, some using PIN direct device connection's that use operator managed spectrum and some that do not. Figure 5.1A.1-1 shows a possible guest PIN Element obtaining access via a PIN2. The user plane data is sent transparently (via a user plane pipe) from the guest PIN2 to a server in the cloud and then server communicates the user plane data to the smartphone (PIN Element) in PIN1.

NOTE 1: The contents of the user plane is outside the scope of 3GPP.

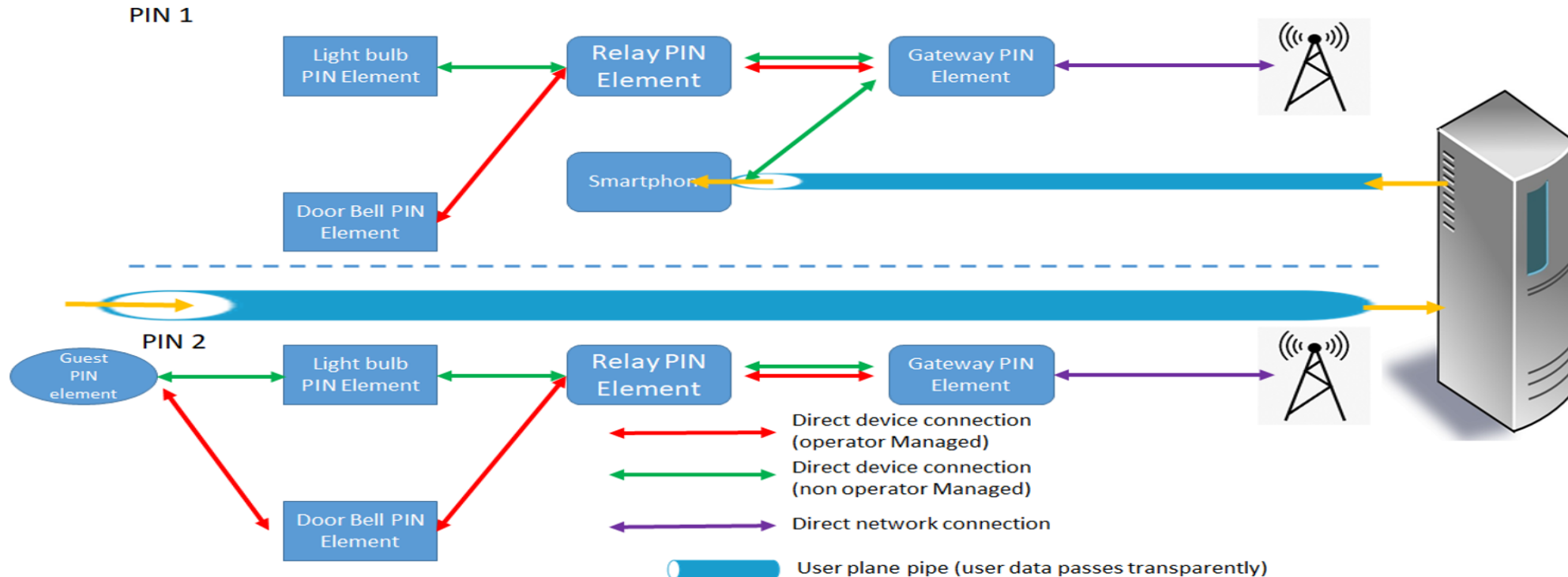


Figure 5.1A.1-1. Guest PIN Element accessing a PIN

## 3.1 5GS Plots - Personal IoT Networks - 5

### 5.5 Use case: UE accessing Services provided by PIN Devices behind 5G enabled gateway(s)

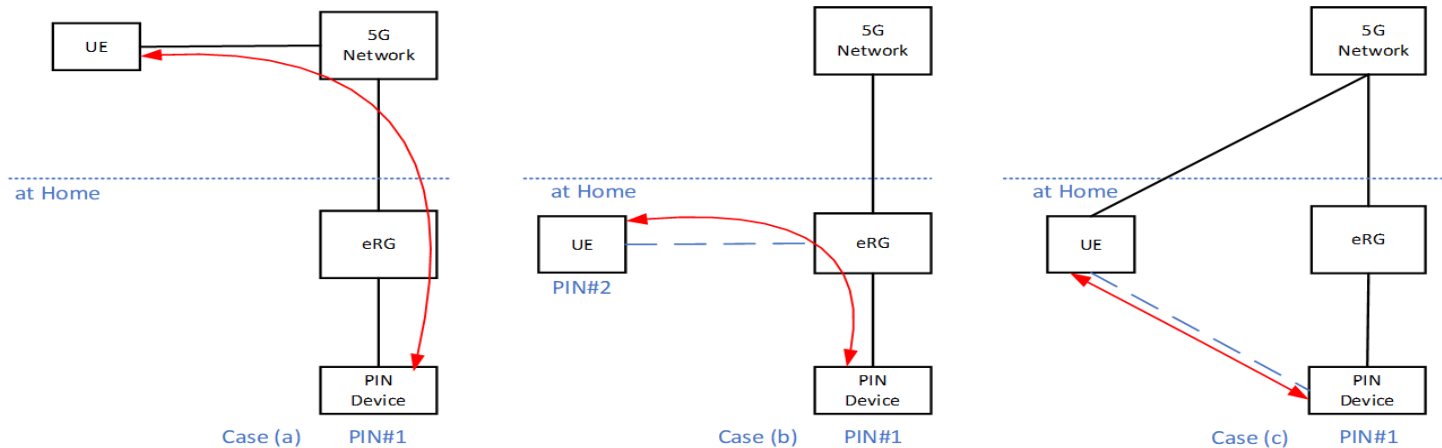
#### 5.5.1 Description

There are more and more PIN Devices, e.g. media server, printer, smart thermostat/sprinkler/blinds, NAS server, etc., that can provide services for users at home or out of home. These PIN devices are usually behind a wireless gateway. In recent years, there are some security risks found in such settings due to port forwarding and unsecure connectivity provided by the wireless gateway for in home devices.

When considering the gateway with 5G capability for accessing 5G services, e.g. UE or evolved Residential Gateway (eRG), it is important to enable the support of the secure connectivity for allowing authorized users from anywhere in the world to access authorized services provided by these PIN Devices in terms of user authentication and authorization.

**Editor's Note:** evolved residential gateway (eRG) is defined in TR 22.858 [6].

Figure 5.5.1-1 shows the scenarios of the 5G network enabling connectivity service support for the UE using 3GPP indirect (case a) or direct (case b) communication or non-3GPP access (case c) to access services provided by PIN Devices. Each PIN Device may provide one or more services. For example, the PIN Device is a media server, smart TV, smart video doorbell, etc., which provide one media service. For another example, the PIN Device is a NAS server which can provide multiple services, e.g. media service, web server service, live security cams services, etc.



**Figure 5.5.1-1: 5G network support for a User/UE accessing services provided by in Home Devices**

## Residential Gateway (RG)

The Residential Gateway (RG) is a Device providing, e.g.

- Voice,
- Data,
- Broadcast Video,
- Video on Demand,

to other Devices in Customer Premises.



# 5G System Architecture Rel. 16 Access Traffic Steering, Switch and Splitting (ATSSS)

The ATSSS feature enables a **Multi-Access (MA) PDU Connectivity Service**, which can exchange PDUs between the UE and a Data Network (DN) by simultaneously using one (1) 3GPP Access Network and one (1) non-3GPP Access Network and two (2) independent N3/N9 tunnels between the PSA and RAN/AN.

The Multi-Access PDU Connectivity Service is realized by establishing a Multi-Access PDU (MA PDU) Session, i. e. a **PDU Session that may have User-Plane (UP) Rsource on two(2) Access Networks (ANs)**.

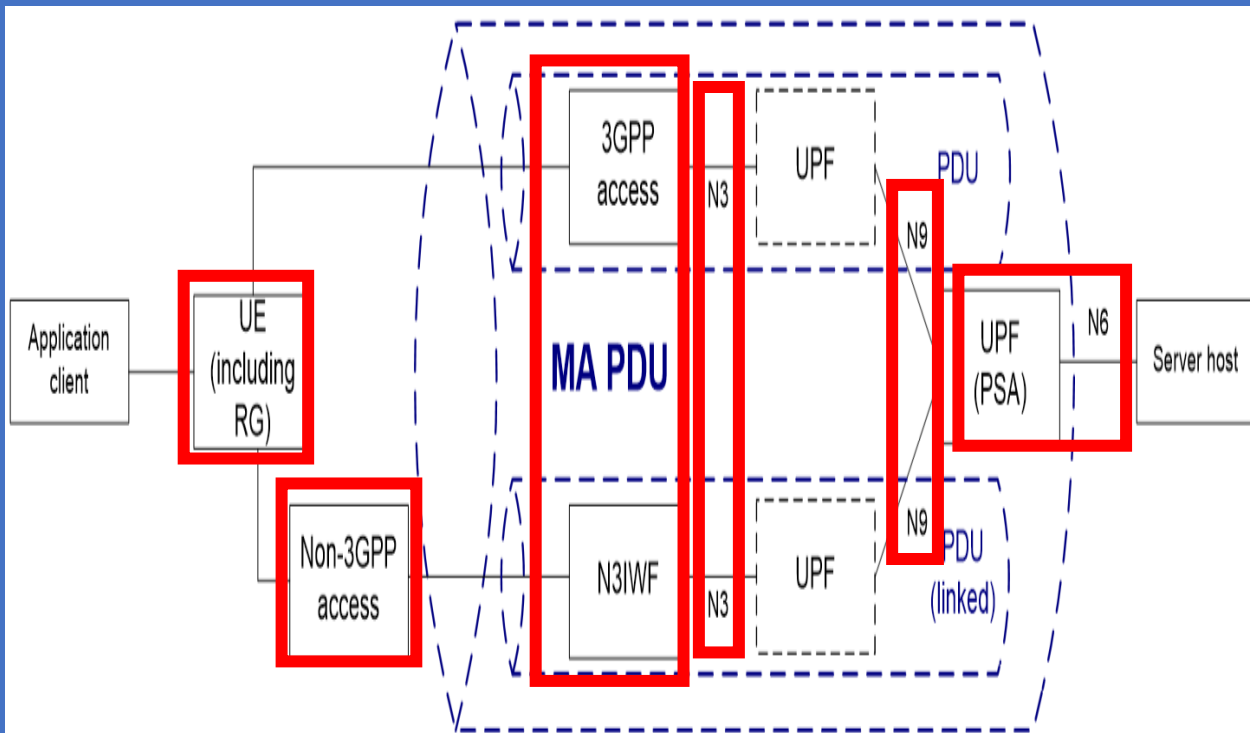


Figure 1: MA PDU session

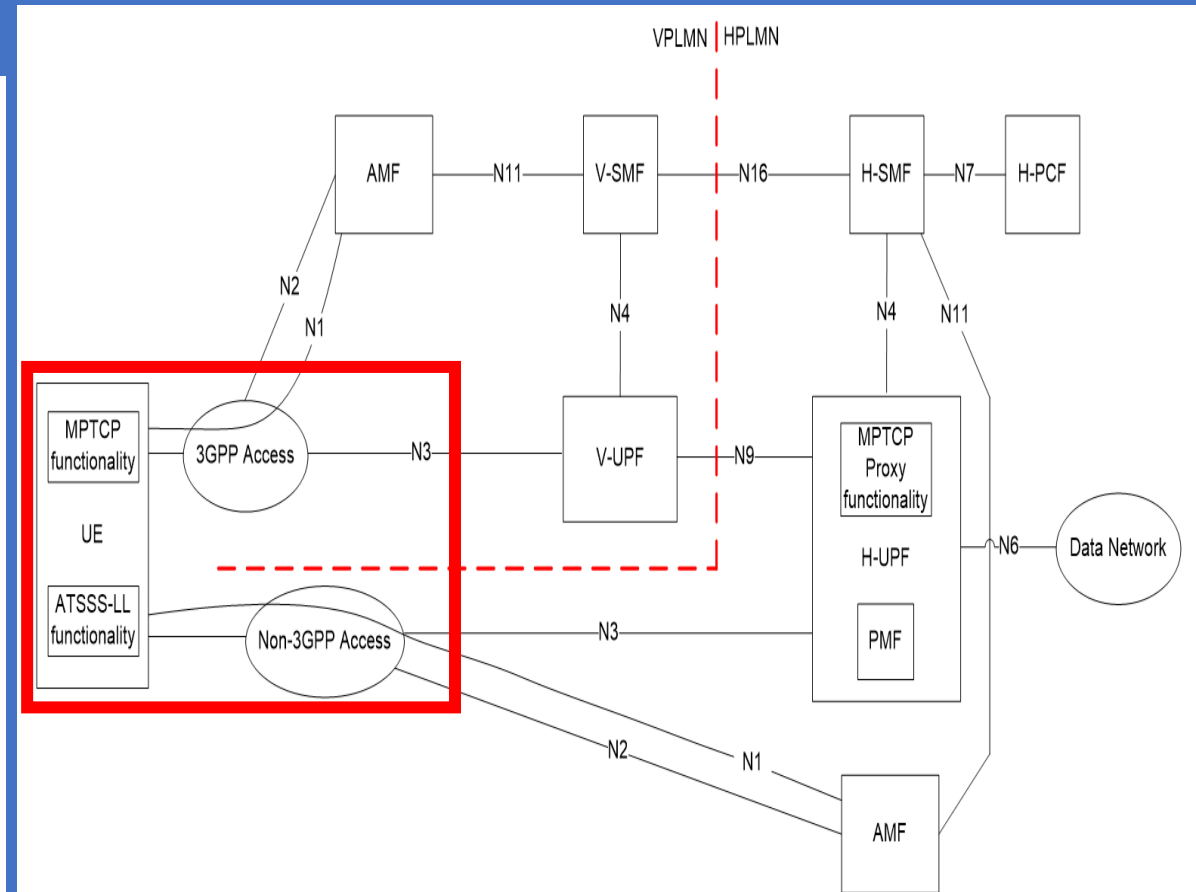


Figure 4.2.10-3: Roaming with Home-routed architecture for ATSSS support (UE registered to different PLMNs)

## PDU Session Attributes

Additionally, if the UE supports ATSSS and wants to activate a MA PDU Session, the UE shall provide Request Type as "MA PDU Request" and shall indicate the supported ATSSS capabilities (see clause 5.32 for details).

**Table 5.6.1-1: Attributes of a PDU Session**

PDU Session attribute	May be modified later during the lifetime of the PDU Session	Notes
S-NSSAI of the HPLMN	No	(Note 1) (Note 2)
S-NSSAI of the Serving PLMN	Yes	(Note 1) (Note 2) (Note 4)
DNN (Data Network Name)	No	(Note 1) (Note 2)
PDU Session Type	No	(Note 1)
SSC mode	No	(Note 2) The semantics of Service and Session Continuity mode is defined in clause 5.6.9.2
PDU Session Id	No	
User Plane Security Enforcement information	No	(Note 3)
Multi-access PDU Connectivity Service	No	Indicates if the PDU Session provides multi-access PDU Connectivity Service or not.
NOTE 1: If it is not provided by the UE, the network determines the parameter based on default information received in user subscription. Subscription to different DNN(s) and S-NSSAI(s) may correspond to different default SSC modes and different default PDU Session Types		
NOTE 2: S-NSSAI(s) and DNN are used by AMF to select the SMF(s) to handle a new session. Refer to clause 6.3.2.		
NOTE 3: User Plane Security Enforcement information is defined in clause 5.10.3.		
NOTE 4: The S-NSSAI value of the Serving PLMN associated to a PDU Session can change whenever the UE moves to a different PLMN, while keeping that PDU Session.		

Subscription Information may include a wildcard DNN per subscribed S-NSSAI: when a wildcard DNN is associated with a subscribed S-NSSAI, the subscription allows, for this S-NSSAI, the UE to establish a PDU Session using any DNN value.

# ETSI TS 103 410-8 V1.1.1 (2020-07)



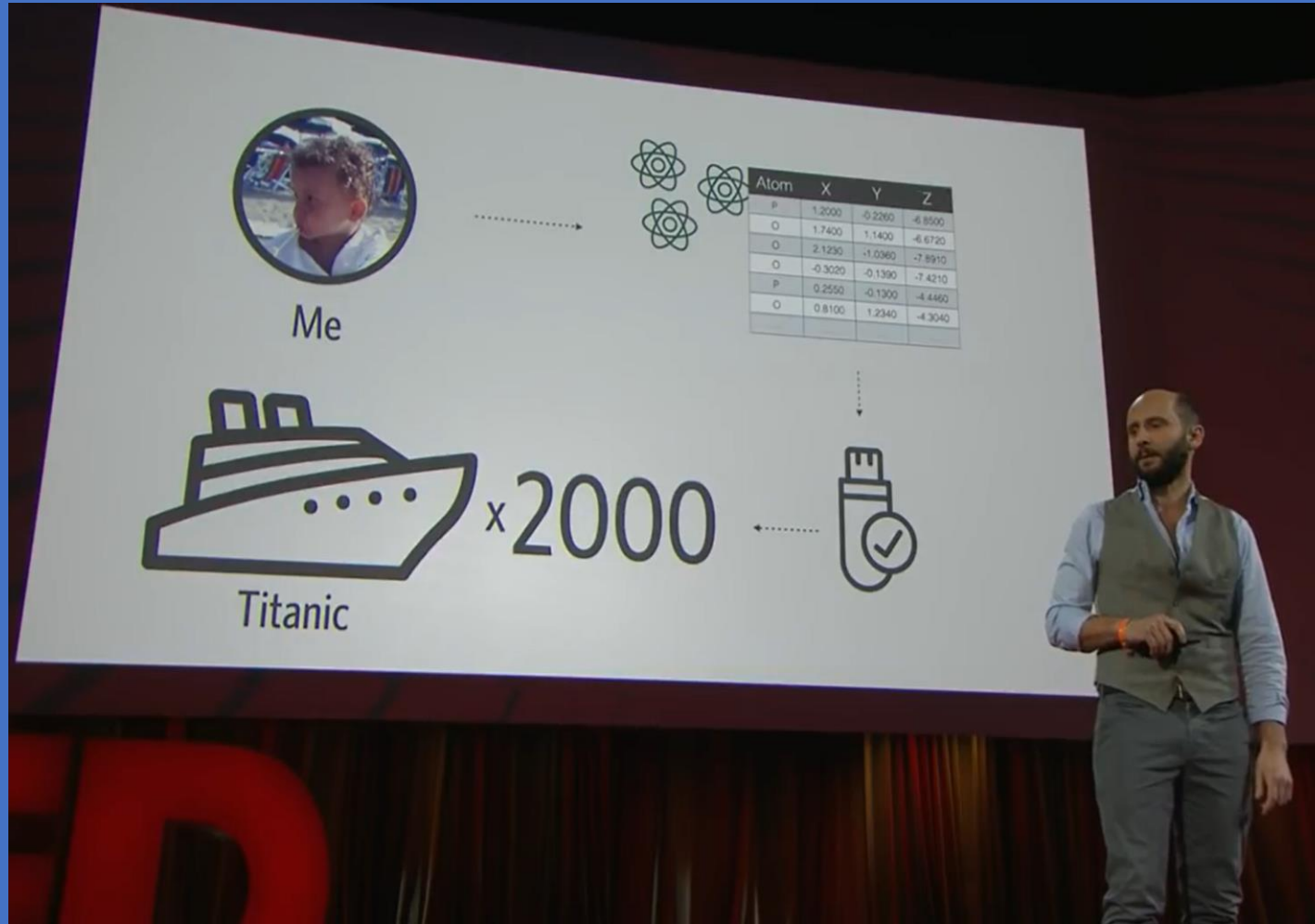
Figure 11: SAREF and its extensions

## SmartM2M; Extension to SAREF; Part 8: eHealth/Ageing-well Domain

# Genomics and Epigenetics

How to read the Genome and build a Human Being by Riccardo Sabatini

<https://www.youtube.com/watch?v=s6rJLXq1Re0>



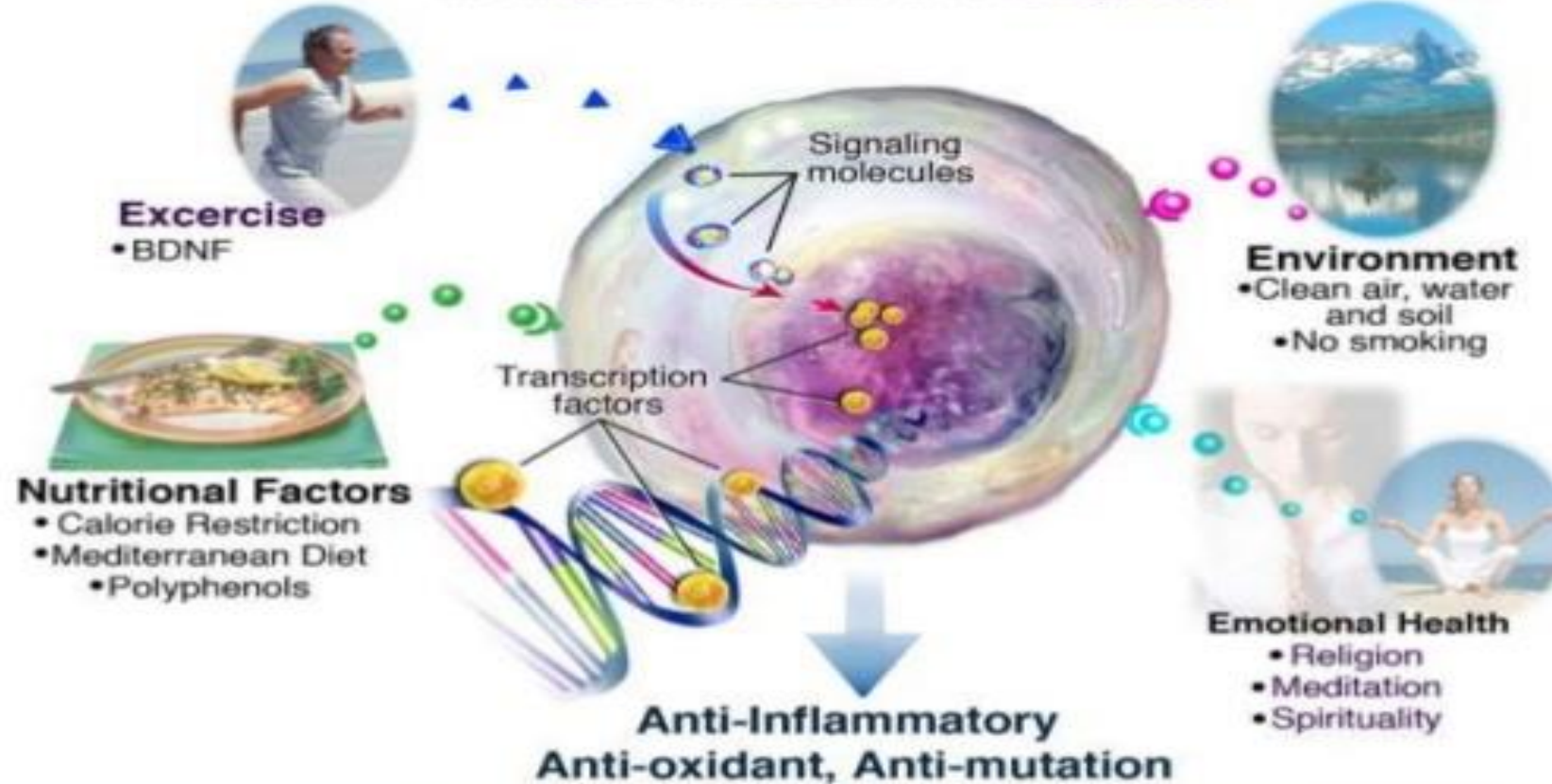
ETSI TS 103 410-8 V1.1.1 (2020-07)

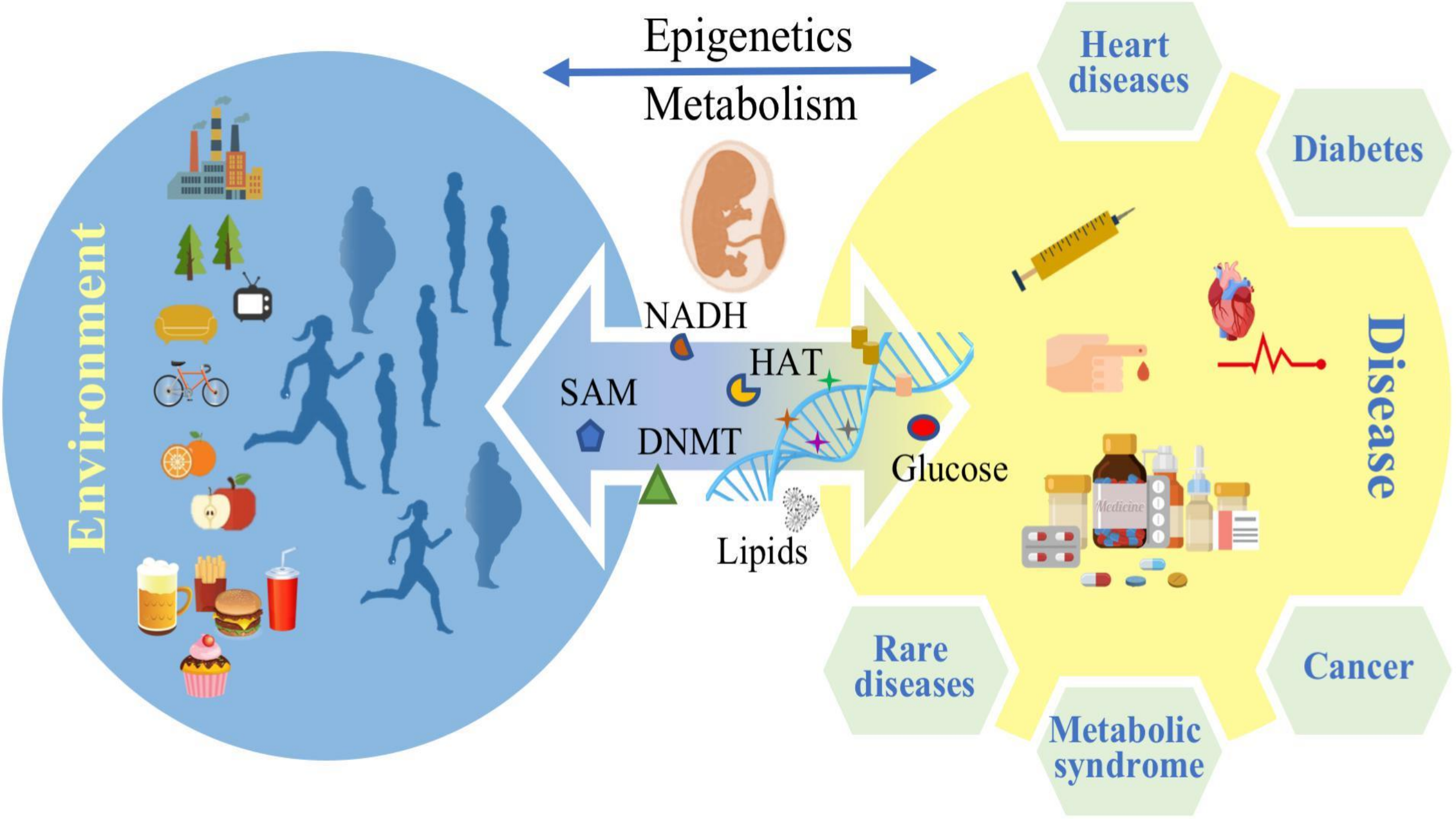


SmartM2M;  
Extension to SAREF;  
Part 8: eHealth/Ageing-well Domain

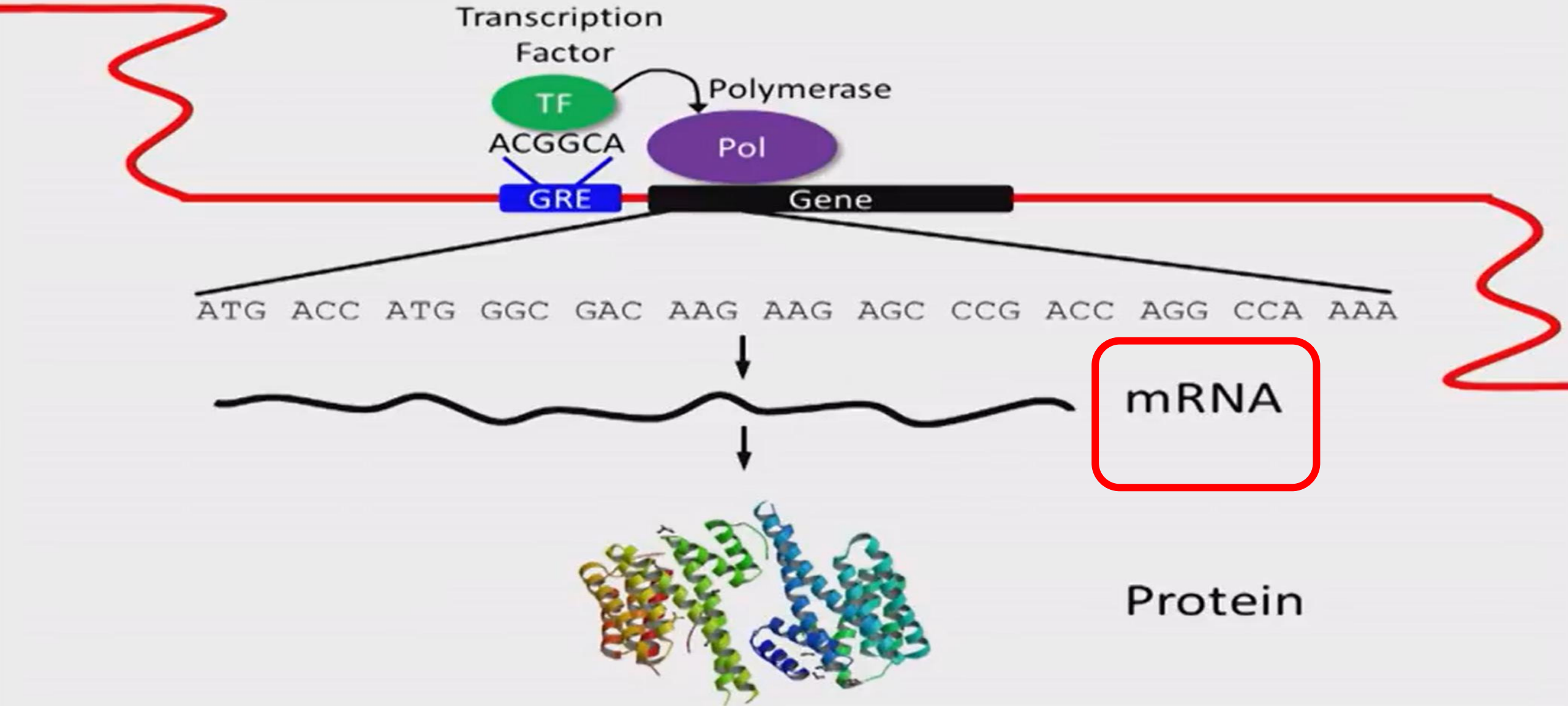
# Epigenetics

## Epigenetics and Gene Activation for Improved Health and Longevity



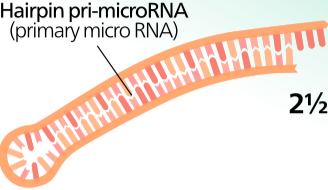


# Regulating gene expression



nucleus

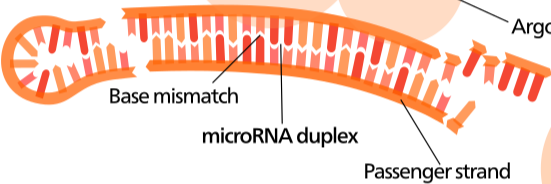
1 A protein called exportin-5 transports a hairpin primary microRNA (pri-miRNA) out of the nucleus.



Exportin-5

2½ Meanwhile, one of the strands joins a group of proteins, forming an microRNA-protein complex. The other strand, known as a passenger strand is usually discarded. How this all happens is still not very well understood.

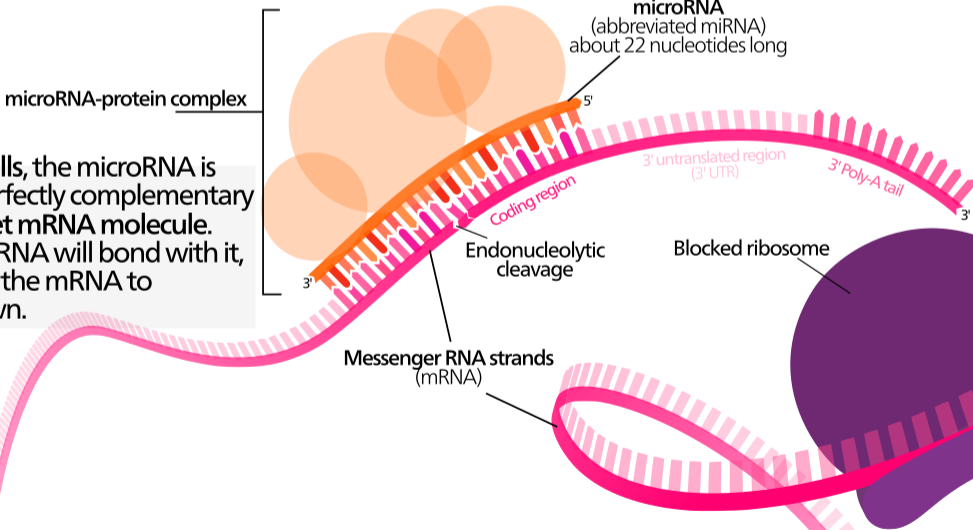
2 An enzyme called dicer (not shown) trims the pri-microRNA and removes the hairpin loop, leaving a double stranded microRNA duplex molecule.



Argonaute proteins

4 In animal cells, the microRNA nucleotides typically don't pair up with the mRNA nucleotides as well. Their base pairing often follows a pattern though.

3 In plant cells, the microRNA is usually perfectly complementary to its target mRNA molecule. The microRNA will bond with it, and cause the mRNA to break down.



Base mismatches

microRNA

Nucleotide 1

Has an A across from it

Deadenylation

3' Poly-A tail

Seed Region (Nucleotides 2-8)  
Perfect base pairing

Nucleotide 9  
Has an A or U across from it

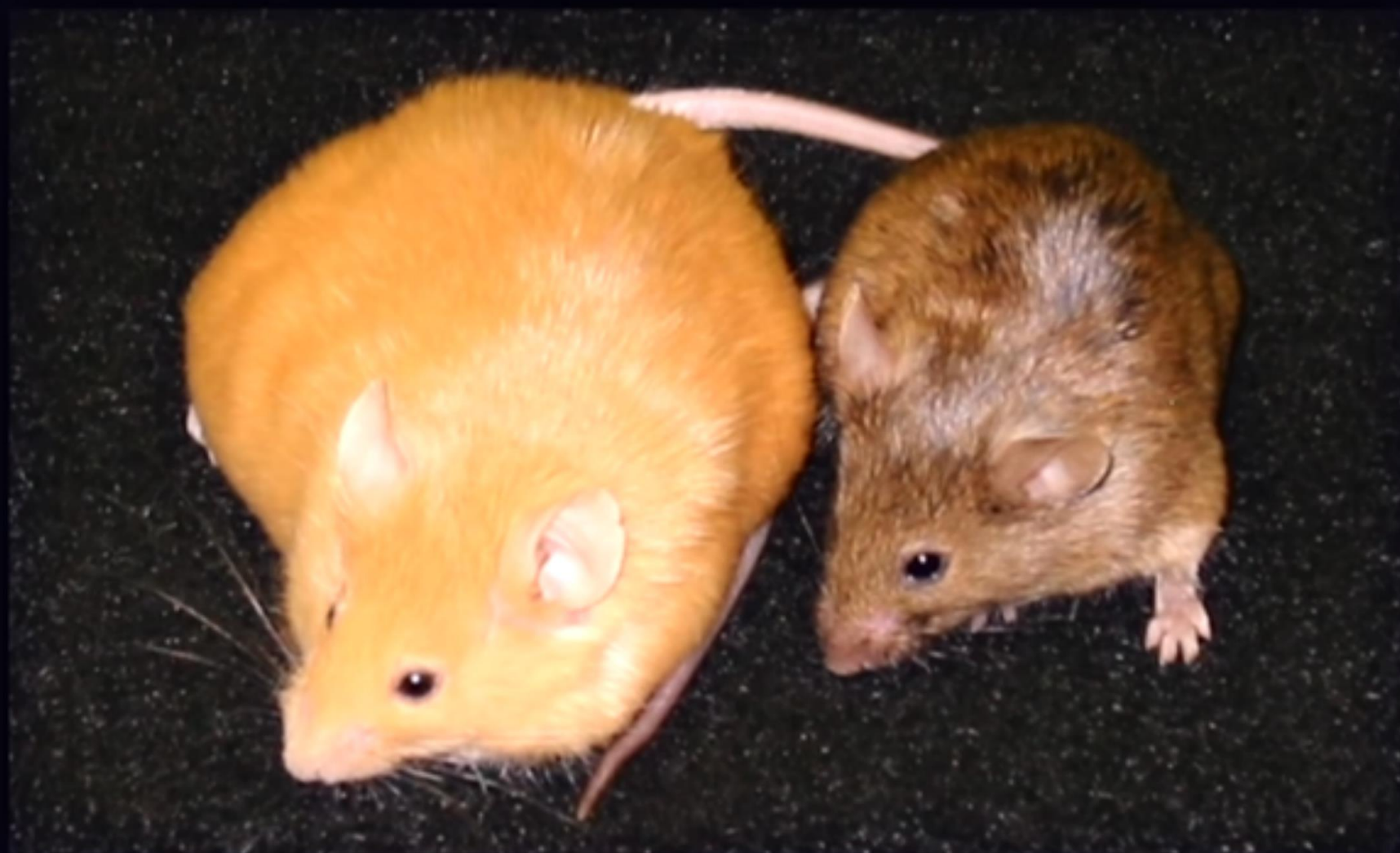
Nucleotides 13-16  
Good base pairing

5 The microRNA-protein complex's presence blocks translation as well as speeding up deadenylation (breakdown of the Poly-A tail), which causes the mRNA to be degraded sooner and translated less.

# the formation and function of micro RNAs



**SAME GENOTYPE, DIFFERENT EPIGENOTYPE**



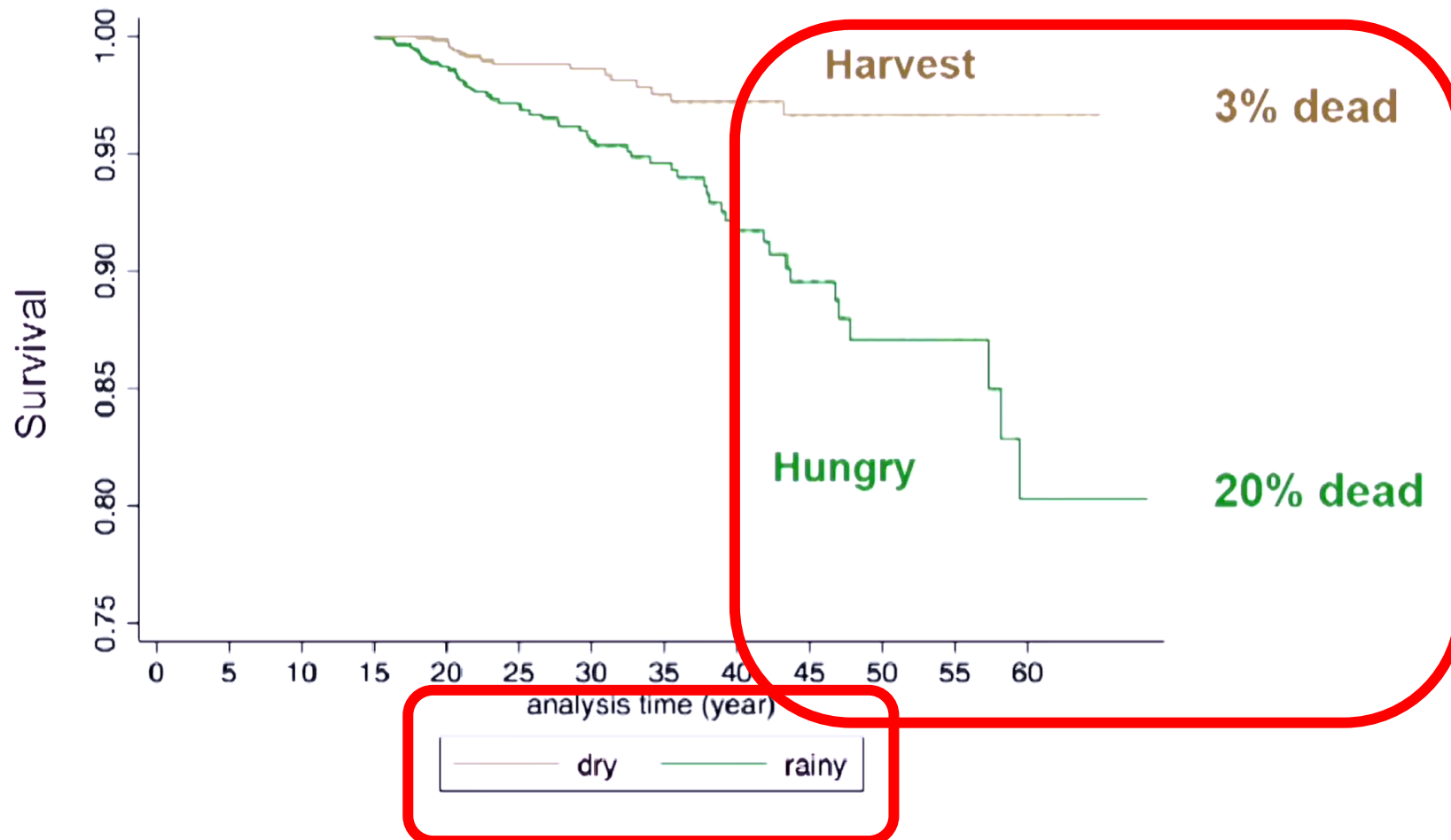
# **SEASONALITY IN GAMBIA**

**An 'experiment of nature'**





# SEASON OF BIRTH AFFECTS YOUNG ADULT MORTALITY



Majority of deaths were from infection-related causes

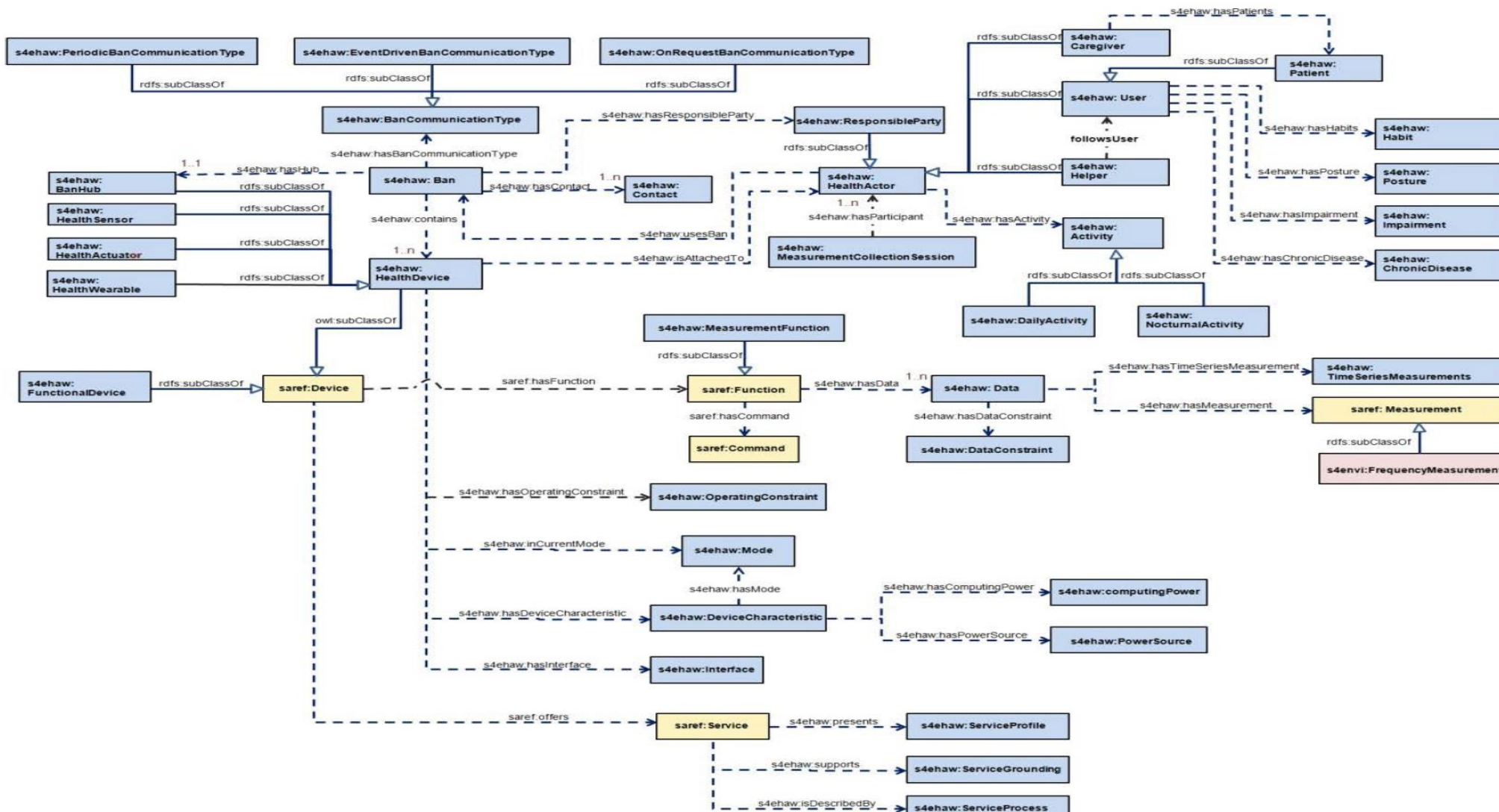
# ETSI TS 103 410-8 V1.1.1 (2020-07)



**SmartM2M;  
Extension to SAREF;  
Part 8: eHealth/Ageing-well Domain**



Figure 11: SAREF and its extensions



**Figure 1: High level view of the envisioned semantic model for SAREF4EHAW ontology**

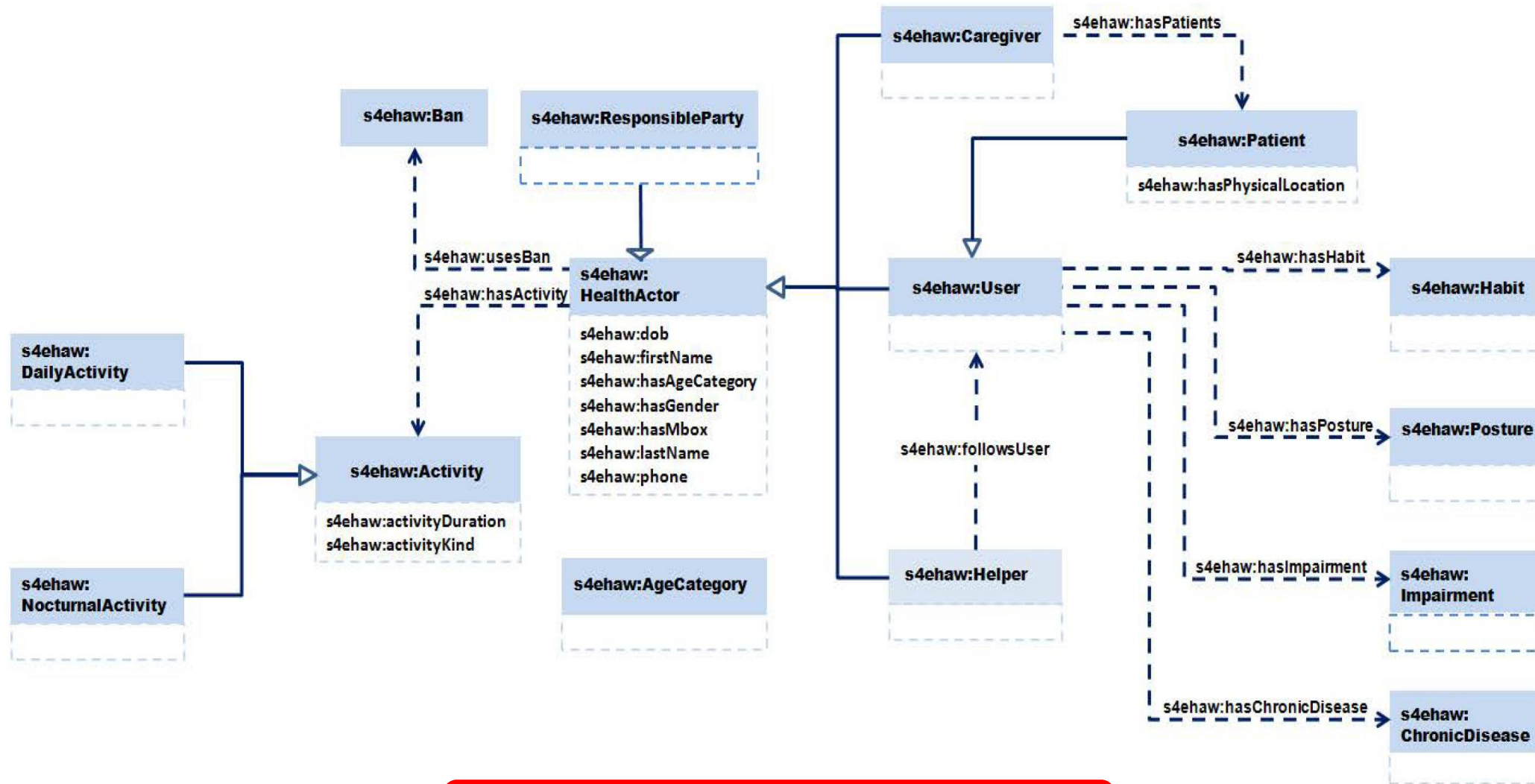


Figure 2: Detailed view of SAREF4EHAW HealthActor module



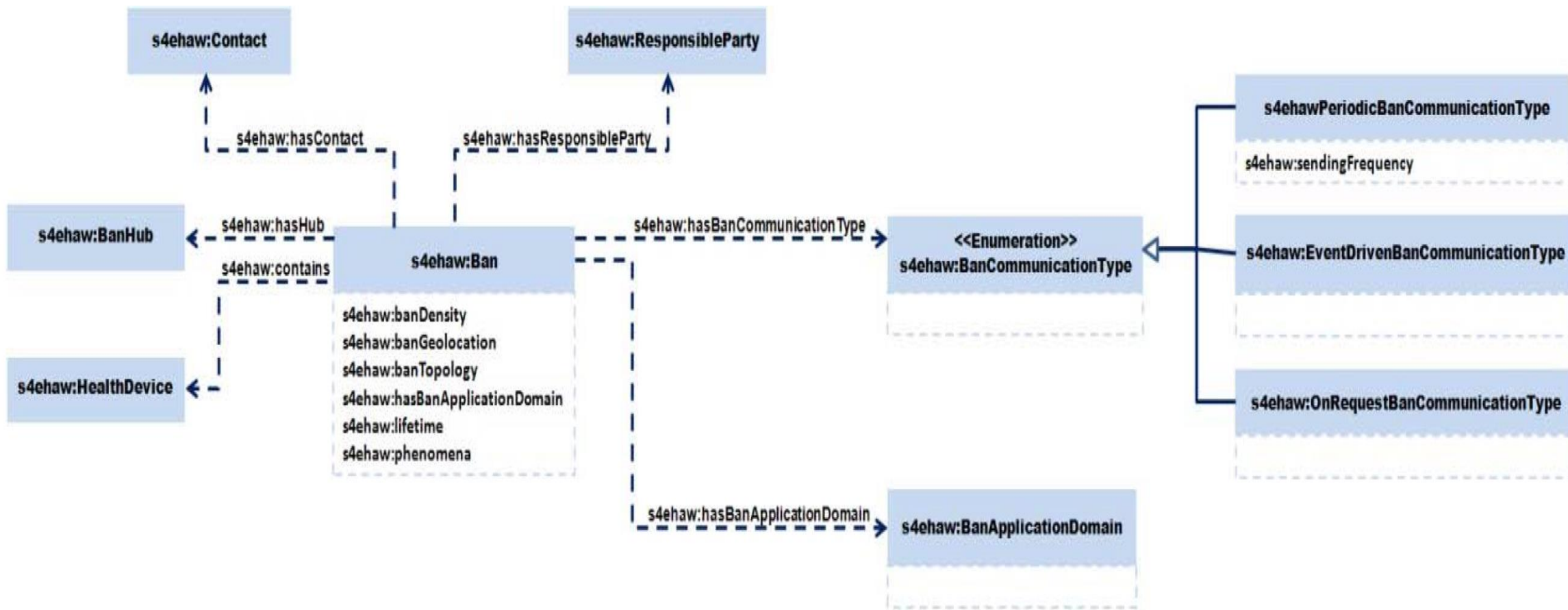
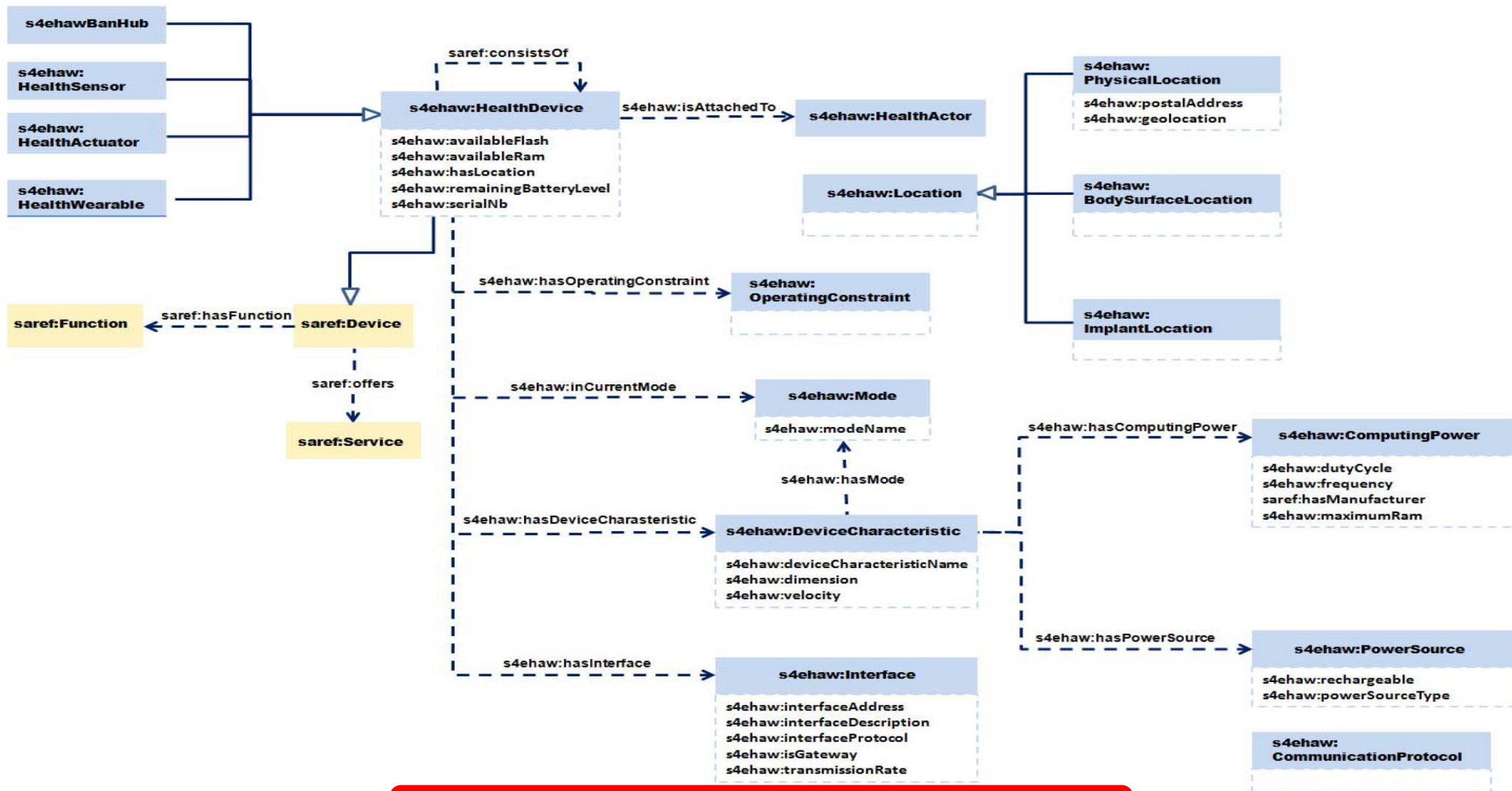
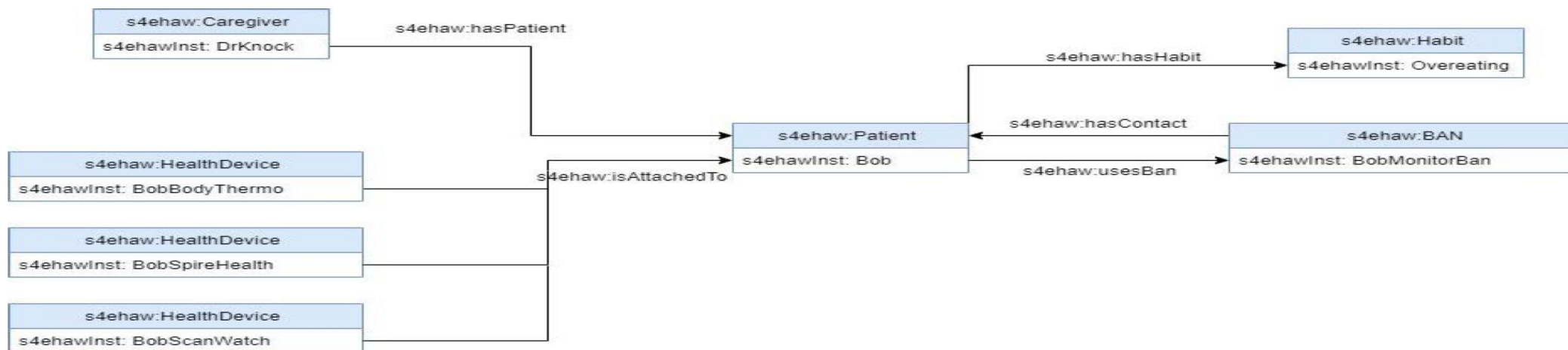


Figure 3: Detailed view of SAREF4EHAW Ban module

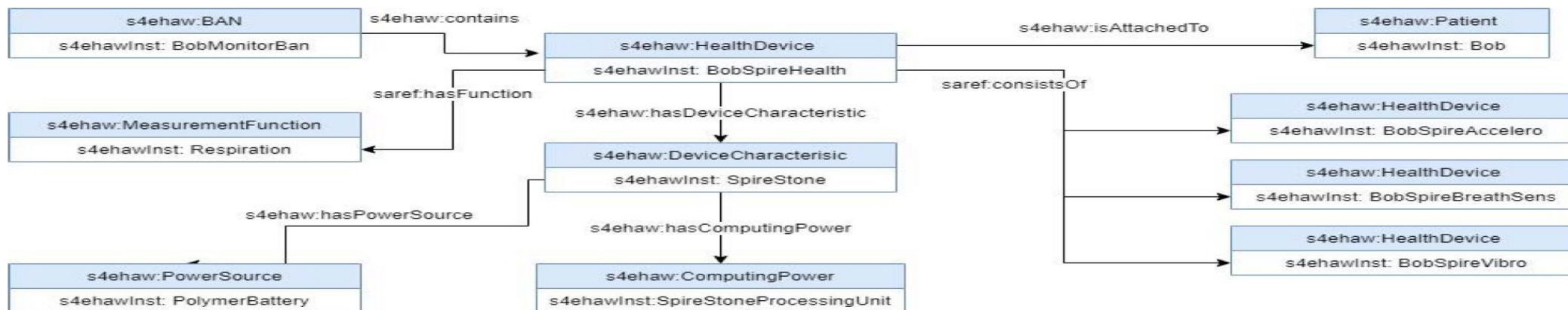


**Figure 4: Detailed view of SAREF4EHAW HealthDevice module**



**Figure 7: Patient Bob individuals**

Figure 8 depicts the SpireStone wearable device (a `s4ehaw:HealthDevice`) of Bob (a `s4ehaw:Patient`), as described using SAREF4EHAW extension.

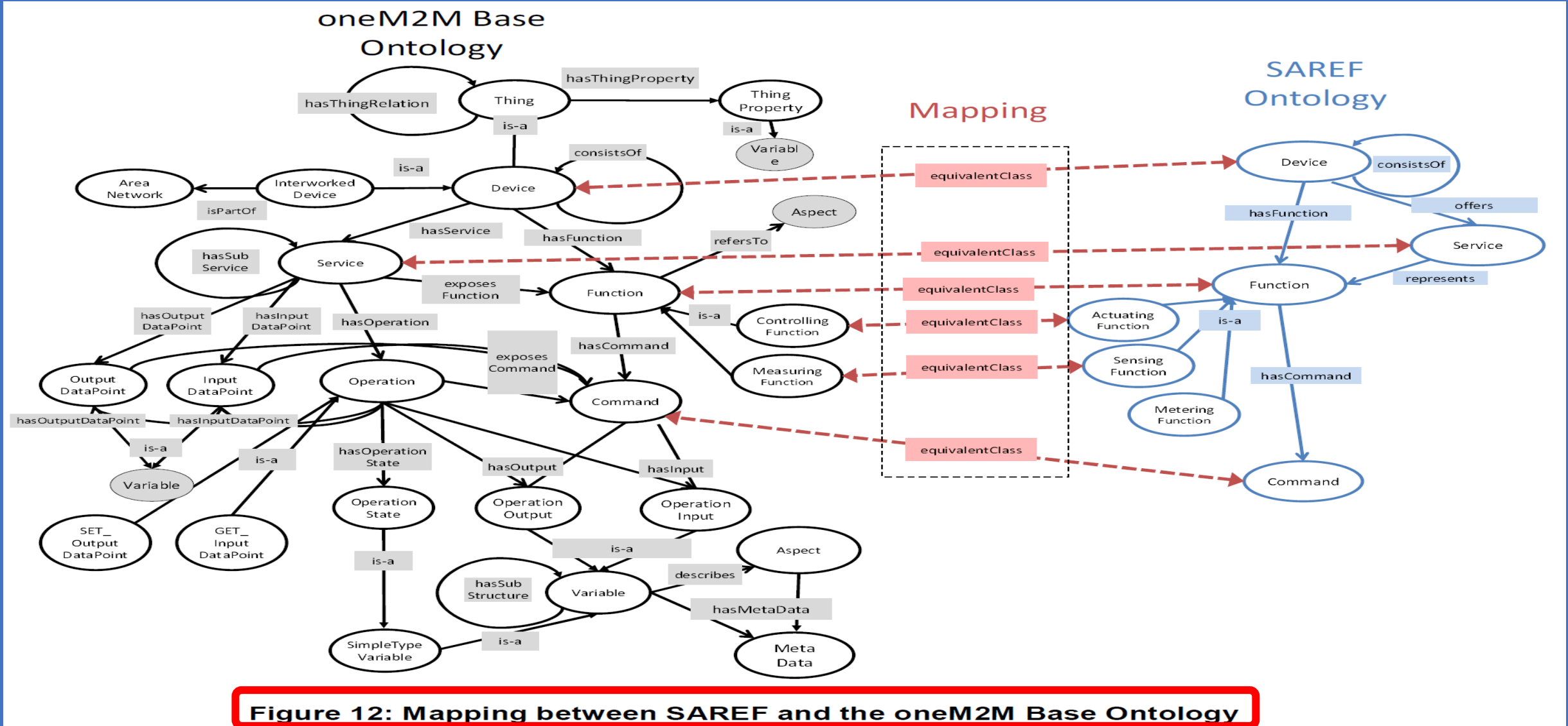


**Figure 8: BobSpireStone HealthDevice individuals**

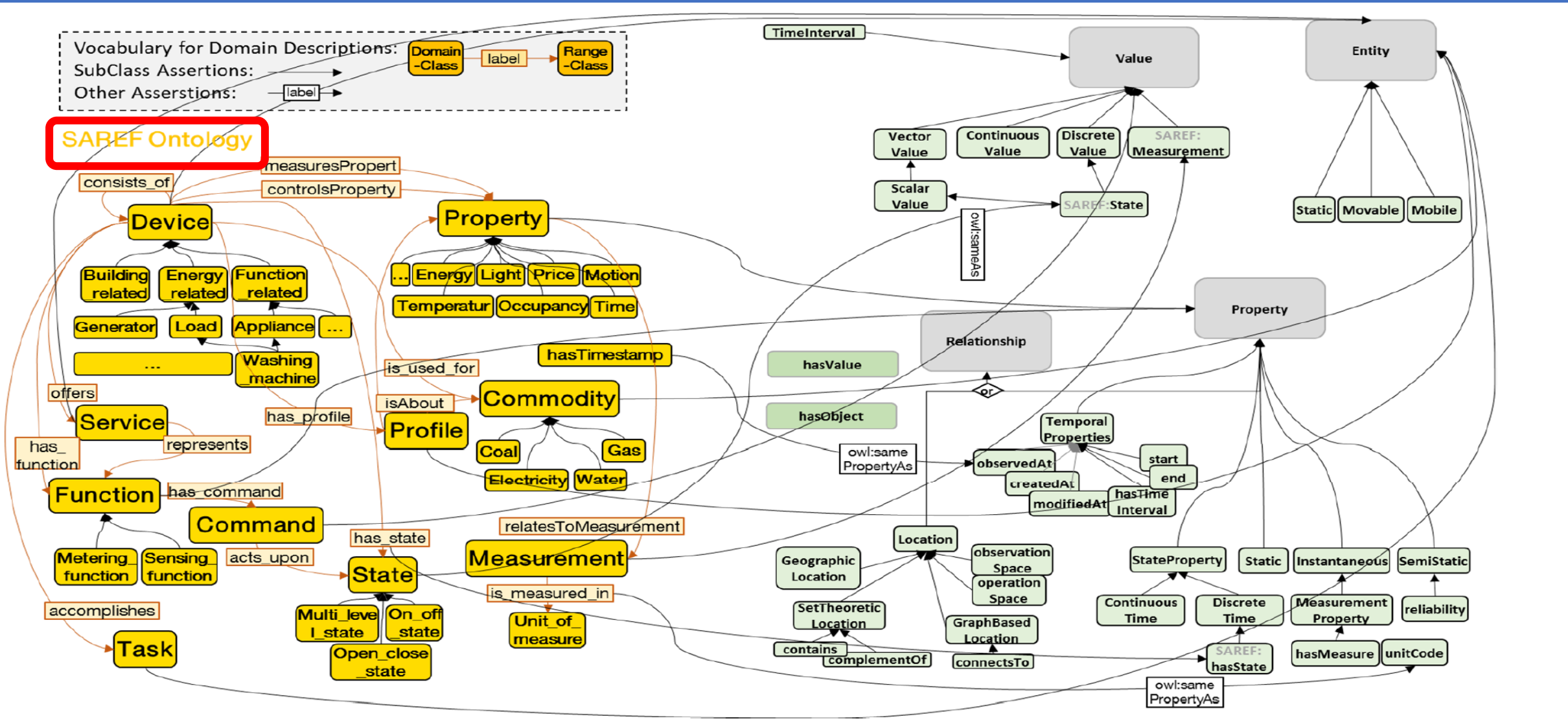
# Annex 4 - 3GPP 5G SCEF/SCS for IoT Platform integrated with IoT SL across 10 UCs - 3

## 5.2 Mapping between SAREF and oneM2M Base Ontology

Figure 12 shows the mapping between SAREF and the oneM2M Base Ontology.



# Mapping NGSI - LD cross domain Ontology to SAREF



**Figure B.4: Mapping NGSI-LD to SAREF**

## B.1 Mapping to oneM2M

oneM2M is a partnership project for IoT (originally defined as "machine to machine communication" in the Telecom world). OneM2M provides an OWL ontology that can be partially mapped to the ISG CIM cross-domain ontology, as illustrated in Figure B.1.

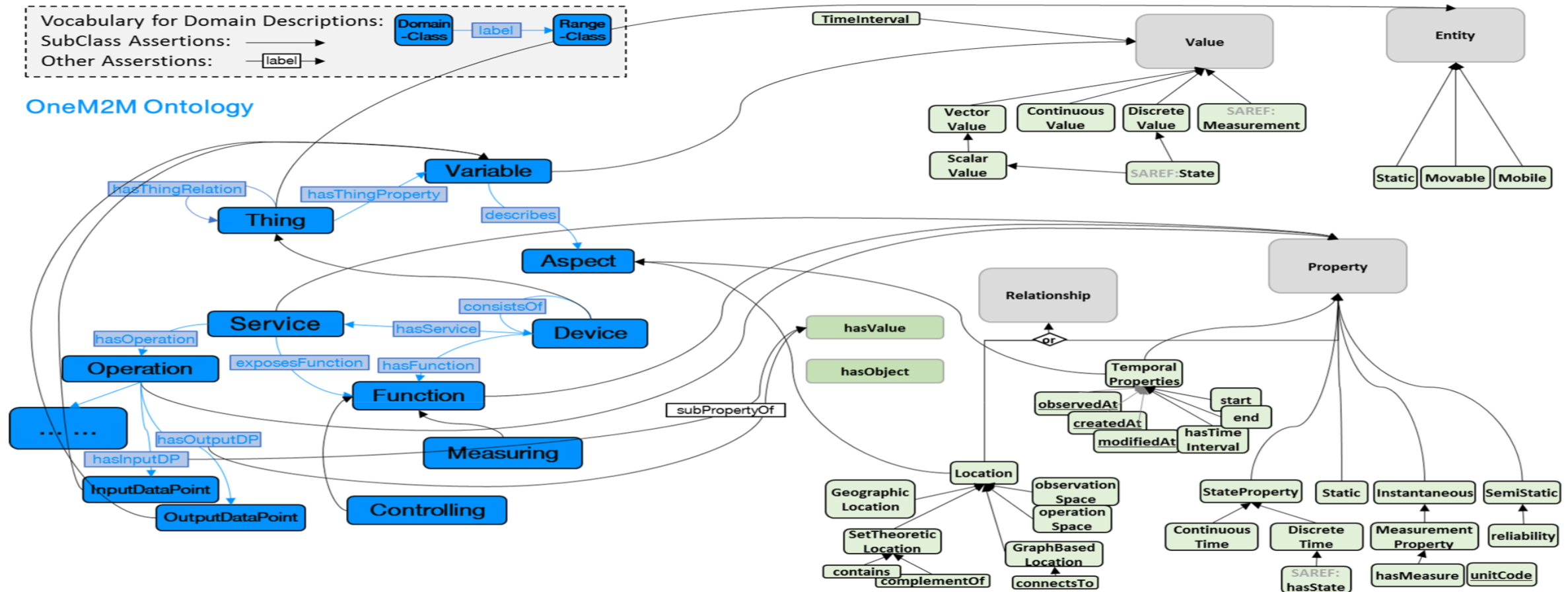


Fig. B. 1: Mapping NGSI - LD Meta - model and Cross-Domain Ontology to oneM2M Base Ontology

# 3GPP TR 22.859 V1.0.0 (2021-03)

Technical Report

3rd Generation Partnership Project;  
Technical Specification Group Services and System Aspects;  
**Study on Personal Internet of Things (PIoT) networks  
(Release 18)**



# ETSI TS 103 410-8 V1.1.1 (2020-07)



Figure 11: SAREF and its extensions

SmartM2M;  
**Extension to SAREF;  
Part 8: eHealth/Ageing-well Domain**

# 3GPP and ETSI Smart M2M SAREF extensions 1 - 10 - 2

3GPP TR 22.859 V1.0.0 (2021-03)

Technical Report

3rd Generation Partnership Project;  
Technical Specification Group Services and System Aspects;  
**Study on Personal Internet of Things (PIoT) networks**  
(Release 18)



ETSI TS 103 410-8 V1.1.1 (2020-07)



SmartM2M;  
Extension to SAREF;  
**Part 8: eHealth/Ageing-well Domain**

ETSI TS 103 410-6 V1.1.2 (2020-05)





SmartM2M;  
Extension to SAREF;  
**Part 6: Smart Agriculture and Food Chain Domain**




# 3GPP and ETSI Smart M2M SAREF extensions 1 - 10 - 3

3GPP TR 22.859 V1.0.0 (2021-03)  
Technical Report

3rd Generation Partnership Project;  
Technical Specification Group Services and System Aspects;  
**Study on Personal Internet of Things (PIoT) network**  
(Release 18)

   
A GLOBAL INITIATIVE


ETSI TS 103 410-8 V1.1.1 (2020-07)



TECHNICAL SPECIFICATION

SmartM2M:  
Extension to SAREF;  
**Part 8: eHealth/Ageing-well Domain**

ETSI TS 103 410-6 V1.1.2 (2020-05)



TECHNICAL SPECIFICATION

SmartM2M:  
Extension to SAREF;  
**Part 6: Smart Agriculture and Food Chain Domain**

# ETSI TS 103 410-9 V1.1.1 (2020-07)




TECHNICAL SPECIFICATION

SmartM2M:  
Extension to SAREF;  
**Part 9: Wearables Domain**

# 3GPP and ETSI Smart M2M SAREF extensions 1 - 10 - 4

3GPP TR 22.859 V1.0.0 (2021-03)  
Technical Report

3rd Generation Partnership Project;  
 Technical Specification Group Services and System Aspects;  
**Study on Personal Internet of Things (PIoT) network**  
 (Release 18)




A GLOBAL INITIATIVE

ETSI TS 103 410-8 V1.1.1 (2020-07)



TECHNICAL SPECIFICATION

SmartM2M:  
 Extension to SAREF;  
**Part 8: eHealth/Ageing-well Domain**

ETSI TS 103 410-6 V1.1.2 (2020-05)



TECHNICAL SPECIFICATION

SmartM2M:  
 Extension to SAREF;  
**Part 6: Smart Agriculture and Food Chain Domain**

ETSI TS 103 410-9 V1.1.1 (2020-07)



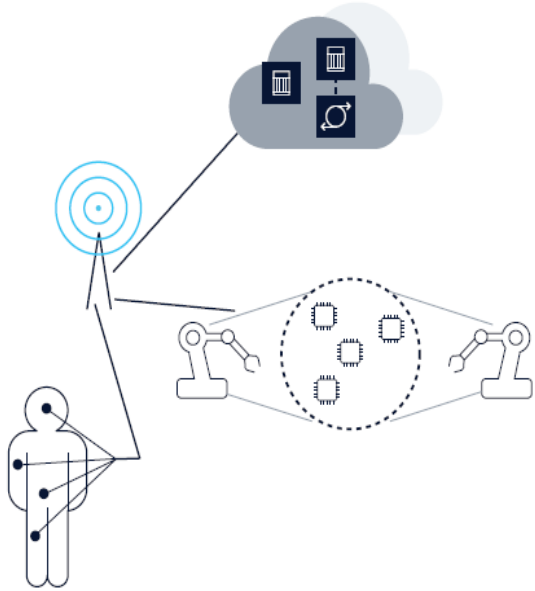
TECHNICAL SPECIFICATION

SmartM2M:  
 Extension to SAREF;  
**Part 9: Wearables Domain**



Figure 11: SAREF and its extensions

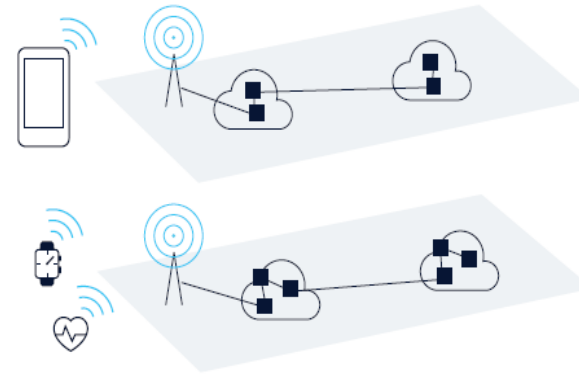
## 6G Architecture Themes



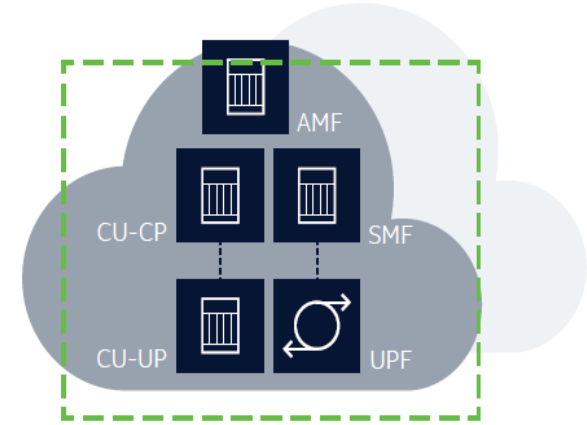
End point is a network



Cell free/mesh



Hyper-specialized slicing



RAN-Core convergence

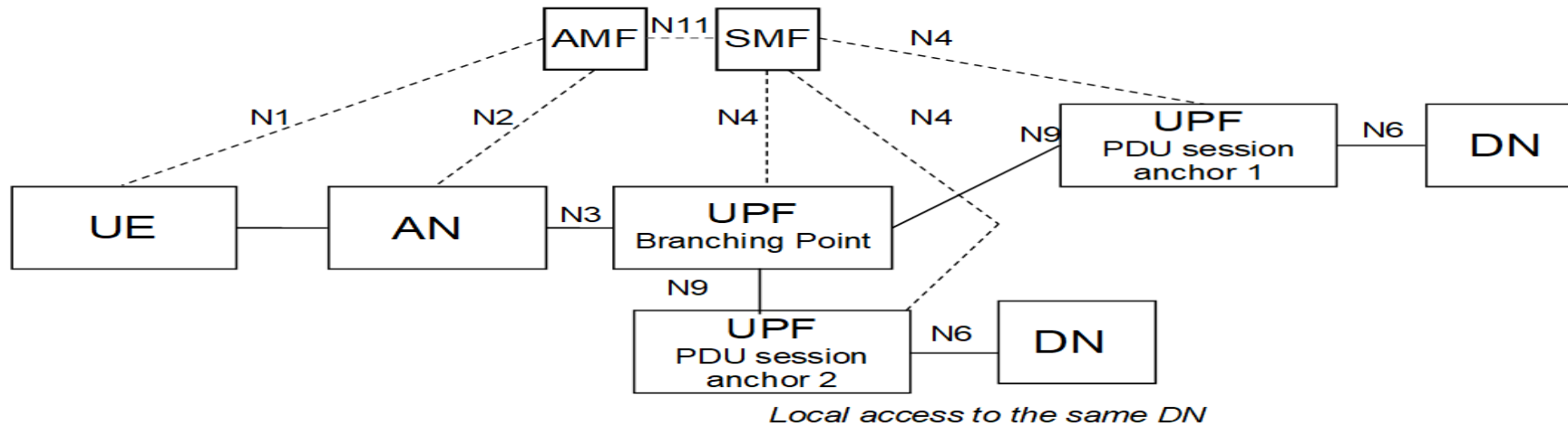
5GS Specifications there is a Set of New Functionalities that serves as Enablers for Edge Computing.



#### 4. 5G CN Local Area Data Network (LADN) Support

- LADN in a certain Service Area (SA) where the Applications are deployed.
- Access to a LADN is only available in a specific LADN SA (Service Area), defined as a Set of Tracking Areas (TAs) in the serving PLMN
- LADN is a Service provided by the serving PLMN of the UE.





**Figure 5.6.4.3-2: Multi-homed PDU Session: local access to same DN**

NOTE 3: It is possible for a given UPF to support both the Branching Point and the PDU Session Anchor functionalities.

## 5.6.5 Support for Local Area Data Network

The access to a DN via a PDU Session for a LADN is only available in a specific LADN service area. A LADN service area is a set of Tracking Areas. LADN is a service provided by the serving PLMN. It includes:

- LADN service applies only to 3GPP accesses and does not apply in Home Routed case.
- The usage of LADN DNN requires an explicit subscription to this DNN or subscription to a wildcard DNN.
- Whether a DNN corresponds to a LADN service is an attribute of a DNN and is per PLMN.

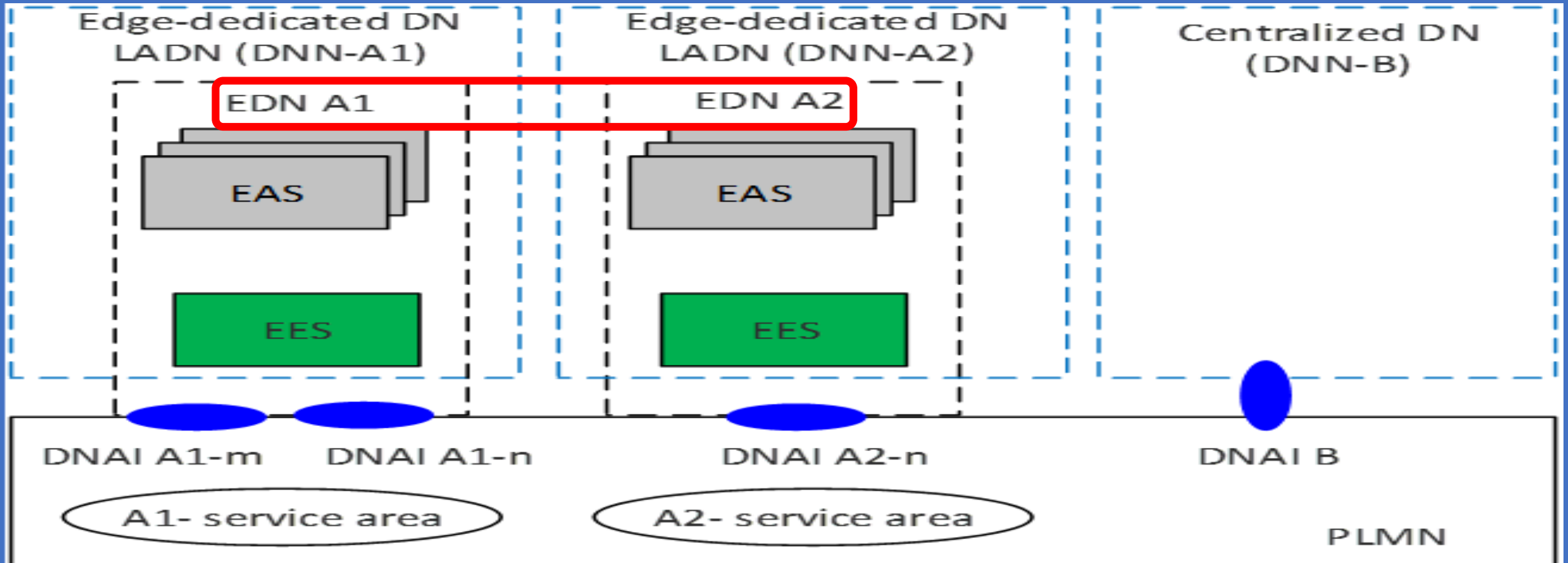
The UE is configured to know whether a DNN is a LADN DNN on a per-PLMN basis, and an association between application and LADN DNN. The configured association is considered to be a UE local configuration defined in TS 23.503 [45]. Alternatively, the UE gets the information whether a DNN is a LADN DNN from LADN Information during (re-)registration procedure as described in this clause.

## Use of 5G LADN (Local Area Data Network)

Edge Computing Services can be provided via **Edge-dedicated Data Networks (EDNs)** deployed as LADNs.

With this option, the PLMN supports Edge Computing Services in the EDN SAs which is equal to the LADN SA.

The LADN Service is the service that the Edge Computing is supported. Each individual EAS in the LADN can support the same or smaller SA than the LADN.



**Figure A.2.4-1: Option 3: Use of LADN(s)**

## 5.15.2.2

**Standardised SST values**

Standardized SST values provide a way for establishing global interoperability for slicing so that PLMNs can support the roaming use case more efficiently for the most commonly used Slice/Service Types.

The SSTs which are standardised are in the following Table 5.15.2.2-1.

**Table 5.15.2.2-1: Standardised SST values**

Slice/Service type	SST value	Characteristics
eMBB	1	Slice suitable for the handling of 5G enhanced Mobile Broadband.
URLLC	2	Slice suitable for the handling of ultra- reliable low latency communications.
MIoT	3	Slice suitable for the handling of massive IoT.
V2X	4	Slice suitable for the handling of V2X services.
HMTC	5	Slice suitable for the handling of High-Performance Machine-Type Communications.

NOTE 1: The support of all standardised SST values is not required in a PLMN. Services indicated in this table for each SST value can also be supported by means of other SSTs.

NOTE 2: A mapping of GSMA defined Network Slice Types (NEST) to standard SST values is defined in GSMA NG.116 [137].

### 5.15.3 Subscription aspects

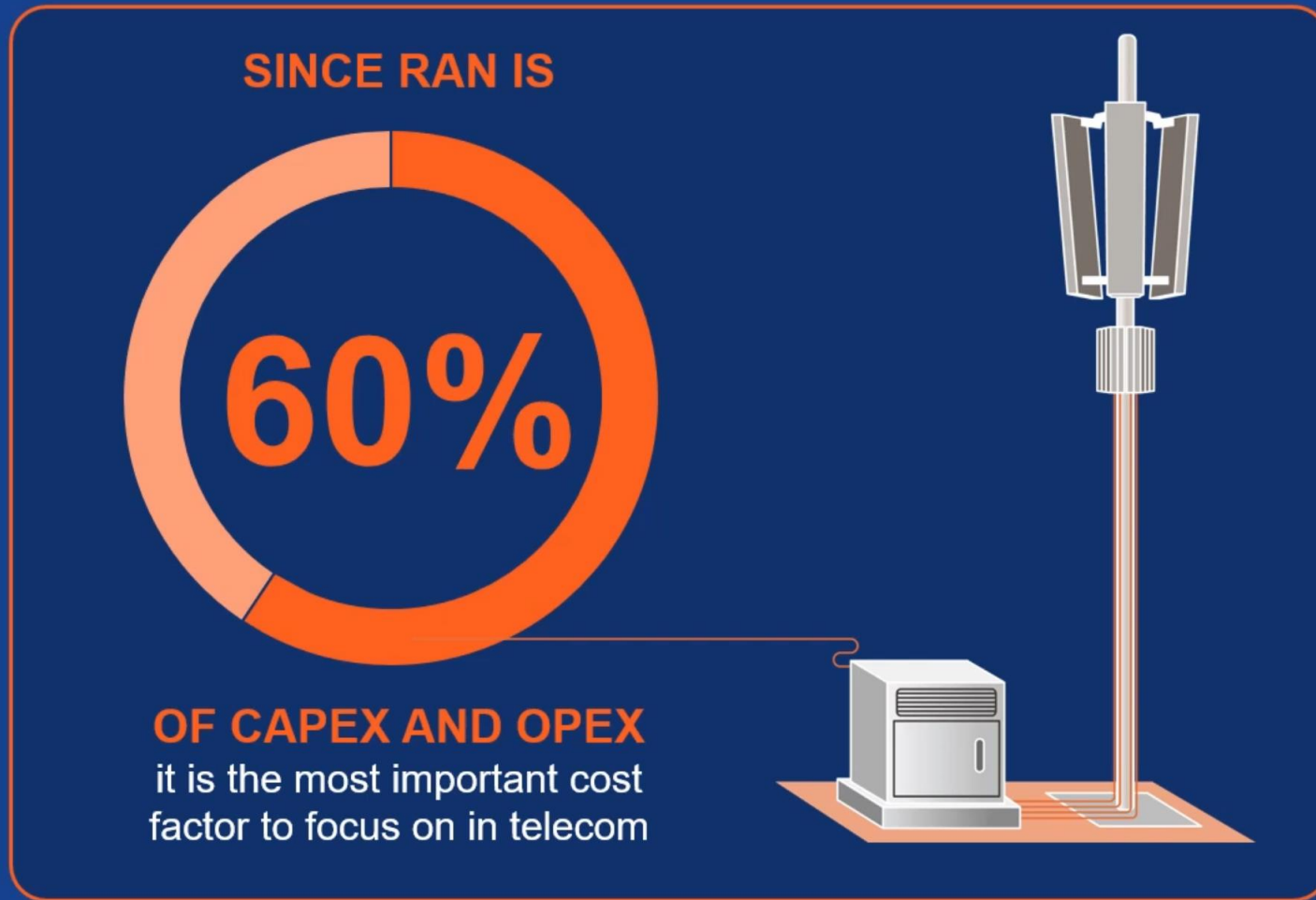
The Subscription Information shall contain one or more S-NSSAIs i.e. Subscribed S-NSSAIs. The UDM sends at the most 16 Subscribed S-NSSAIs to AMF, i.e. the number that can fit in a Configured NSSAI. Based on operator's policy, one or more Subscribed S-NSSAIs can be marked as a default S-NSSAI. If an S-NSSAI is marked as default, then the network is expected to serve the UE with a related applicable Network Slice instance when the UE does not send any permitted S-NSSAI to the network in a Registration Request message as part of the Requested NSSAI.

The Subscription Information for each S-NSSAI may contain:

- a Subscribed DNN list and one default DNN; and
- the indication whether the S-NSSAI is marked as default Subscribed S-NSSAI; and
- the indication whether the S-NSSAI is subject to Network Slice-Specific Authentication and Authorization; and

# WHY OPENRAN?

The Facebook TIP Open Compute Initiative started the movement towards OpenRAN—

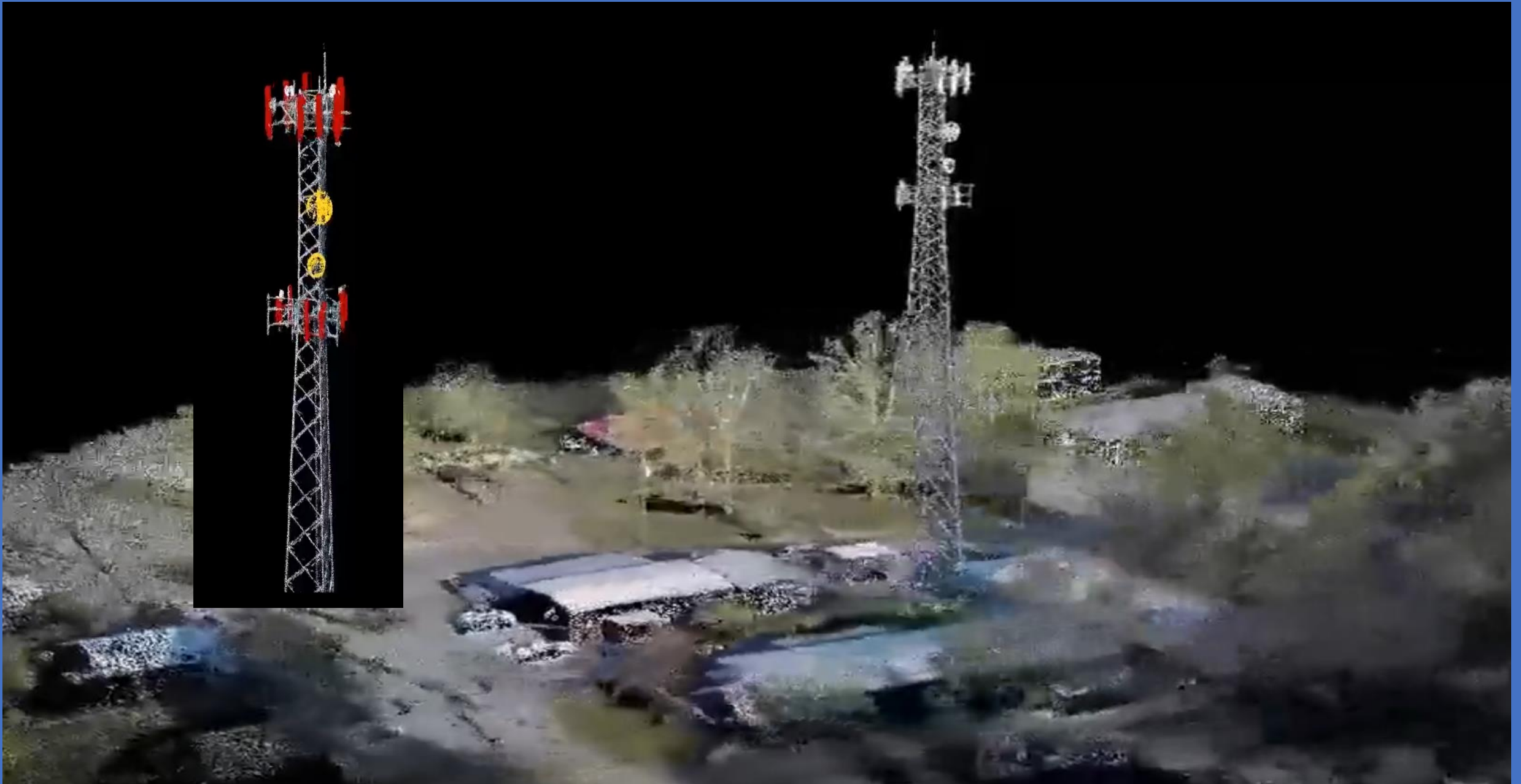




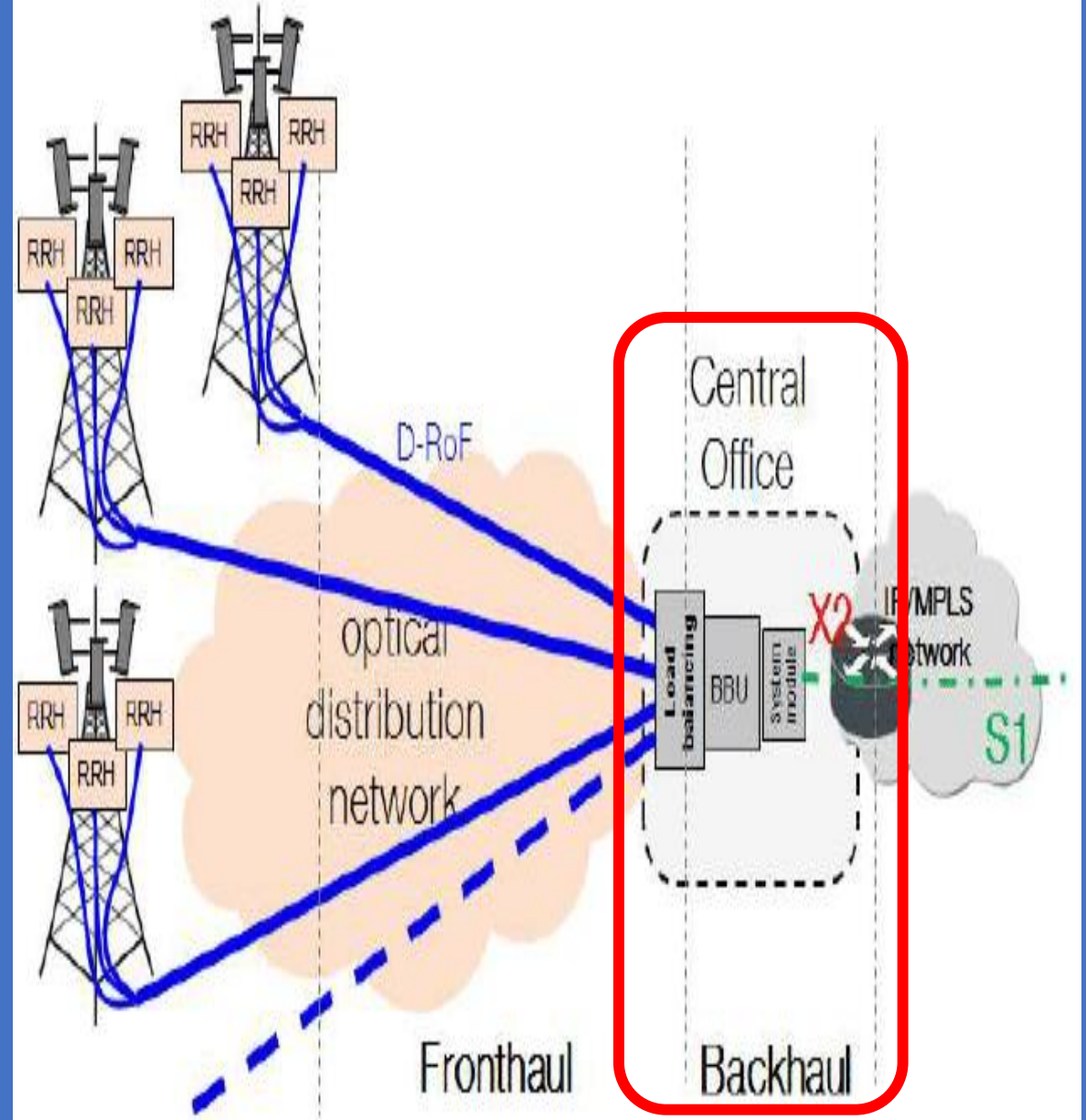
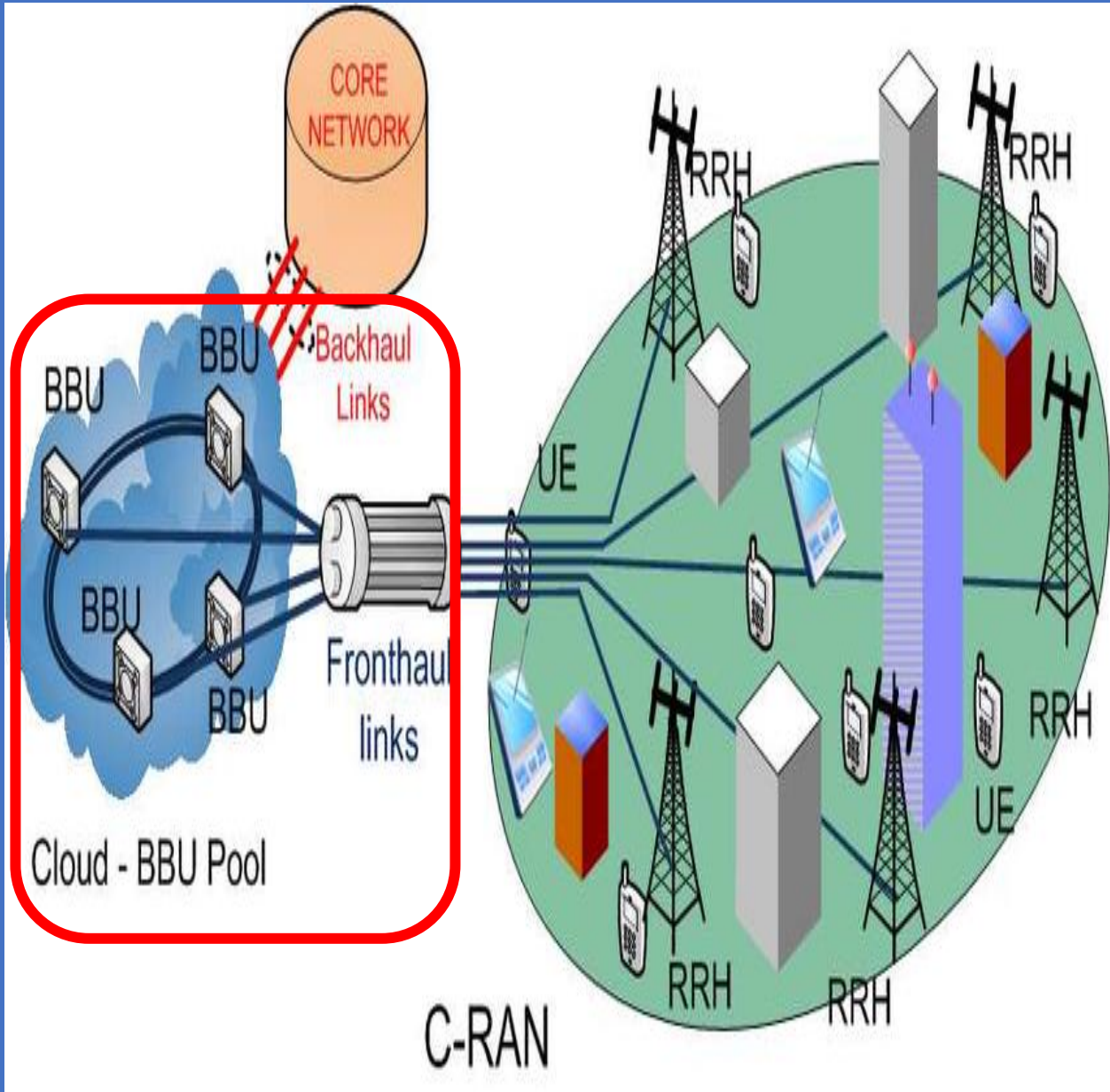


**Magnus Frodigh**  
Head of Ericsson Research

# Ericsson 6G Vision



# C-RAN

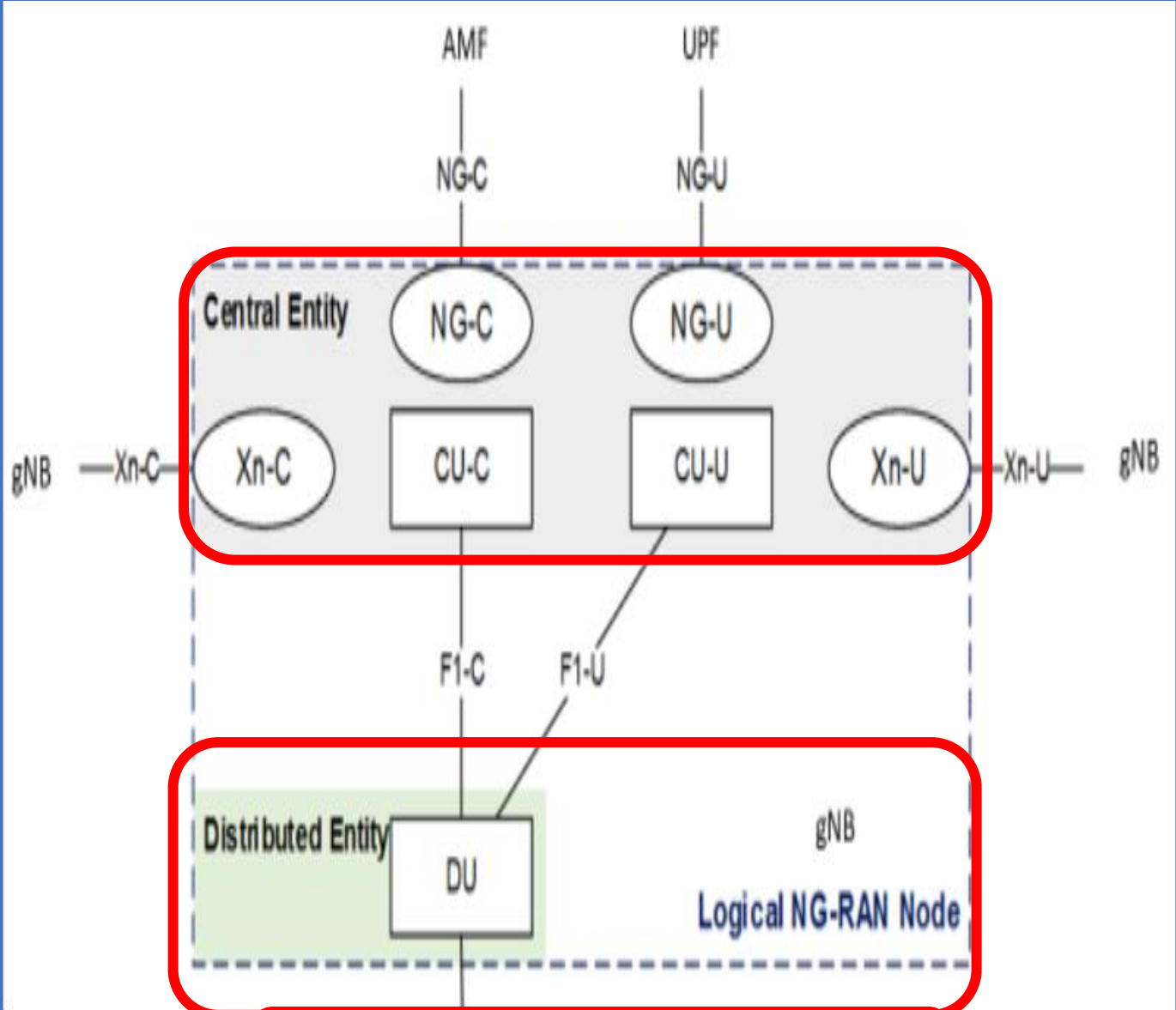
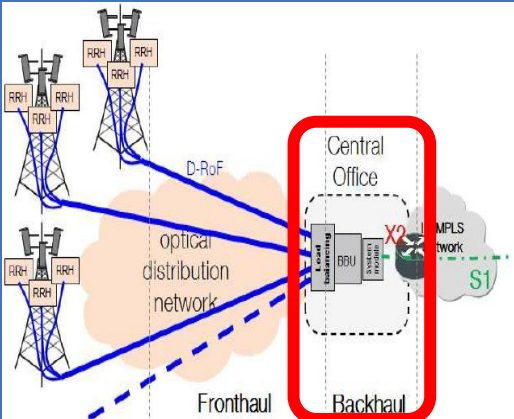


### 3GPP RAN gNB DU and CU Functional Split:

3GPP has also defined a functional split [13] inside the gNB with 2 components: the DU (Distributed Unit) and the CU (Centralized Unit), communicating via a standard interface F1.

The CU can also be split in 2 entities: a CU-C for CP and a CU-U for UP.

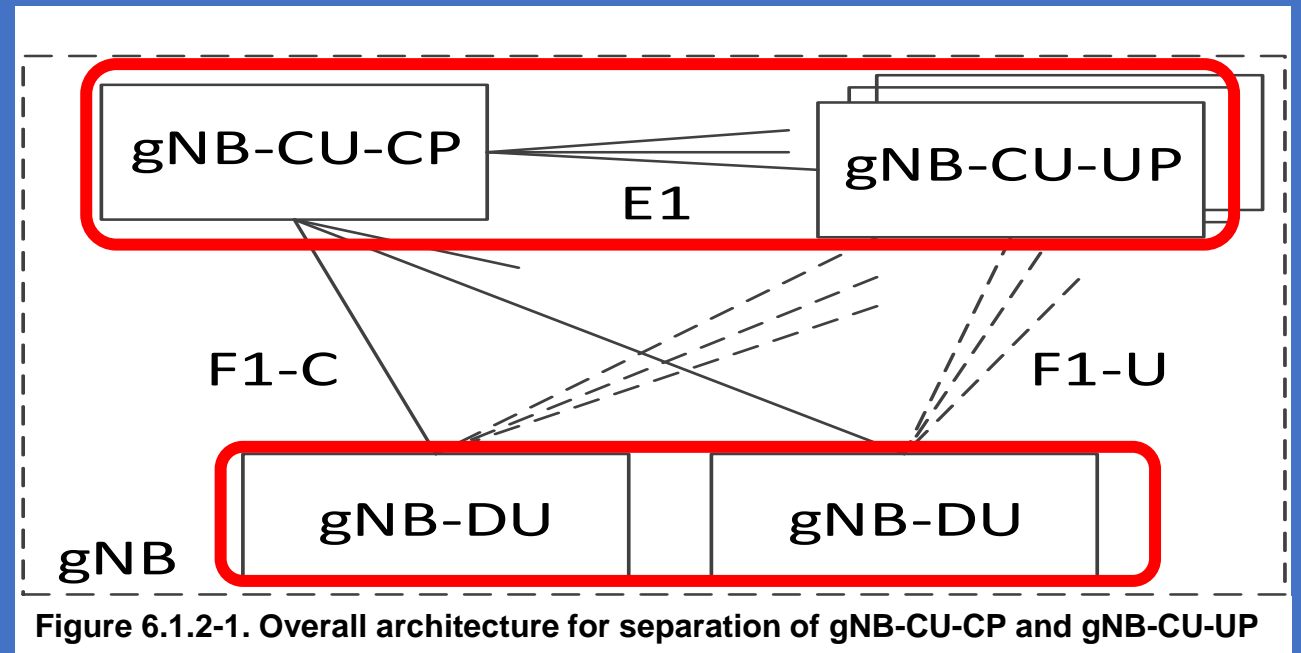
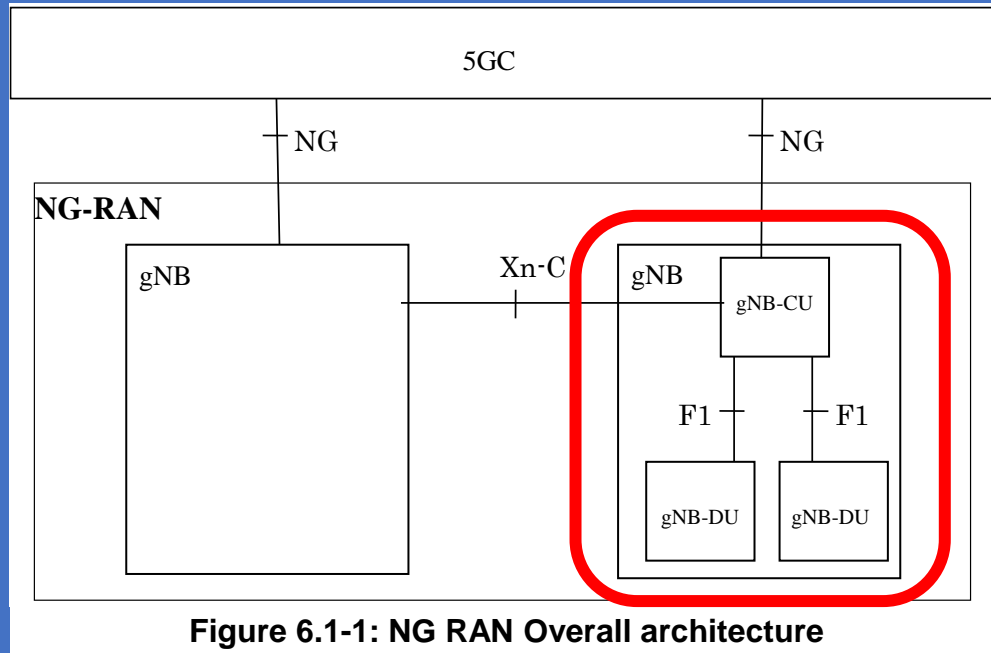
This architecture allows for the RAN to be more and more virtualized and a number of functions to run in the Cloud, either close to the Antenna on Edge Location if low latency is being required, or further down in more Centralized Data Centre with different Split Options between Central unit (CU) and Distributed Unit (DU).



**Figure 14: 3GPP DU CU Functional Split**

3GPP has defined the Architecture of the 5G Next Generation RAN (NG-RAN) with a Reference Architecture as described below with 2 keys Components:

- A gNB may consist of a gNB-CU and 1 or more gNB-DU(s). A gNB-CU and a gNB-DU is connected via F1 interface.  
One gNB-DU is connected to only one gNB-CU.
- gNB, providing 5G NR User Plane (UP) and Control Plane (CP) protocol terminations towards the UE



# O-RAN ALLIANCE

O-RAN Specifications are built based on the 3GPP Specifications by defining Interface Profiles, Additional New Open Interfaces, and New Nodes, in three (3) RAN Areas: Disaggregation, Automation, and Virtualization.

One of the Key New Interfaces standardized by O-RAN is Open Interface of Fronthaul (FH), connection between RU (Radio Unit) and DU (Distributed Unit).

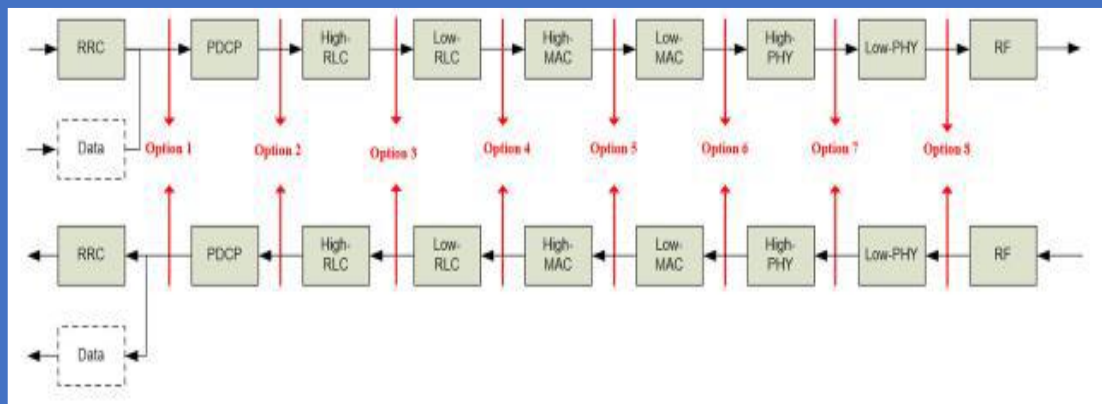


Figure 15: RAN Split Option

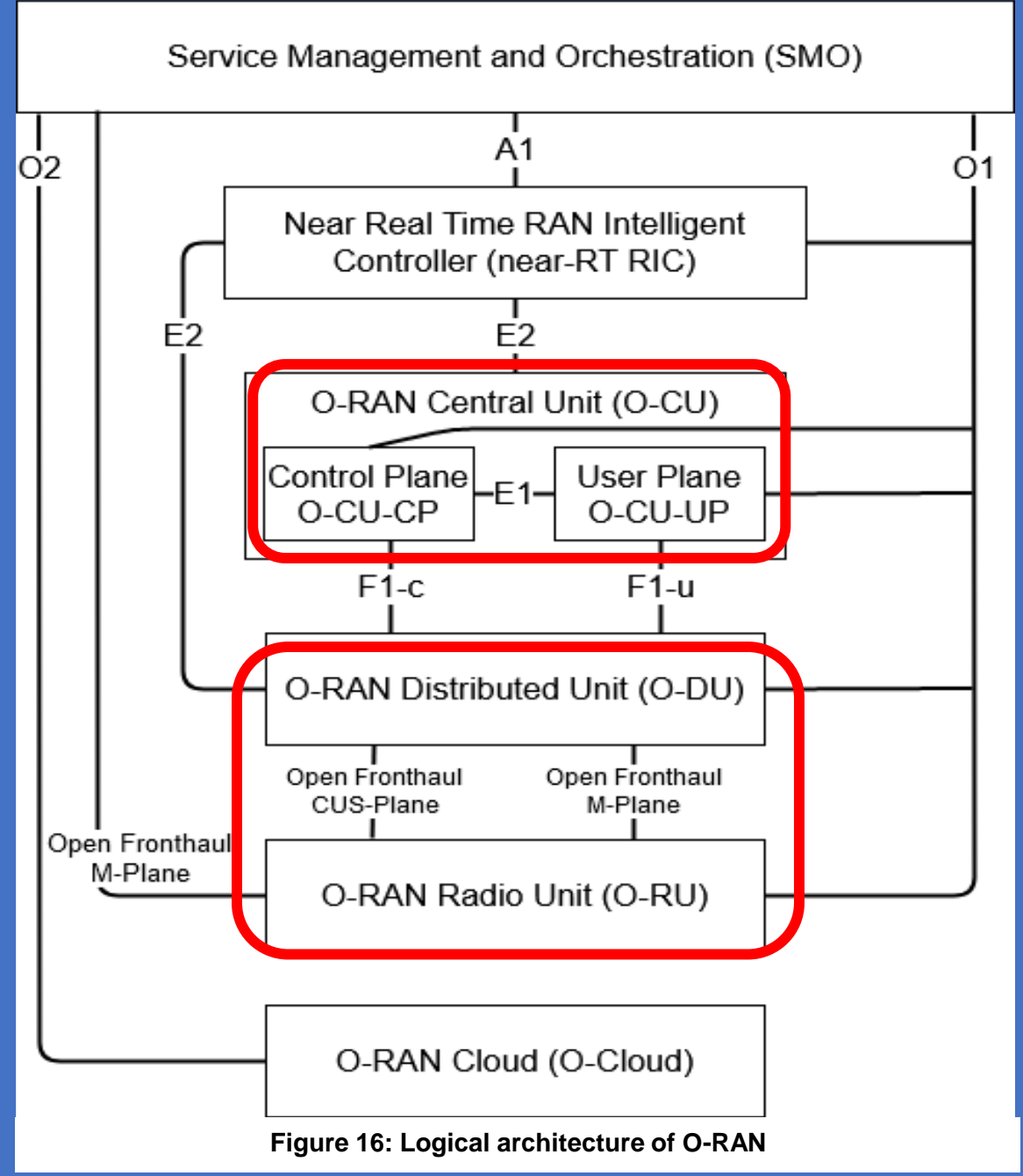


Figure 16: Logical architecture of O-RAN

# O-RAN Alliance Control Loops: Non/Near/Real-time Control Loops

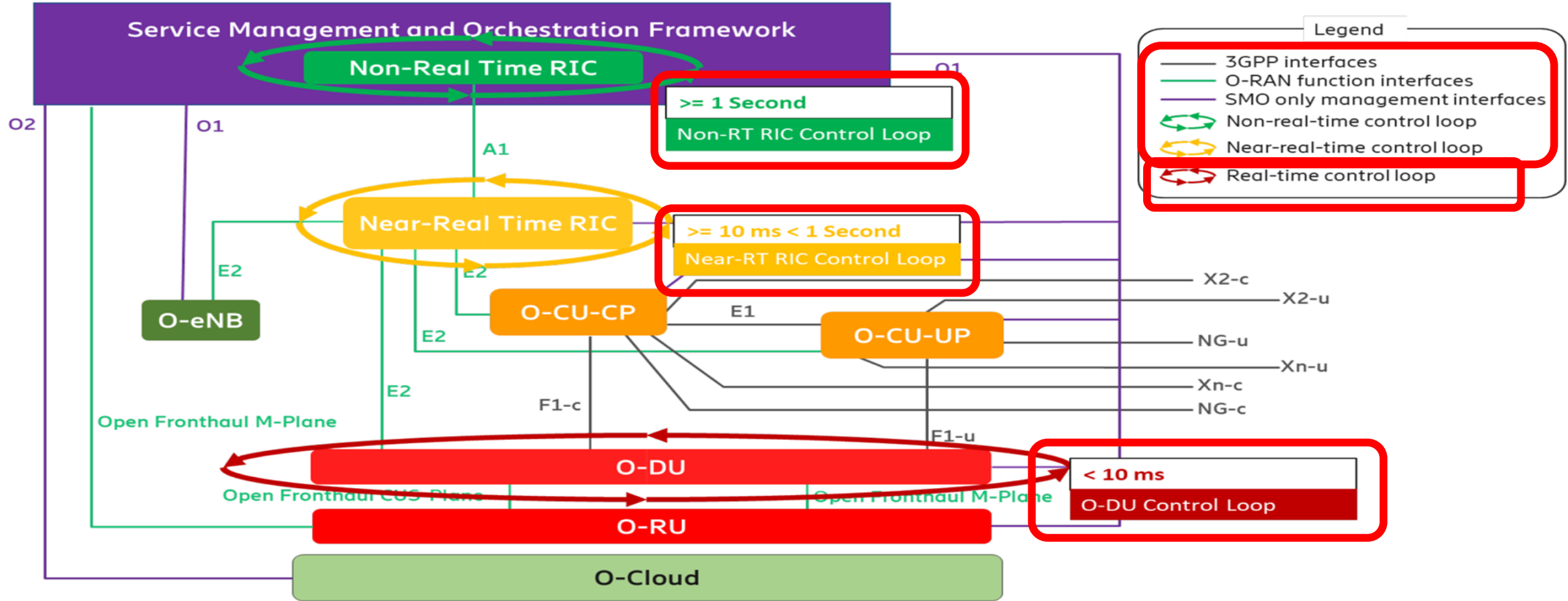
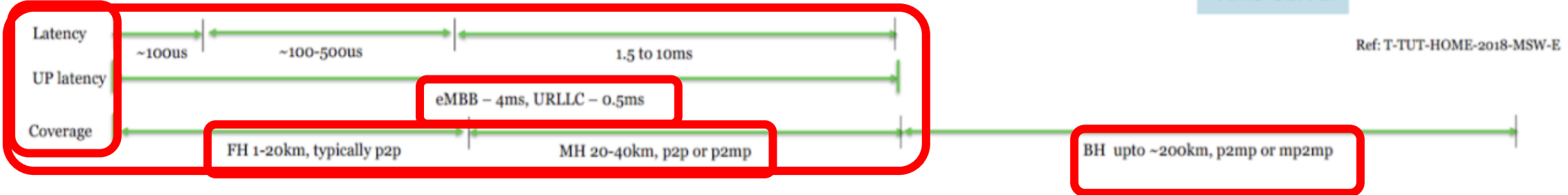
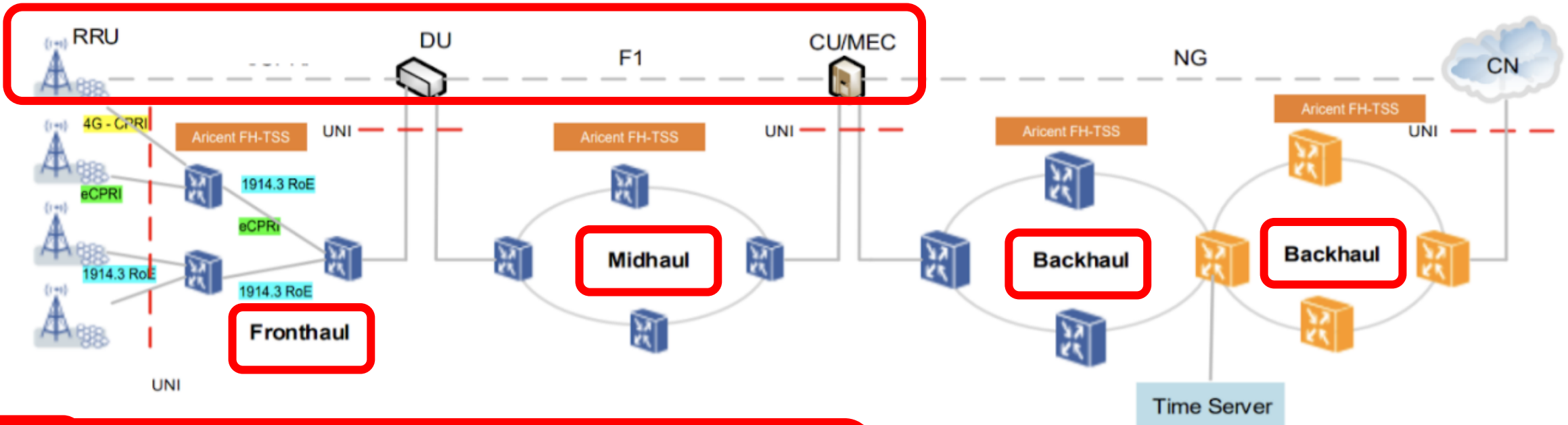


Figure 4.2-1: O-RAN Control Loops

# RAN Latency and Distance in FH, MH, BH



- ✓ Fronthaul – Network between RRU/RU (Remote Unit) and DU (Distributed Unit) – can be CPRI or eCPRI or IEEE 1914.3
- ✓ Midhaul – Network between DU and CU (Centralized Unit) – “F interface”
- ✓ Backhaul – Network between CU and 5G NGC (and EPC)

Source: Altran (Aricent)

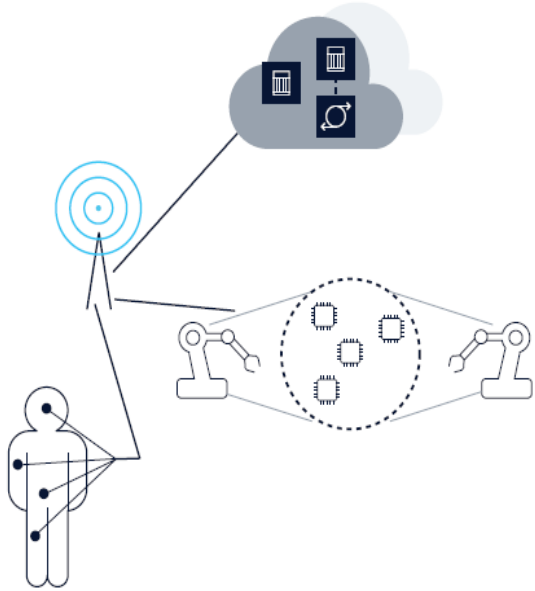


1

3

2

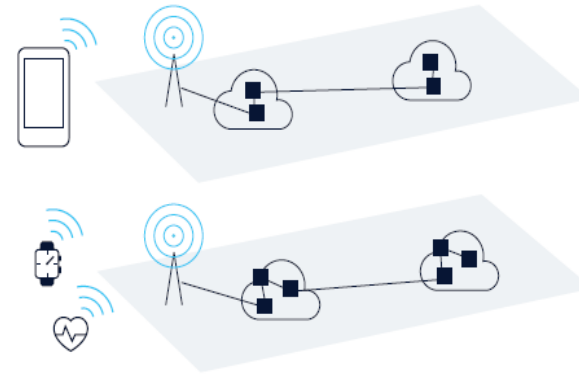
### 6G Architecture Themes



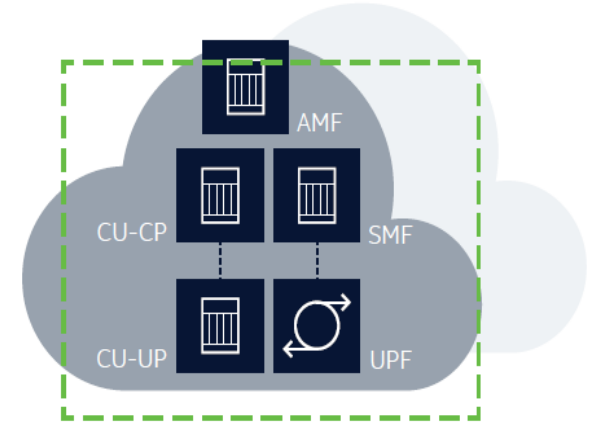
End point is a network



Cell free/mesh



Hyper-specialized slicing



RAN-Core convergence

# Cell-Free Massive MIMO versus Small Cells

Hien Quoc Ngo, Alexei Ashikhmin, Hong Yang, Erik G. Larsson, and Thomas L. Marzetta

**Abstract**—A Cell-Free Massive MIMO (multiple-input multiple-output) system comprises a very large number of distributed access points (APs) which simultaneously serve a much smaller number of users over the same time/frequency resources based on directly measured channel characteristics. The APs and users have only one antenna each. The APs acquire channel state information through time-division duplex operation and the reception of uplink pilot signals transmitted by the users. The APs perform multiplexing/de-multiplexing through conjugate beamforming on the downlink and matched filtering on the uplink. Closed-form expressions for individual user uplink and downlink throughputs lead to max-min power control algorithms. Max-min power control ensures uniformly good service throughout the area of coverage. A pilot assignment algorithm helps to mitigate the effects of pilot contamination, but power control is far more important in that regard.

Cell-Free Massive MIMO has considerably improved performance with respect to a conventional small-cell scheme, whereby each user is served by a dedicated AP, in terms of both 95%-likely per-user throughput and immunity to shadow fading spatial correlation. Under uncorrelated shadow fading conditions, the cell-free scheme provides nearly 5-fold improvement in 95%-likely per-user throughput over the small-cell scheme, and 10-fold improvement when shadow fading is correlated.

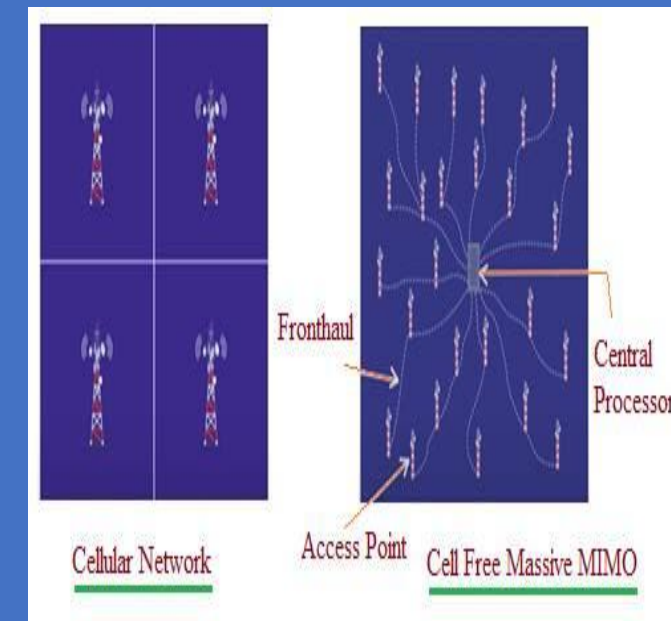
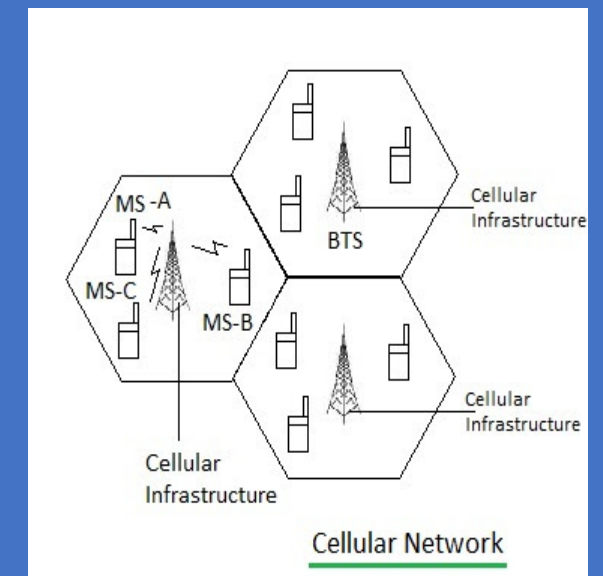
**Index Terms**—Cell-Free Massive MIMO system, conjugate beamforming, Massive MIMO, network MIMO, small cell.

## I. INTRODUCTION

to more efficiently exploit diversity against the shadow fading, distributed systems can potentially offer much higher probability of coverage than collocated Massive MIMO [4], at the cost of increased backhaul requirements.

In this work, we consider a distributed Massive MIMO system where a large number of service antennas, called access points (APs), serve a much smaller number of autonomous users distributed over a wide area [1]. All APs cooperate phase-coherently via a backhaul network, and serve all users in the same time-frequency resource via time-division duplex (TDD) operation. There are no cells or cell boundaries. Therefore, we call this system “Cell-Free Massive MIMO”. Since Cell-Free Massive MIMO combines the distributed MIMO and Massive MIMO concepts, it is expected to reap all benefits from these two systems. In addition, since the users now are close to the APs, Cell-Free Massive MIMO can offer a high coverage probability. Conjugate beamforming/matched filtering techniques, also known as maximum-ratio processing, are used both on uplink and downlink. These techniques are computationally simple and can be implemented in a distributed manner, that is, with most processing done locally at the APs.<sup>1</sup>

In Cell-Free Massive MIMO, there is a central processing unit (CPU), but the information exchange between the APs and this CPU is limited to the payload data, and power control coefficients that change slowly. There is no sharing



(12) INTERNATIONAL APPLICATION PUBLISHED UNDER THE PATENT COOPERATION TREATY (PCT)

(19) World Intellectual Property Organization

International Bureau



(10) International Publication Number

WO 2018/103897 A1

(43) International Publication Date  
14 June 2018 (14.06.2018)

(51) International Patent Classification:  
H04B 7/0452 (2017.01) H01Q 1/22 (2006.01)  
H04B 7/04 (2017.01) H01Q 1/46 (2006.01)  
H04W 88/08 (2009.01) H01Q 21/08 (2006.01)  
H01Q 21/29 (2006.01) H01Q 1/38 (2006.01)  
H01Q 25/00 (2006.01)

(21) International Application Number:  
PCT/EP2017/051669

(22) International Filing Date:  
26 January 2017 (26.01.2017)

(25) Filing Language: English

(26) Publication Language: English

(30) Priority Data:  
16203149.6 09 December 2016 (09.12.2016) EP

(71) Applicant: TELEFONAKTIEBOLAGET L M ERICSSON (PUBL) [SE/SE]; 164 83 STOCKHOLM (SE).

(72) Inventors: FRENGER, Patri; Enskingesgatan 8, 583 34 Linköping (SE). HEDEREN, Jan; Nartomta Storgård, 585 62 Linghem (SE). HESSLER, Martin; Kompanigatan 16, 587 58 Linköping (SE). INTERDONATO, Giovanni; Rydsvägen 98C, 584 31 Linköping (SE).

(74) Agent: STRÖM & GULLIKSSON AB; P.O. Box 4188, SE-203 13 Malmö (SE).

(81) Designated States (unless otherwise indicated, for every kind of national protection available): AE, AG, AL, AM, AO, AT, AU, AZ, BA, BB, BG, BH, BN, BR, BW, BY, BZ, CA, CH, CL, CN, CO, CR, CU, CZ, DE, DJ, DK, DM, DO, DZ, EC, EE, EG, ES, FI, GB, GD, GE, GH, GM, GT, HN, HR, HU, ID, IL, IN, IR, IS, JP, KE, KG, KH, KN, KP, KR, KW, KZ, LA, LC, LK, LR, LS, LU, LY, MA, MD, ME, MG, MK, MN, MW, MX, MY, MZ, NA, NG, NI, NO, NZ, OM, PA, PE, PG, PH, PL, PT, QA, RO, RS, RU, RW, SA, SC, SD, SE, SG, SK, SL, SM, ST, SV, SY, TH, TJ, TM, TN, TR, TT, TZ, UA, UG, US, UZ, VC, VN, ZA, ZM, ZW.

(84) Designated States (unless otherwise indicated, for every kind of regional protection available): ARIPO (BW, GH, GM, KE, LR, LS, MW, MZ, NA, RW, SD, SL, ST, SZ, TZ, UG, ZM, ZW), Eurasian (AM, AZ, BY, KG, KZ, RU, TJ, TM), European (AL, AT, BE, BG, CH, CY, CZ, DE, DK, EE, ES, FI, FR, GB, GR, HR, HU, IE, IS, IT, LT, LU, LV, MC, MK, MT, NL, NO, PL, PT, RO, RS, SE, SI, SK, SM, TR), OAPI (BF, BJ, CF, CG, CI, CM, GA, GN, GQ, GW, KM, ML, MR, NE, SN, TD, TG).

Published:  
— with international search report (Art. 21(3))

(54) Title: IMPROVED ANTENNA ARRANGEMENT FOR DISTRIBUTED MASSIVE MIMO

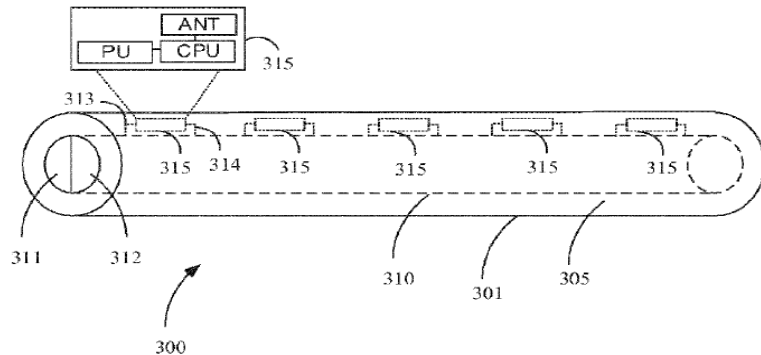
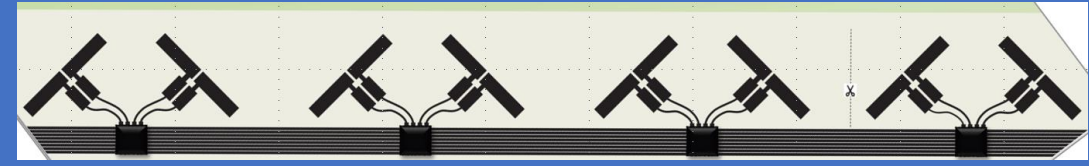


Fig. 3

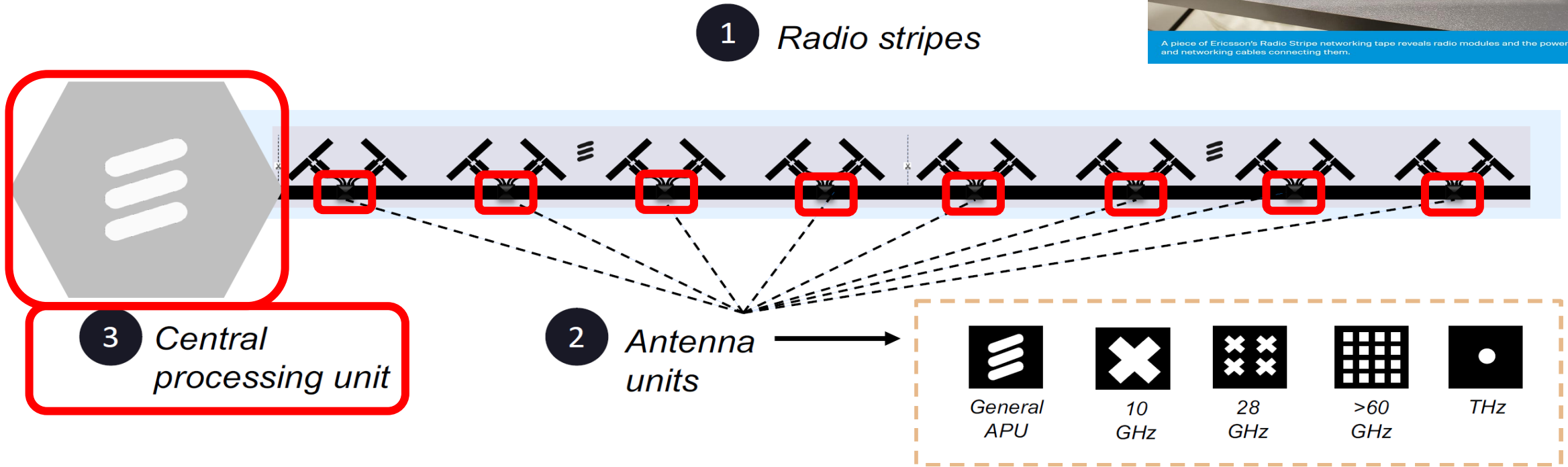


A piece of Ericsson's Radio Stripe networking tape reveals radio modules and the power and networking cables connecting them.



897 A1

## Implementation Architecture: Radio Stripes



Can create as long stripes as we need

# Ericsson Cell Free Radio Stripes



Pål Frenger, Radio Network Energy Performance Manager at Ericsson Research



A piece of Ericsson's Radio Stripe networking tape reveals radio modules and the power and networking cables connecting them.

Ref. Digital Trends, Ericsson 5G Radio Stripe Network MWC 2019 & Linköpings Universitet, Wireless communication by the metre, Dec. 2019

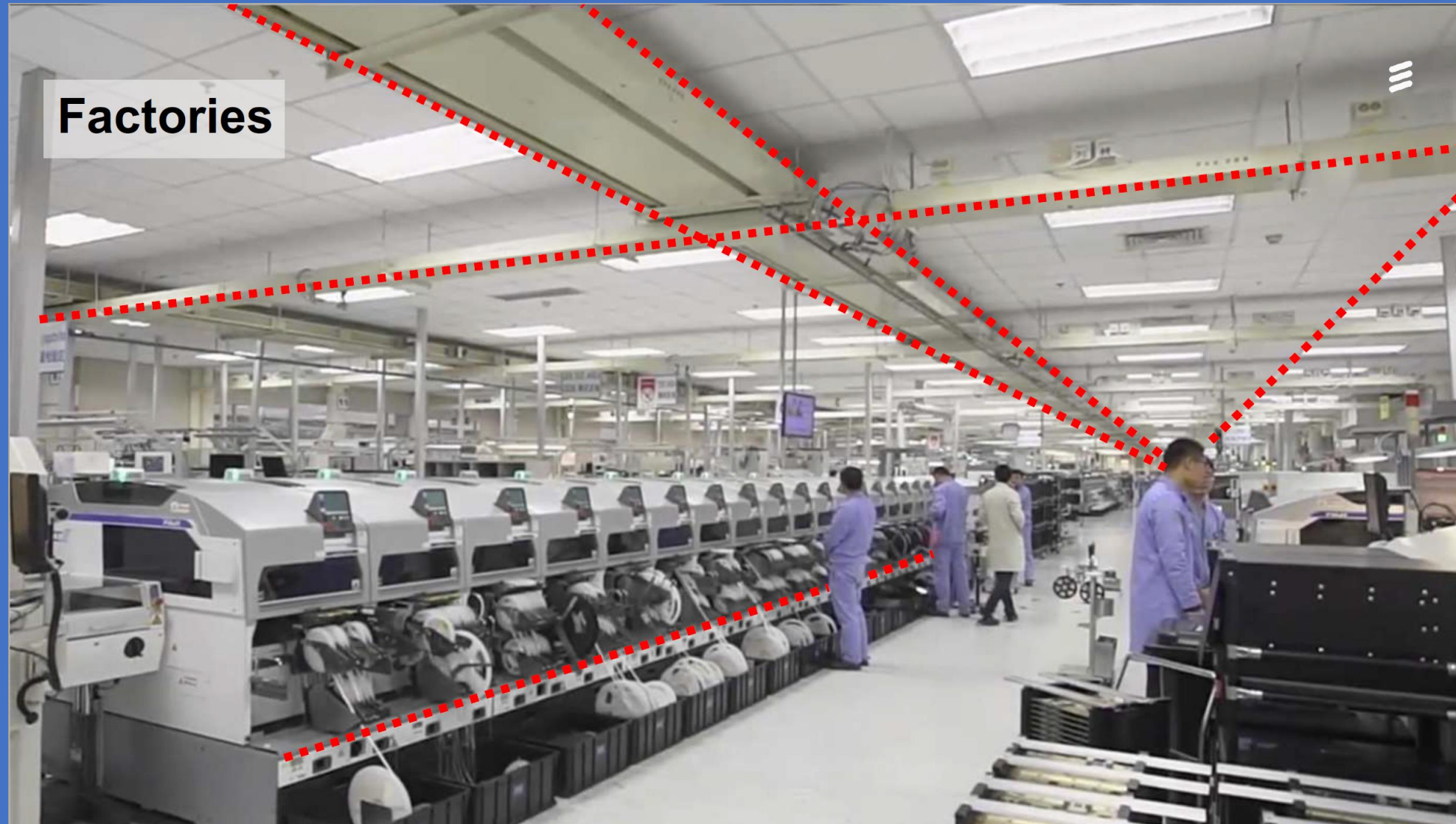
# Ericsson Cell Free Radio Stripes Use Cases (UCs) - 1



## Ericsson Cell Free Radio Stripes Use Cases (UCs) - 2



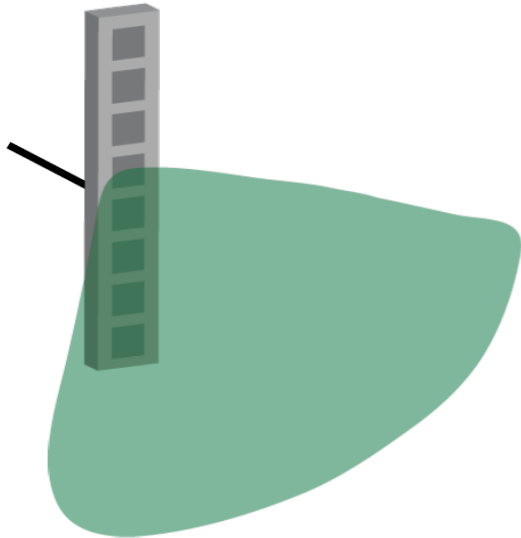
## Ericsson Cell Free Radio Stripes Use Cases (UCs) - 2





## Massive MIMO: 5G Attempt to Improve Spectral Efficiency

1 high-gain antenna

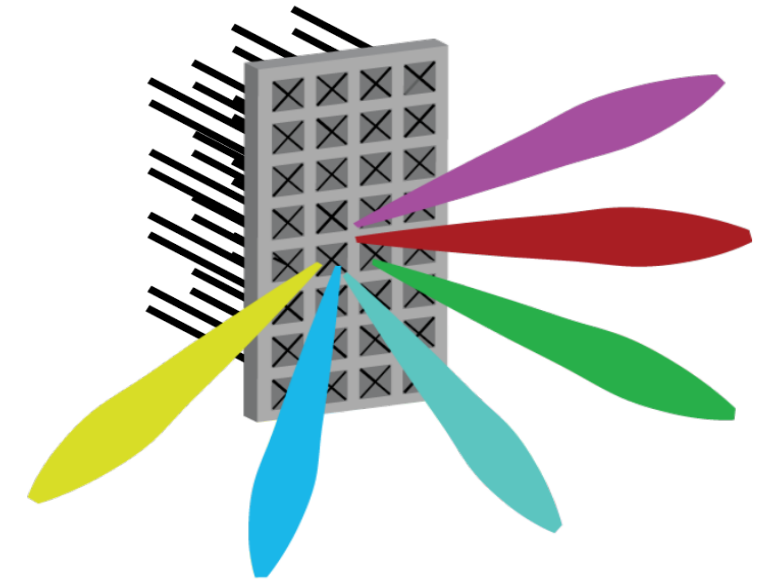


**Classical antenna**

Always the same directivity



64 low-gain antennas



**“Massive MIMO”**

Strong, adaptive directivity

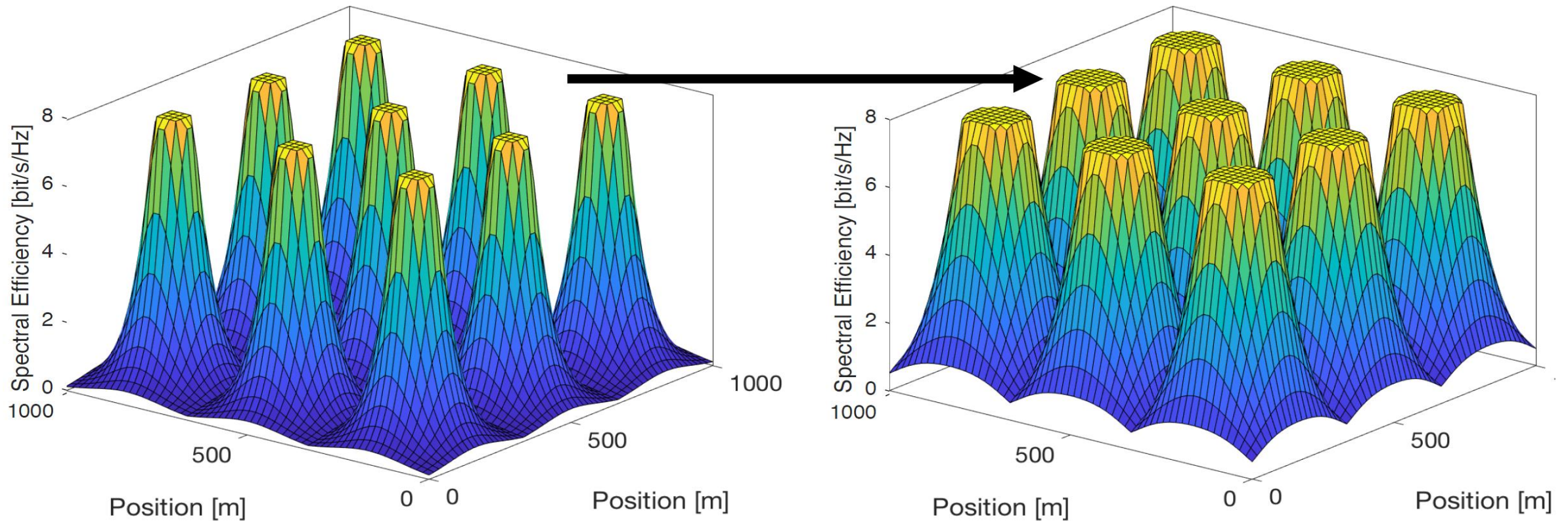
Separate users in space

Reduce interference

**Massive MIMO**  
(multiple-input multiple-output):  
 $M$  antennas  $\gg$   $K$  users

# Can 5G Deliver Uniformly Good Service Everywhere?

Handles more users and give stronger signals, but problems remain!

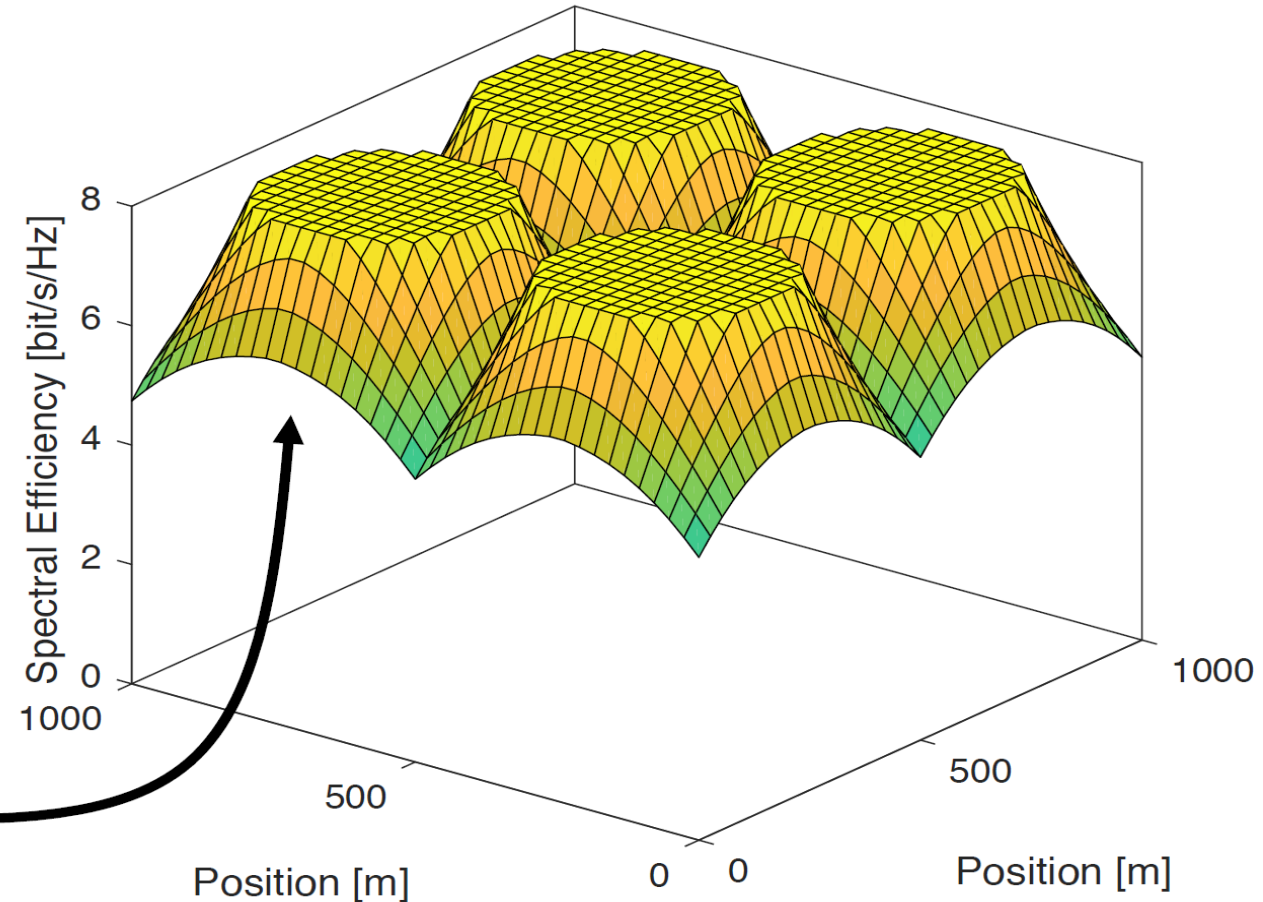


**mmWave bands: Worse signal variations!**

# Wireless Dream: (Almost) Uniformly Good Service Quality

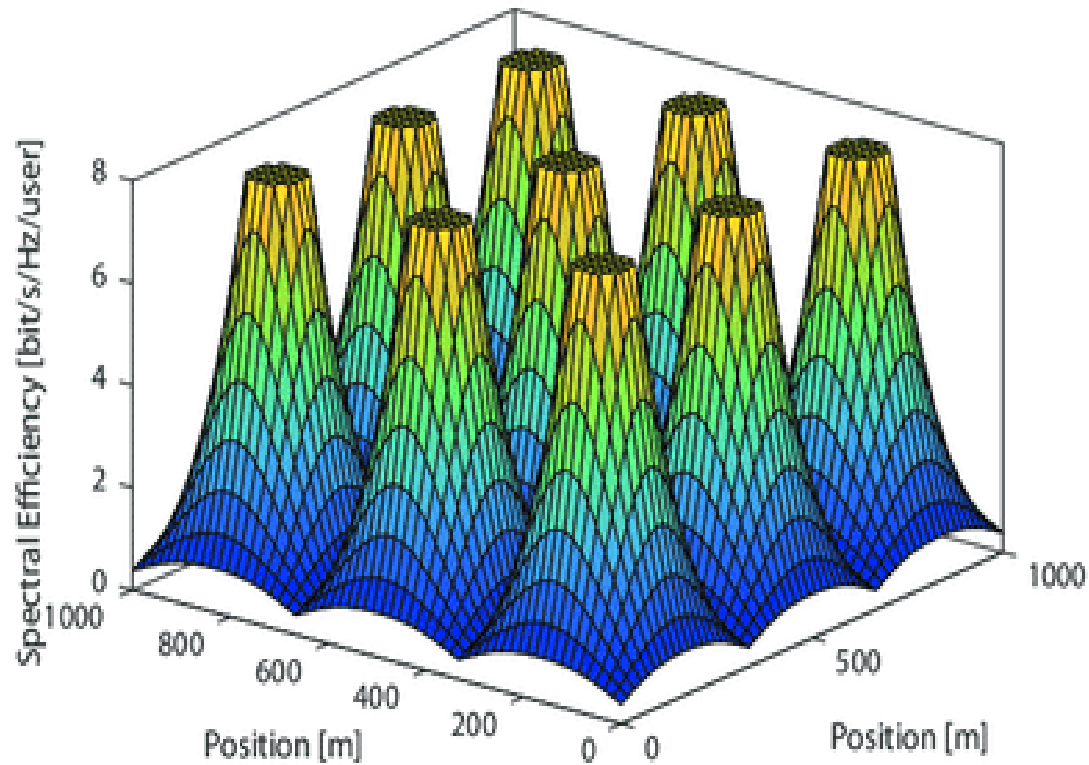
Users request same service everywhere

**Easy to serve users in cell center**  
Most *active users* are at cell edge!

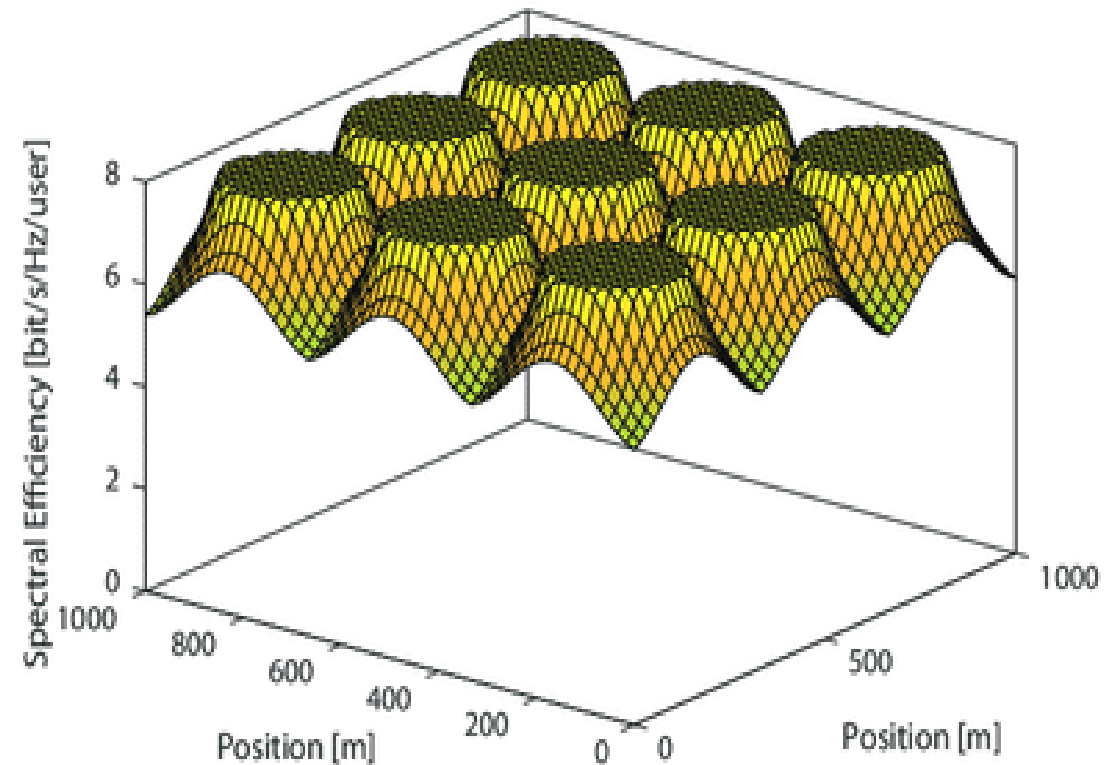


**Can we deliver this somehow?**

# Ericsson Cell Free Radio Stripes



Data Coverage: Left: Cellular Network.

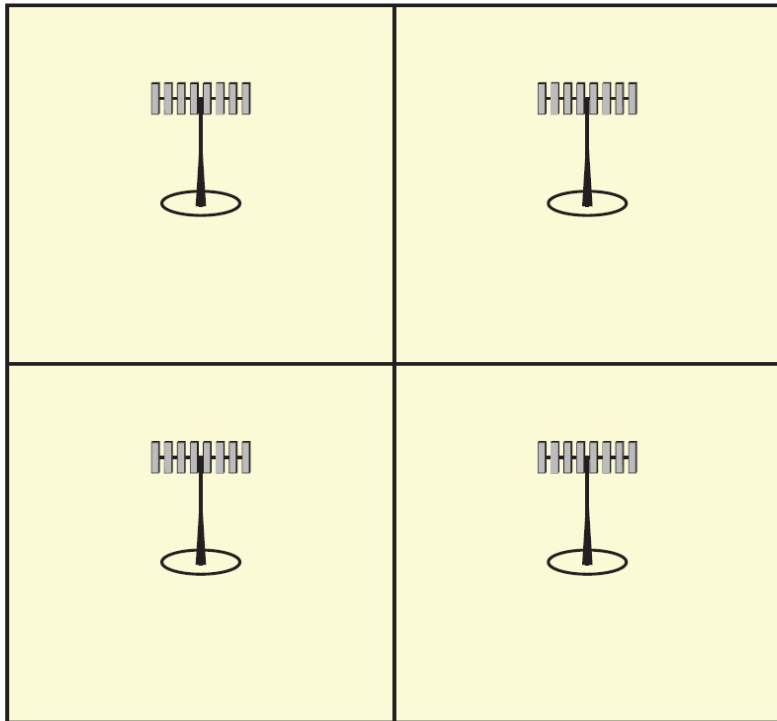


Right: Cell-Free Massive MIMO Network.

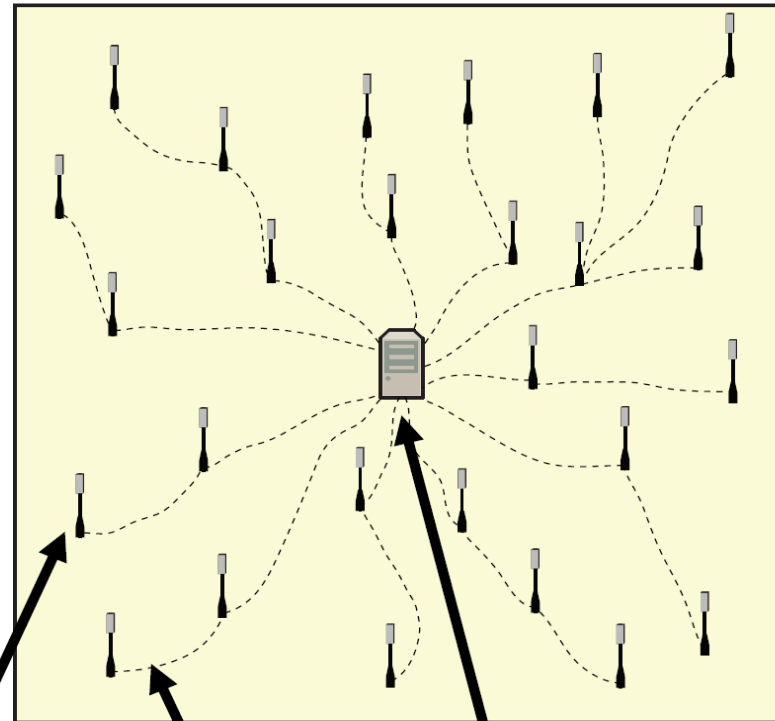
SE achieved by UEs at different locations in an Area covered by nine (9) APs that are deployed on a regular grid. Note that 8 bit/s/Hz was selected as the maximal SE, which corresponds to uncoded 256-QAM.

# Moving Beyond the Cellular Paradigm

## Cellular network



## Cell-free network

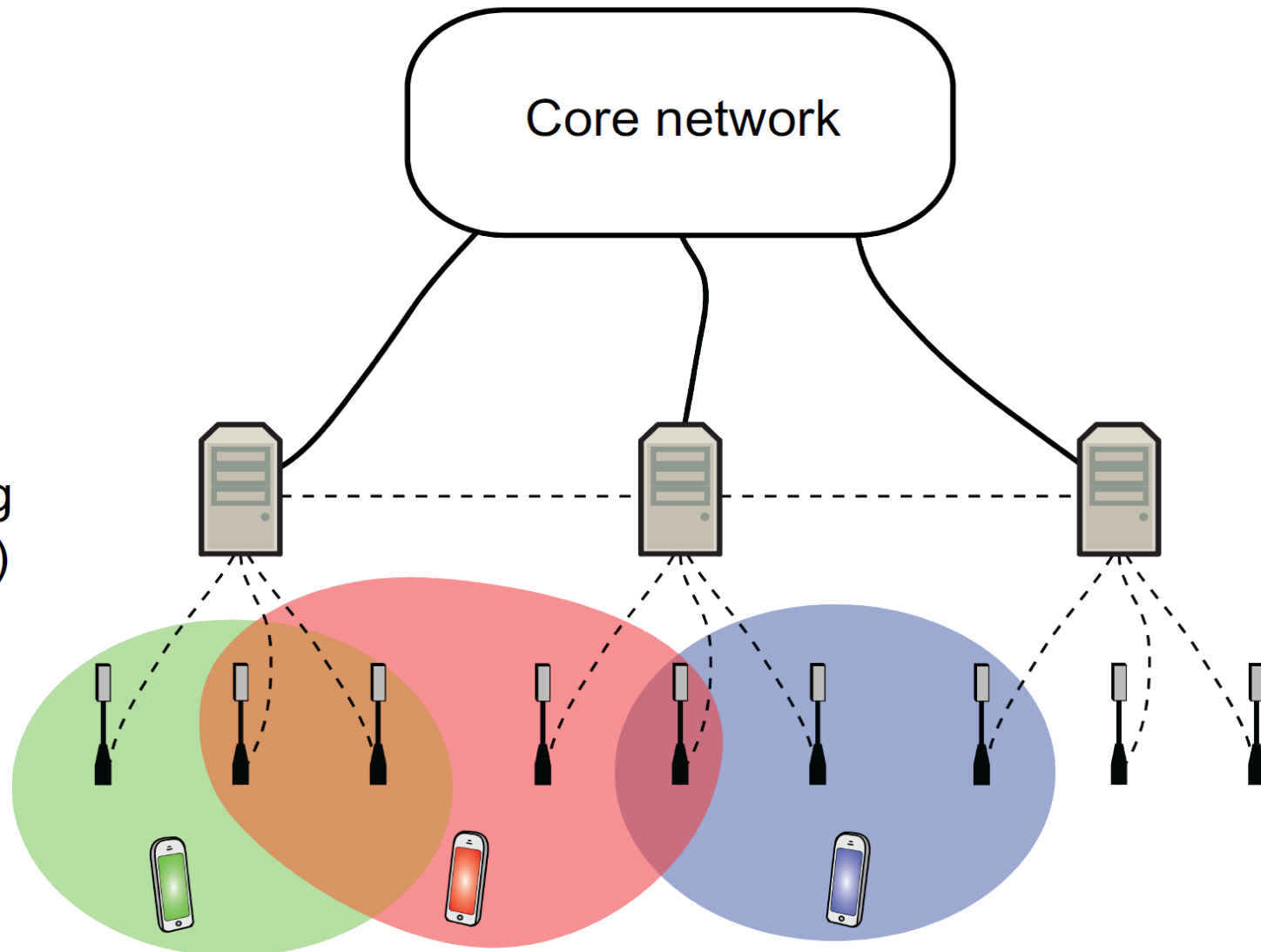


**Massive number of distributed antennas:**  
Short distance from user to some antennas

**Connection to Massive MIMO:**  
 $M \gg K$   
 $M$  antennas,  $K$  users

Access point      Fronthaul      Central processing unit

# Signal Processing: Centralized versus Distributed



**Processing tasks**  
Channel estimation  
Precoding/combining  
Data en-/de-coding

**Centralized version**  
Every done at a CPU

**Distributed version**  
Most processing at AP, fusing of signals at a CPU

Central processing unit (CPU)

Access point (AP)

# Ericsson Cell Free Radio Stripes



Pål Frenger, Radio Network Energy Performance Manager at Ericsson Research



A piece of Ericsson's Radio Stripe networking tape reveals radio modules and the power and networking cables connecting them.

Ref. Digital Trends, Ericsson 5G Radio Stripe Network MWC 2019 & Linköpings Universitet, Wireless communication by the metre, Dec. 2019

# Ericsson Cell Free Radio Stripes Use Cases (UCs) - 1

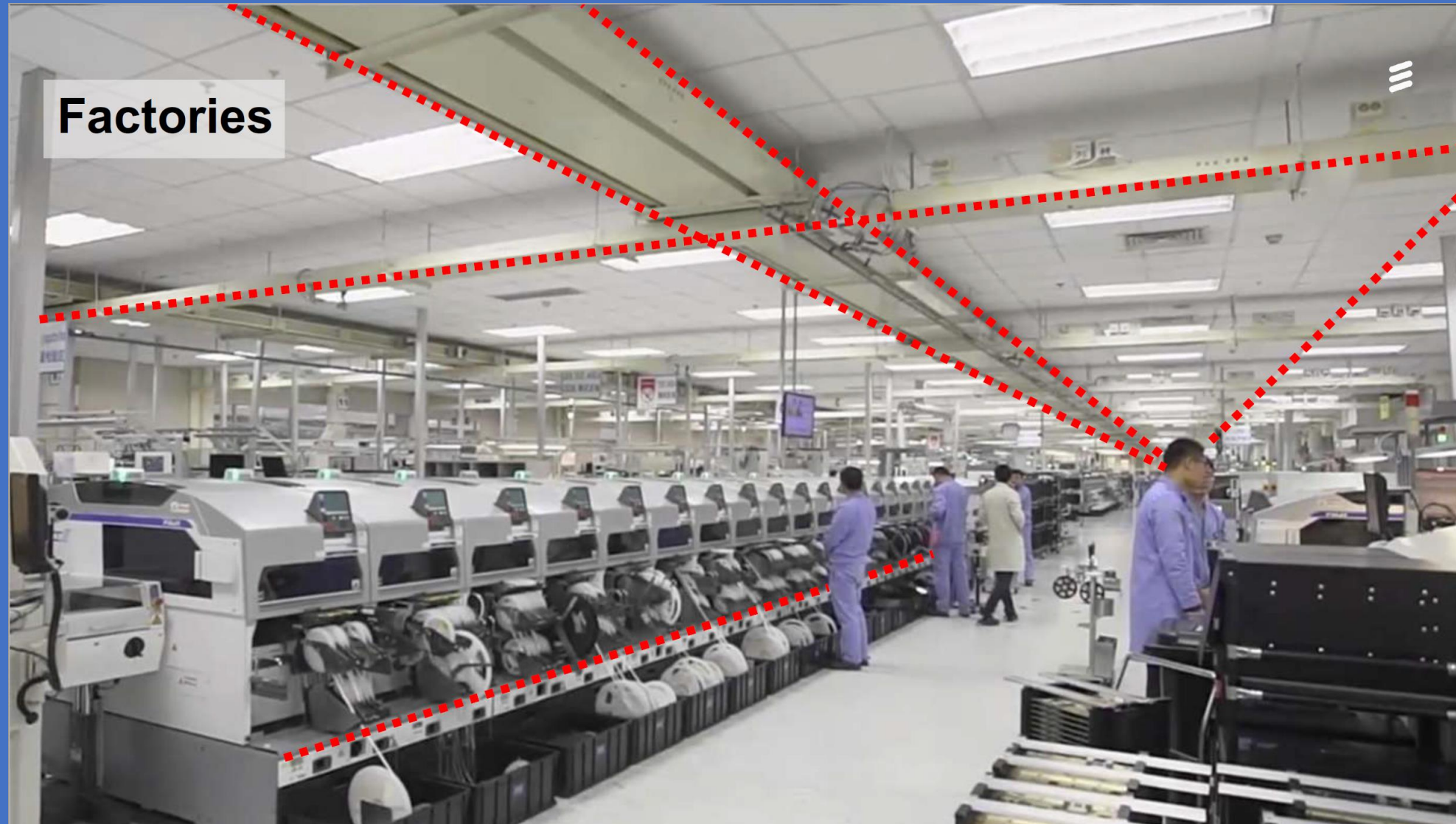




## Ericsson Cell Free Radio Stripes Use Cases (UCs) - 2



## Ericsson Cell Free Radio Stripes Use Cases (UCs) - 2



## Sparse Deployment of Access Points

Tower



Sensitive to blocking

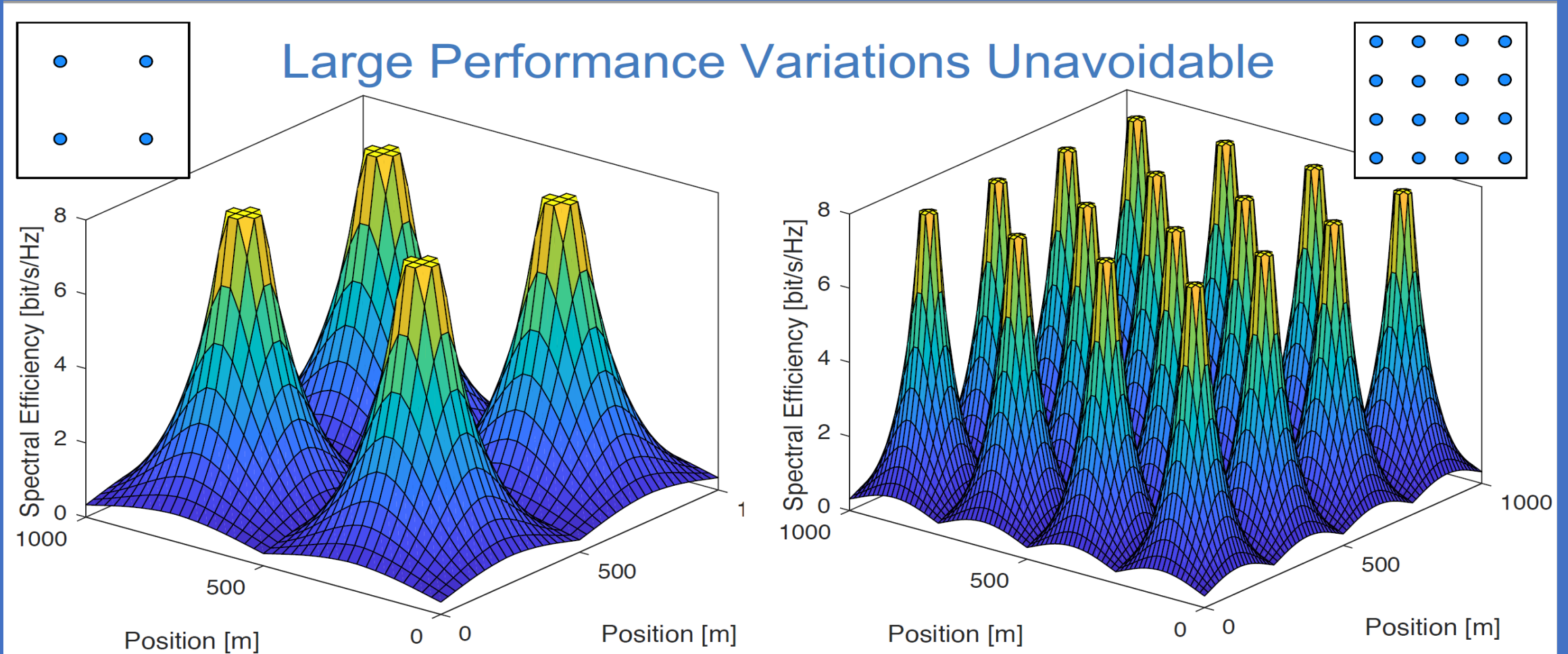
Visible installation

Rooftop



Large variation in distance to users →  
Large signal strength variations

# Beyond the Cellular Paradigm: Cell-free Architecture with Radio Stripes



**Most users get mediocre performance**

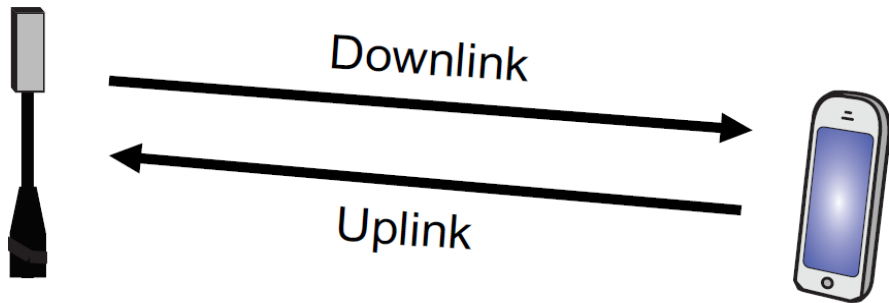
Enough for voice calls, not for data!

*Pathloss exponent: 3  
5-10 dB at cell edge*

# Efficient Channel Estimation – No Feedback is Needed!

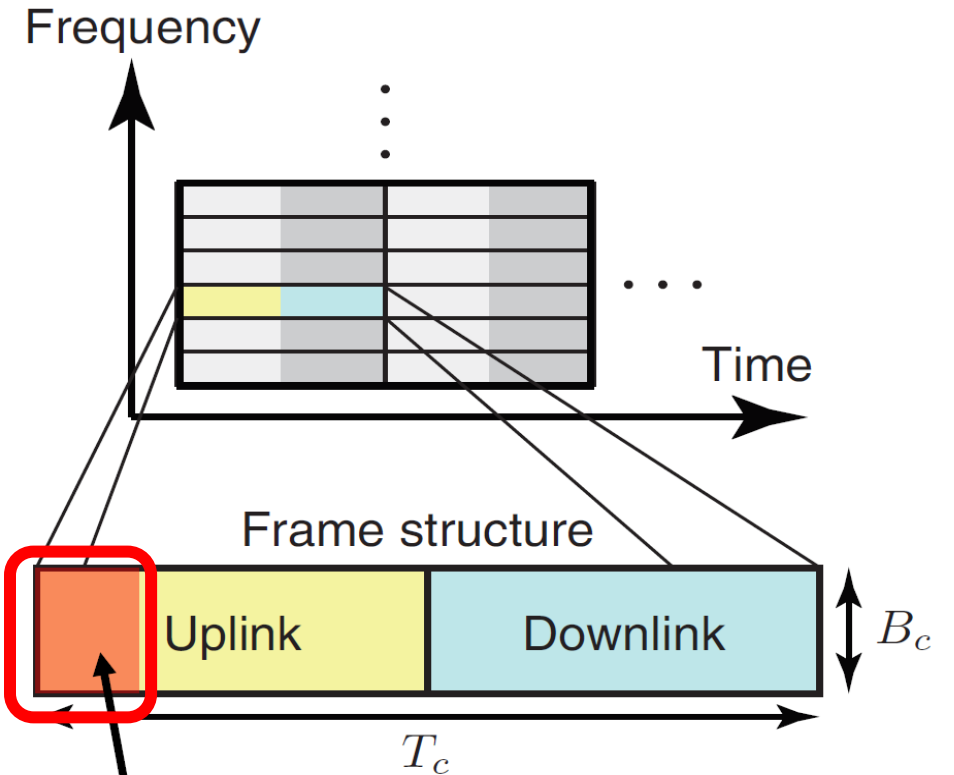
## Time-division duplex

Downlink and uplink on same frequency



Estimate channels at AP  
from uplink pilots

No need to share between APs



Pilots signals

The rest is used for data

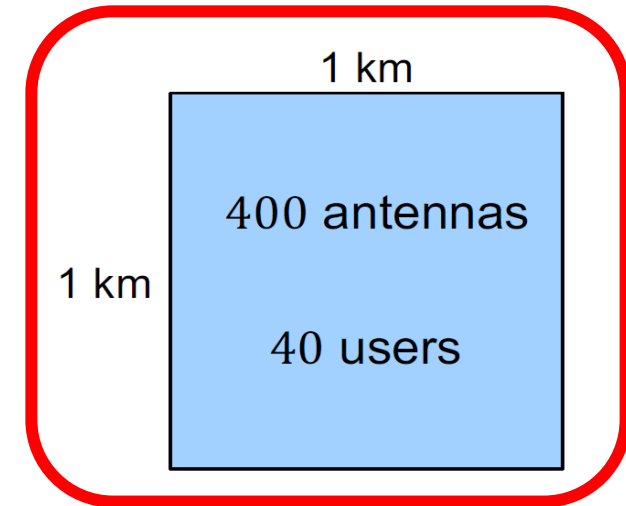
## Simulation Setup

- **Cell-free setups**

- 400 APs on a square grid
- Centralized or distributed processing

- **Cellular setups**

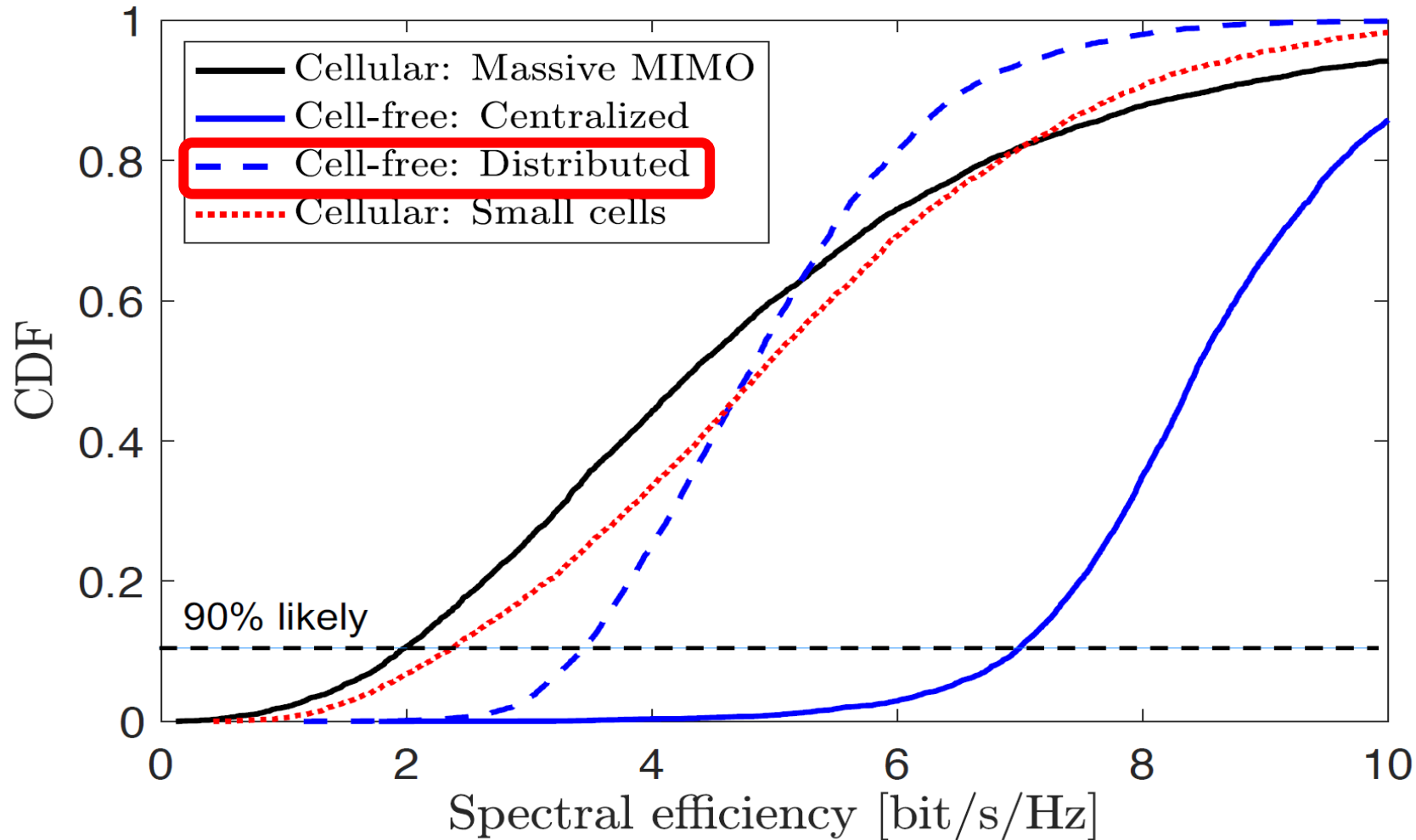
- Massive MIMO: 4 APs, 100 antennas each
- Small cells: Same AP locations in cell-free case



3GPP Urban Microcell model  
Uplink, 20 MHz, 100 mW power

**Reference:** E. Björnson, L. Sanguinetti, "Making Cell-Free Massive MIMO Competitive With MMSE Processing and Centralized Implementation," IEEE Trans. Wireless Communications, January 2020.

## Uplink Simulation Results



**Cell-free**  
Improves 90% likely performance

**Centralized version**  
Best performance

**Distributed version**  
Increases worst-case performance

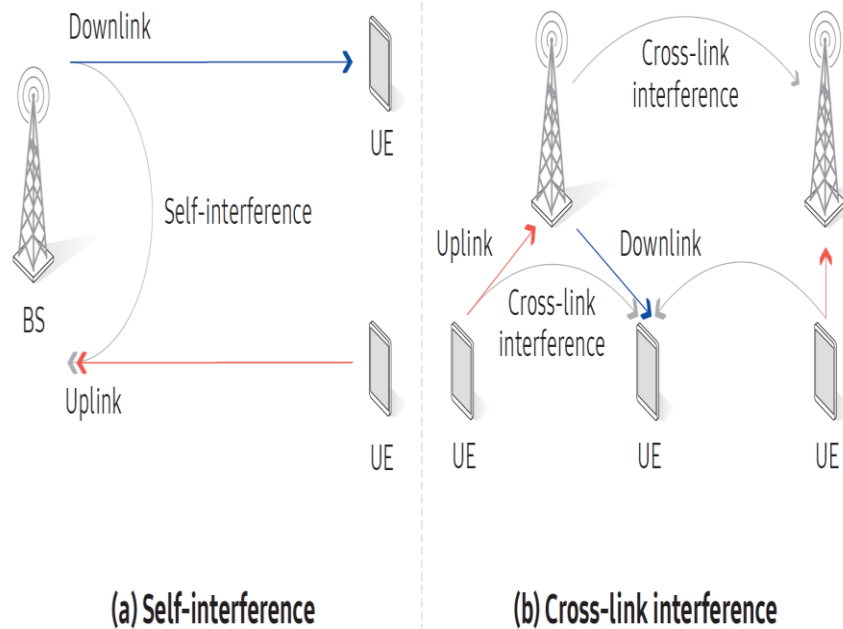
## Evolution of Duplex Technology (TDD, FDD, DSS)

In conventional communication systems, downlink and uplink transmissions occur in a mutually exclusive manner either in time domain (i.e., TDD) or in frequency domain (i.e., FDD). Typically, the downlink and uplink receive fixed allocations of time-frequency resources in practical systems. In 5G NR, dynamic TDD was introduced to improve the duplex flexibility, thus making it possible to adjust the ratio between downlink and uplink time slots depending on traffic demand. While this is an improvement over earlier generations, there is still active research [29][30][31] into how to remove the restriction that downlink and uplink must use mutually exclusive time-frequency resources. We refer to this restriction as the “mutually exclusive” principle hereafter.

Allowing overlap between DownLink and UpLink over the entire time-frequency resource (a.k.a. “Full Duplex”) can increase system capacity by two (2) times, in theory. The main obstacles encountered upon deviating from the “mutually exclusive” principle include Self-Interference and Cross-link Interference. Self-Interference experienced by a BS Receiver is illustrated in Figure 14(a). The BS Transmits DownLink signal using the same Time-Frequency Resource as used for the UpLink Signal from UEs. Since the BS’s transmit and receive antennas are located in close proximity, self-interference is much stronger than the desired signals from the UEs. Therefore, to evolve duplex technology by departing from the “mutually exclusive” principle, it is crucial to be able to remove self-interference. There has been relevant research on self-interference cancellation (SIC) techniques, which typically require both analog and digital domain cancellation [32][33].

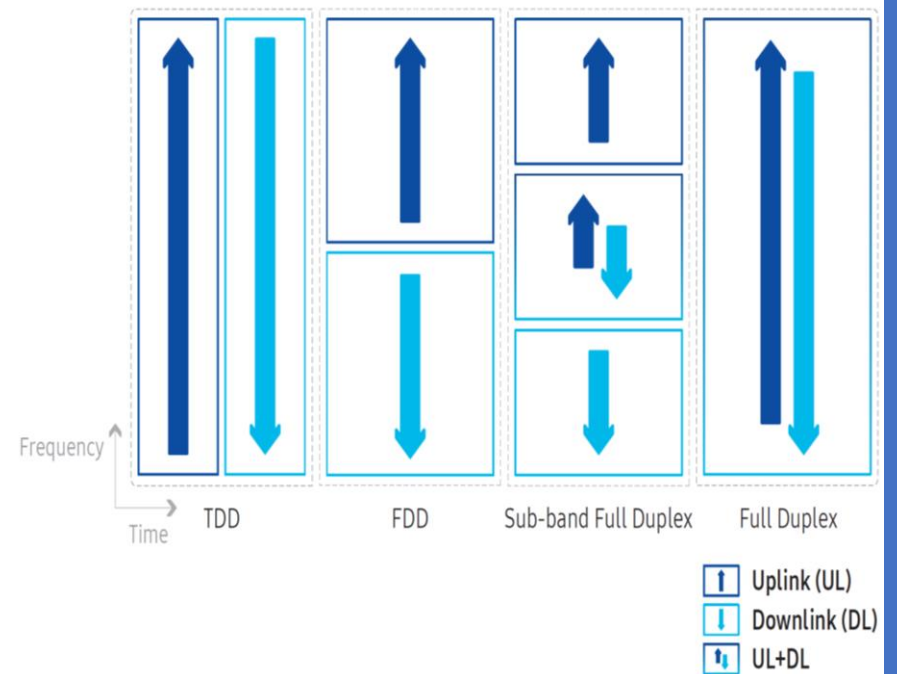
**Figure 14**

Main obstacles in deviating from the “mutually exclusive” principle.



**Figure 15**

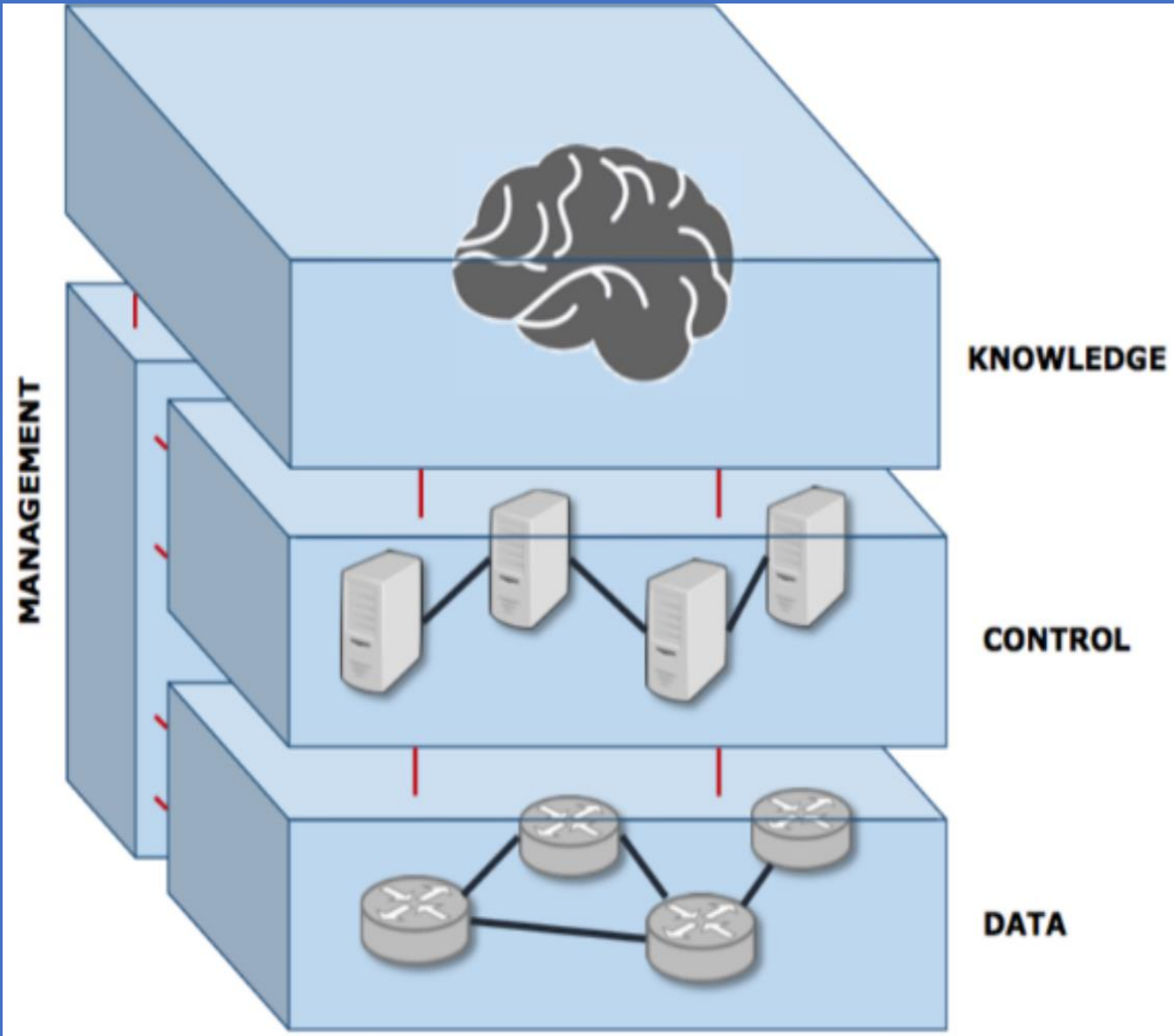
Dynamic operation of duplex modes.





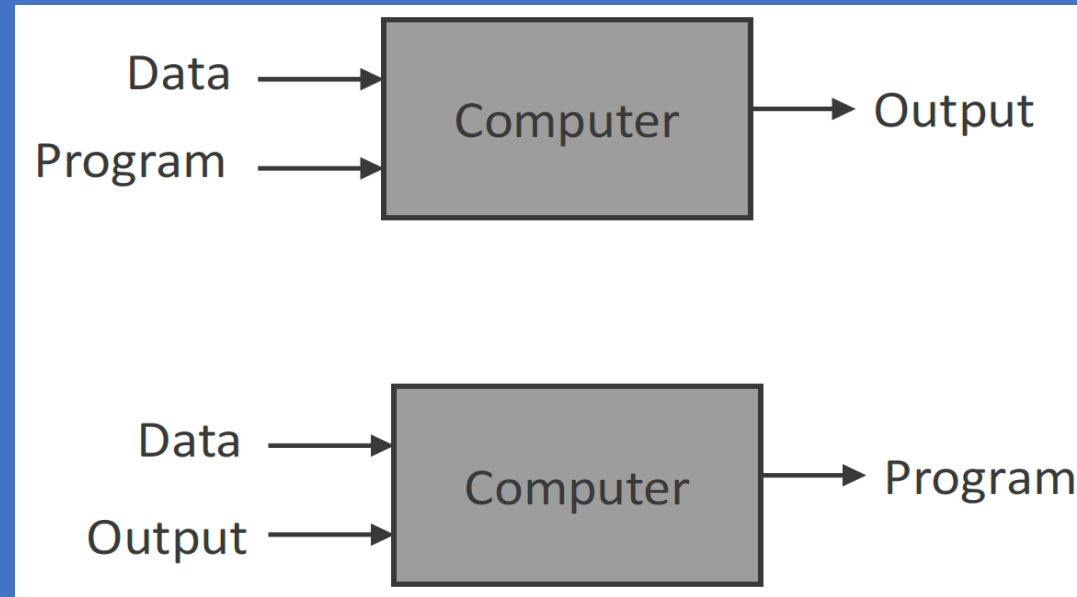
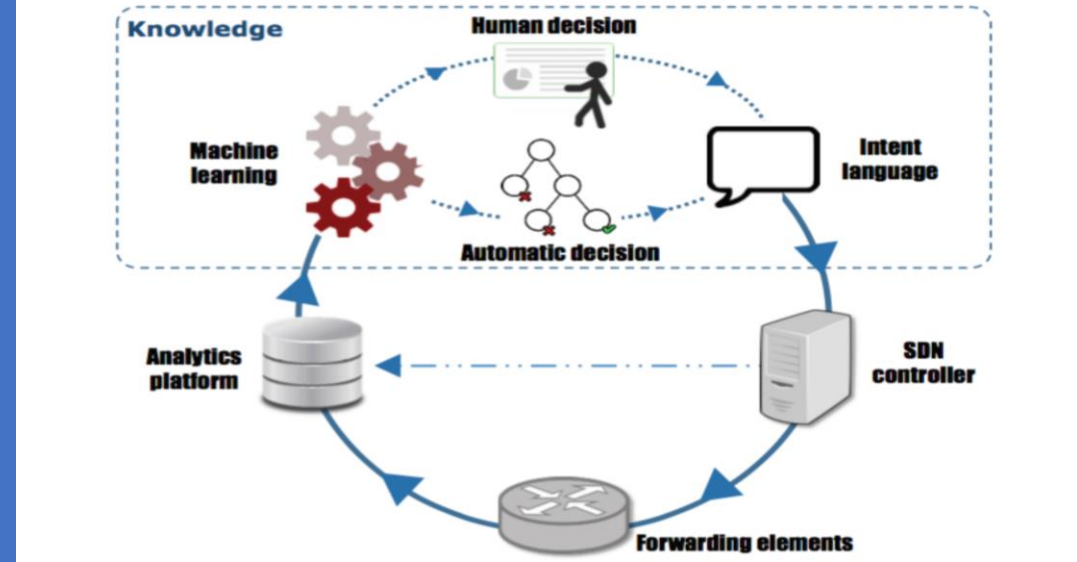
**Thank you**

# 1. KDN Knowledge Defined Network (KP)



TM Forum Knowledge Plane (KP)

A knowledge-defined network (KDN) operates by means of a control loop to provide automation, recommendation, optimization, validation and estimation.



# 1. KDN Knowledge Defined Network (KP)

## Distributed / Local / Fast decision-making element or “d\_DE” (per ODA Function Block) Design Principle

This Distributed Decision-making Logic with less complex Analytics for Autonomics / AI (Cognitive) Algorithms is realized by fast control loops located in each of the three ODA Function Bloc. This is reflected at the left-hand-side of Figure 7.7.

To be understood and used by any company, elco or not, and become a Standard, the ODA Framework must only describe invariant that are common to everybody. That is what this Functional Architecture provides.

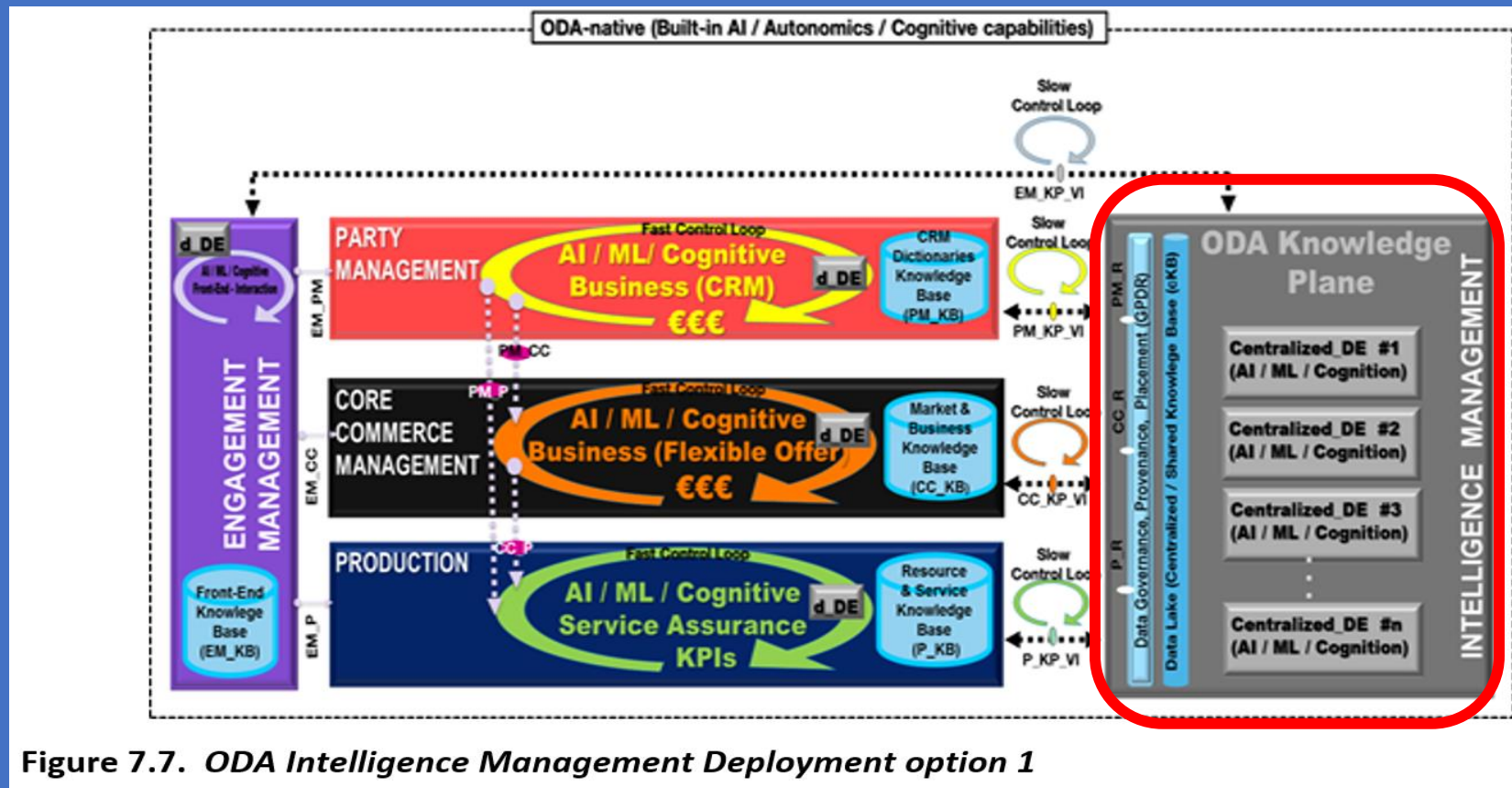


Figure 7.7. ODA Intelligence Management Deployment option 1

## ODA Knowledge Plane Federated model

The Three (3) ODA Knowledge Planes (KPs) are at the same level.

The Federation needs defining "East-West" Reference Points / Interfaces between those ODA Knowledge Planes

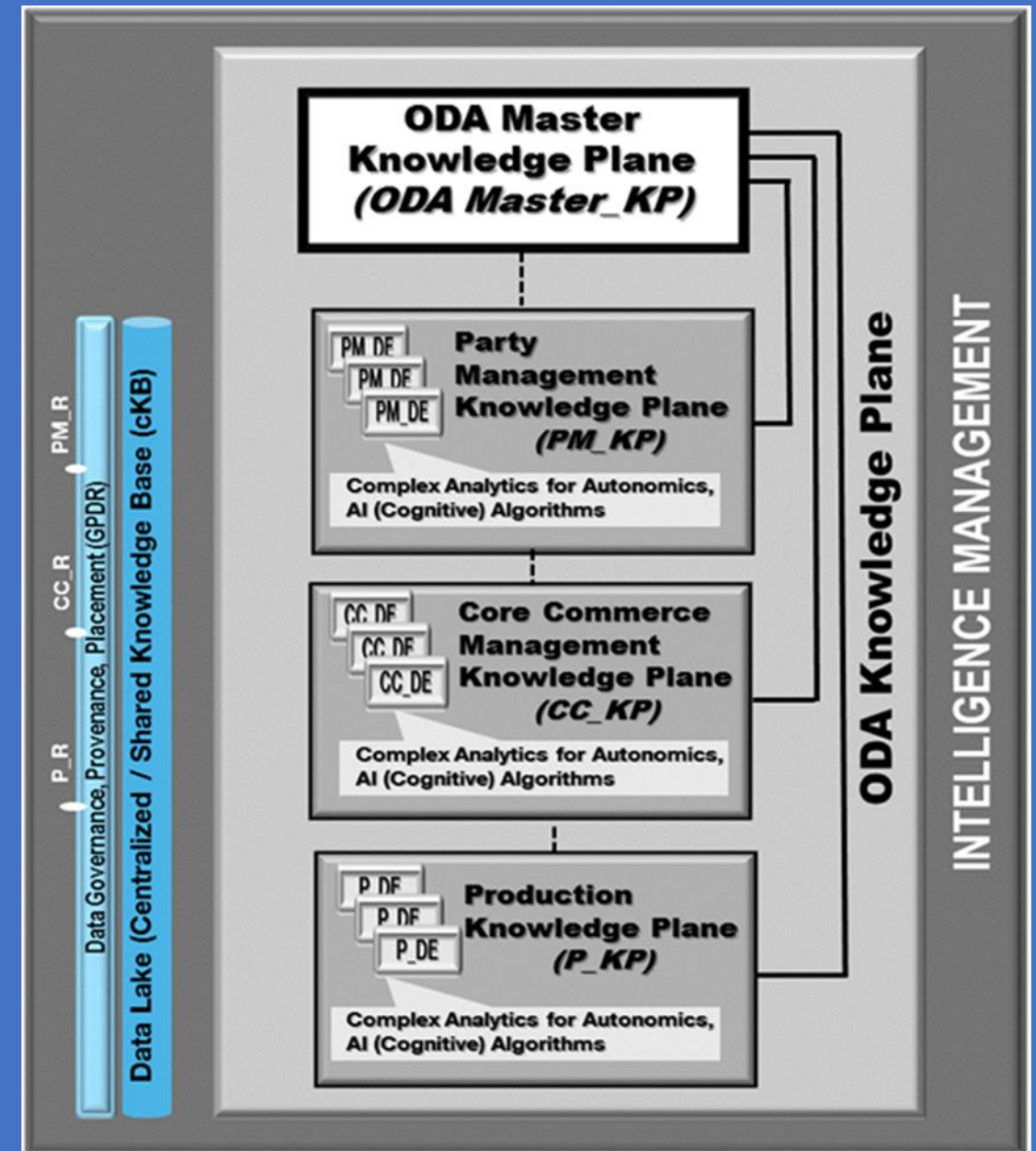


Figure 9.7. ODA Master Knowledge Plane (Hierarchy of Knowledge Planes)

# Factory Model - Orange

This Scenario represents the way Orange is setting up their Production area with their Factory Concepts.

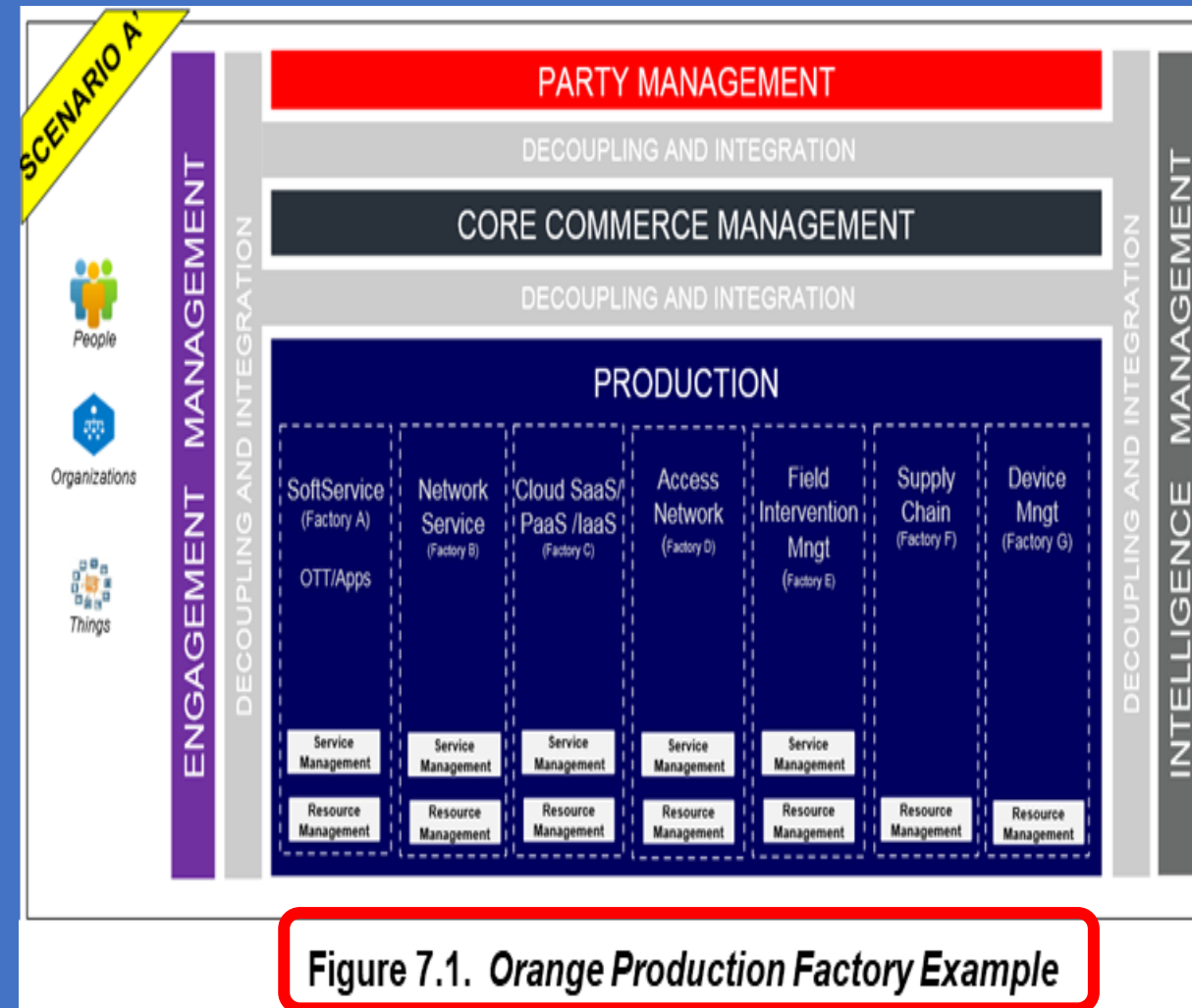
Most Factories are Autonomous and have their own Operational Domain(s) that exposes "Capabilities" as Customer Facing Services (CFS).

Most factories are exposing CFS.

Exception is for Devices and Physical goods, where Products cannot be restriction of CFS, so these Factories do not expose CFS.

Therefore, Service Management is not required for "Supply Chain" and "Device" factories.

Also, note the "Access Network" factory is separate from the "SoftService" factory to have the Capability to deliver Softservices without any dependency on Access.

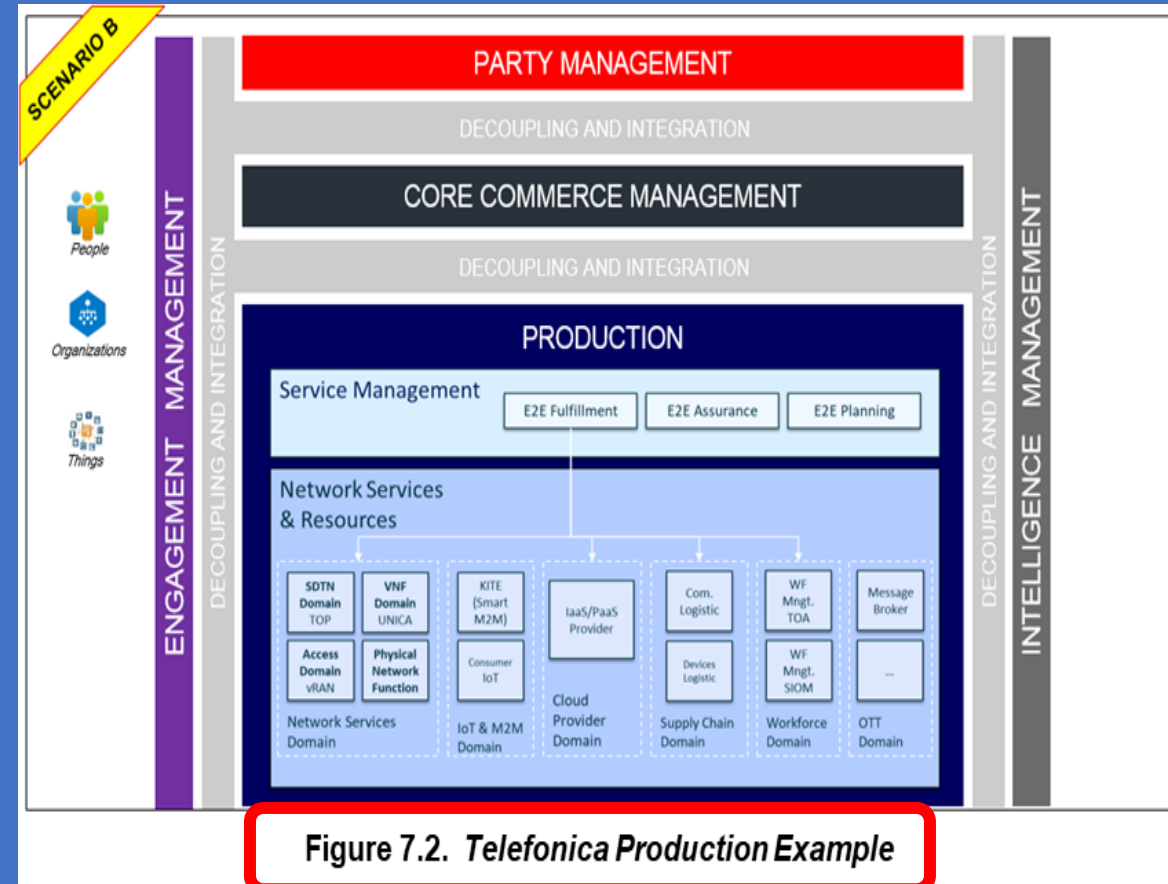


## E2E Service Model – Telefonica

Telefonica continues to have a “Service Management” Layer to handle the technical order through the different domains, proving an end to end control of the different processes (Fulfillment, Assurance and Planning)

Benefits of this proposed deployment approach:

- A single E2E view across all Resource Domains is maintained.
- Reduces Service Management activity duplication
- Implements a single point of Service design irrespective of the Resource domain.
- Service is agnostic of the underlying Resources



## NaaS Model – Telstra with Operational Domain Management (ODMs)

Telstra Networks expose Network as Services (NaaS) grouped by similar functions and/or by organizational level.

Every Operational Domain Management (ODM) would be responsible for the entire lifecycle of the services it exposes including the management of resources.

Some ODM may be responsible for services that are coordinated across other ODMs and hence would not manage the resources directly.

NaaS API component suite is used as the contract of operational functions supported between the Core Commerce Management Block and ODMs as well as between ODM to ODM.

Benefits of this proposed deployment approach

- Expose the network as a service.
- Reduce network management complexity

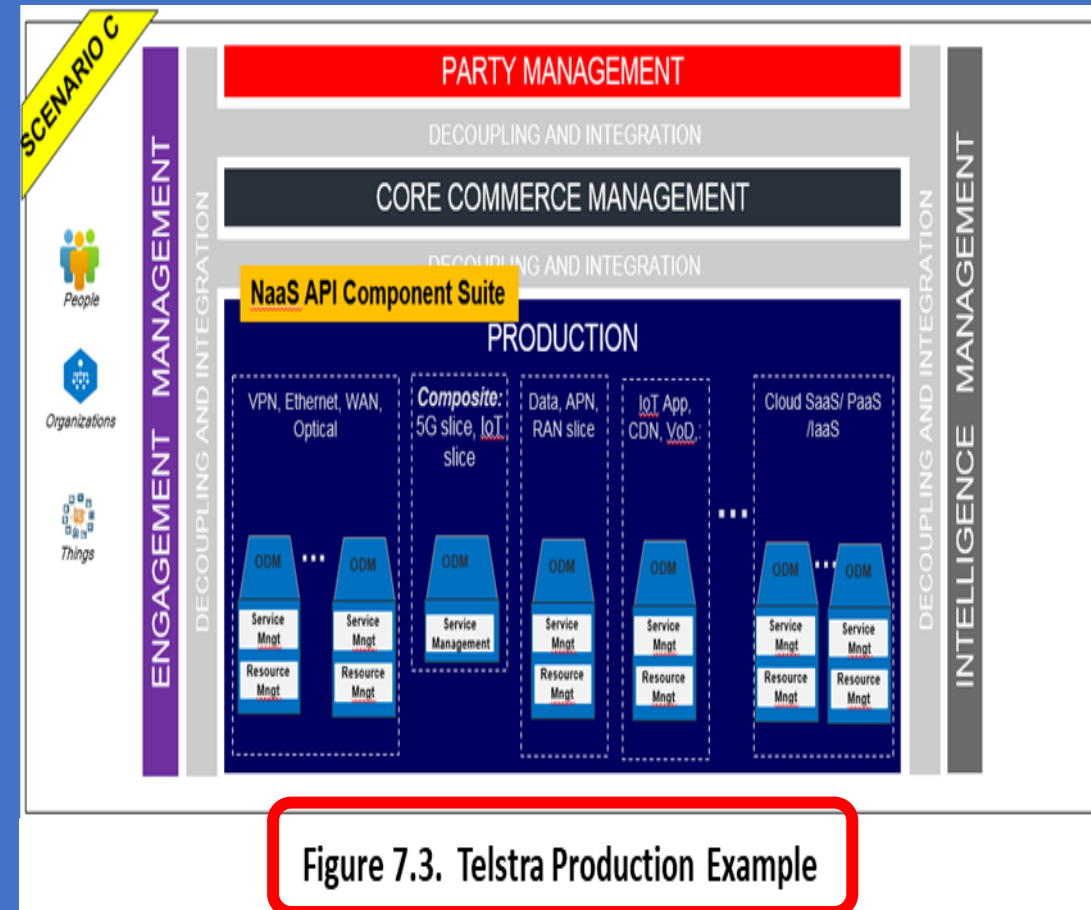


Figure 7.3. Telstra Production Example