

# **5G System and Service Providers (SP)**

**New Services**

**Data-centric approach**

**to**

**LF Edge Akraino**

**API TSC Sub-committee**

**Ike Alisson**

**LF Edge Akraino Documentation Sub-committee**

**TSC Chair**

**2021-02-19 Rev PA10**



## Table of Contents

1. Introduction - key 2 questions for differentiating Data-centric approach
2. APIs - Declarative Approach and YAML
3. 5GS NFs as "Consumer and Producer"
4. 5G NDL Network data Layer for Structured and Unstructured Data (Context)
5. IoT SL Platform with Advanced Semantic Discovery (ASD)
6. Commercial aspects
7. Summary





# Introduction

## Two (2) Questions on APIs & Data-centric Platforms/Systems/Solutions

Nr. 1 Functional Process - **HOW?**

Nr. 2 Purpose / Intent - **WHAT?**

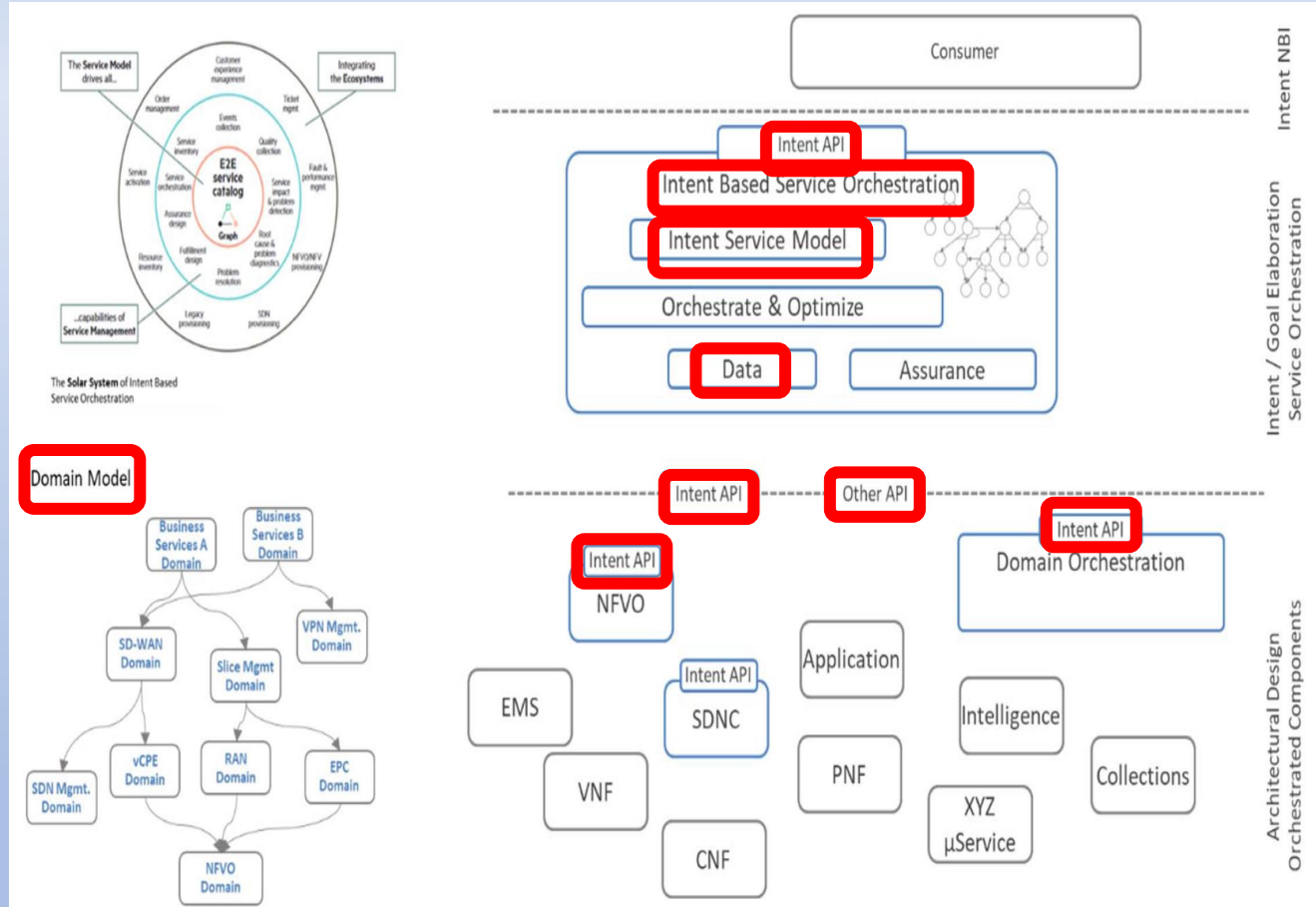

Figure 10: Intent-based Service Orchestration across Domains, driven by Intent-based Service Models



Two (2) Questions on APIs:

Nr. 1 APIs: Type and Functions

-

**HOW?**

**APIs**



# 1. Declarative APIs & YAML - 1



Filmed at  
**QCon** San Francisco 2019

Brought to you by  
**InfoQ**

DECLARATIVE APIS,  
**IMPERATIVE WORLD**  
BY TILDE THURIUM (THEY/THEM)



DECLARATIVE PROGRAMMING IS:

**PROGRAMMING THAT IS DONE WITH DECLARATIONS, RATHER THAN STATEMENTS**

Filmed at  
**QCon** San Francisco 2019

Brought to you by  
**InfoQ**



DECLARATIVE PROGRAMMING:

**EXPRESSES THE LOGIC OF A COMPUTATION WITHOUT DESCRIBING ITS CONTROL FLOW**

Filmed at  
**QCon** San Francisco 2019

Brought to you by  
**InfoQ**

# 1. Declarative APIs & YAML - 2

## 1. Imperative

From Hyatt Regency San Francisco, 5 Embarcadero Center, San Francisco, CA 94111 to Exploratorium, Pier 15, The Embarcadero, San Francisco, CA 94111

3 min (0.6 mile)  
via Drumm St and The Embarcadero  
Fastest route, despite the usual traffic

**IMPERATIVE AF**

Hyatt Regency San Francisco  
5 Embarcadero Center, San Francisco, CA 94111

- Head south on Drumm St
- 0.0 mi
- Turn right onto The Embarcadero
- 0.2 mi
- Turn right onto Washington St
- 0.2 mi
- Turn left onto The Embarcadero
- 0.4 mi

Exploratorium  
Pier 15, The Embarcadero, San Francisco, CA 94111

Filmed at QCon San Francisco 2019  
Brought to you by InfoQ

## 2. Declarative

PIER 15, SFO CA 94111

Filmed at QCon San Francisco 2019  
Brought to you by InfoQ

## 3. All Declarative Approaches have Imperative Implementation

ALL DECLARATIVE APPROACHES  
HAVE AN UNDERLYING  
IMPERATIVE IMPLEMENTATION

Filmed at QCon San Francisco 2019  
Brought to you by InfoQ

# 1. Declarative APIs & YAML - 4

## Declarative Kubernetes Lifecycle Management with Kubernetes Cluster API v1alpha1

### Kubernetes Declarative API

### Cluster API is a Declarative API Specification.

Cluster API is the API Specification that helps provide **Uniform and Consistent Management for Kubernetes Clusters** regardless of the underlying Infrastructure.

For v1alpha1, the API comprises 5 Custom Resource Definitions (CRDs):

1. Cluster,
2. Machine,
3. Machine Set,
4. Machine Deployment, and
5. Machine Class. Kubernetes



# Declarative APIs & YAML - 3

1. The Non-RT RIC is deployed in a **Service Management & Orchestration Framework (SMO)** & provides **Declarative Policy Guidance** for Cell-level Optimization by providing the optimal configuration values for cell parameters over the O1 Interface.

2. The Non-RT RIC also **sends Declarative Policies** for UE-level optimization to the Near-RT RIC via the A1 interface.

3. The Near-RT RIC then translates the recommended **Declarative Policy** from the Non-RT RIC over A1 interface into per-UE Control and **imperative policy over the E2 interface**.

4. The Non-RT RIC develops **ML/AI-driven Models** for Policy Guidance and non-RT Optimization as rApp Microservices.

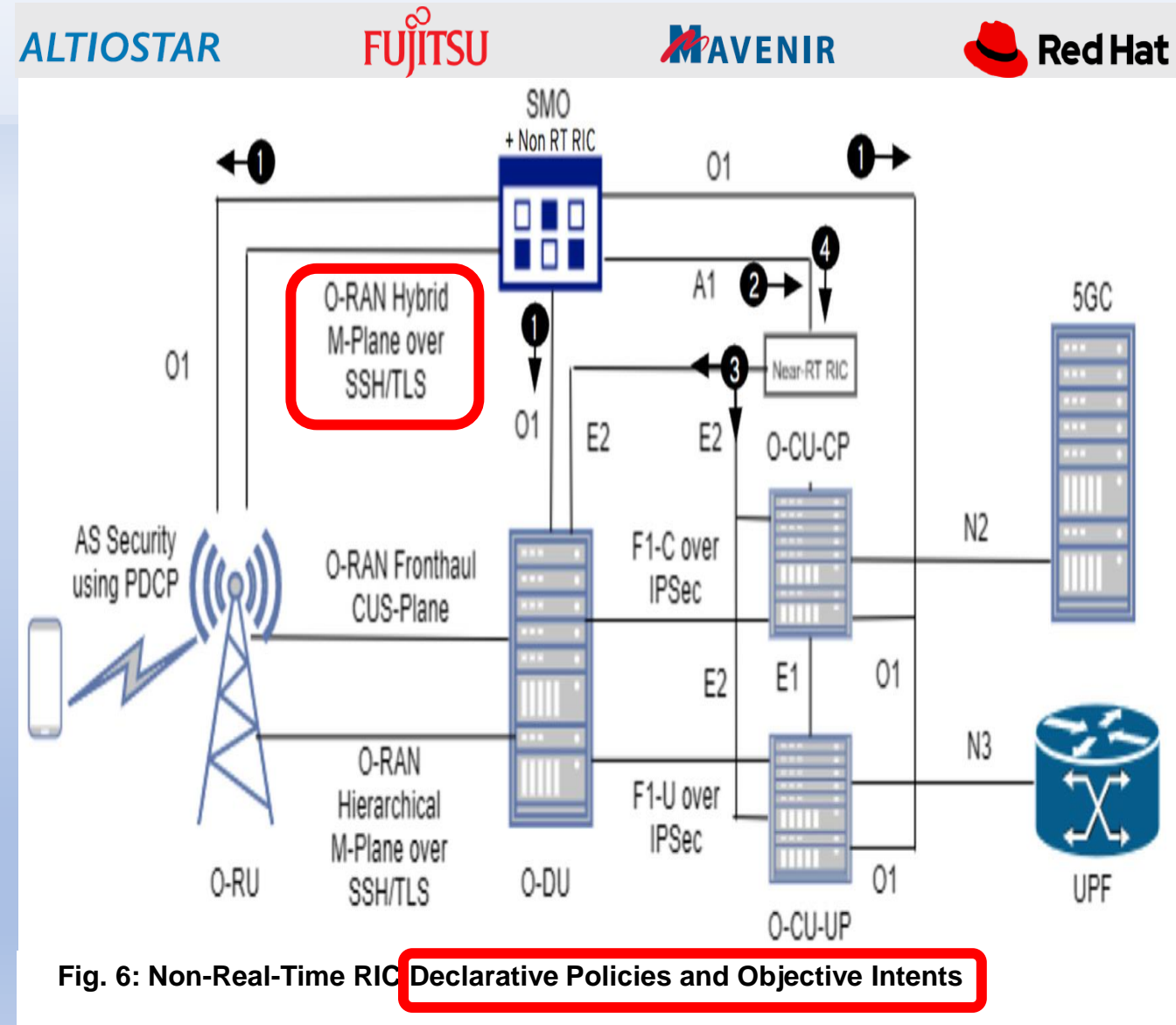

# 1. Declarative APIs & YAML - 4a

The OS Virtualisation Technology allows partially shared execution Context for different Containers. Such a shared Execution Context is frequently referred to as a Container Pod.

In addition to Hypervisor-based Execution Environments that offer HW Abstraction & Thread Emulation

Services, **the OS Container Execution Environment provides Kernel Services that include:**

- 1. Process Control.** EXAMPLE 1: OS process creation; scheduling; wait and signal events; termination.
- 2. Memory Management.** EXAMPLE 2: Allocation and release of regular and large pages; handling memory- mapped objects and shared memory objects.
- 3. File System Management.** EXAMPLE 3: Creation, removal, open, close, read and write file objects.
- 4. Device Management.** EXAMPLE 4: Request, release, configuration and access.
- 5. Communication Services.** EXAMPLE 5: *Protocol Stack Services*, Channel Establishment and Release, PDU Transmission and Reception.
- 6. System Information Maintenance.** EXAMPLE 6: Time and date, system and OS Resource Data, performance and fault indicators.

**OS Virtualisation provides Storage Abstraction on File System Level rather than on Block Device Level.**

Each container has its separate file system view, where the guest file system is typically separated from the host file system. Containers within the same pod might share file systems where modifications made in one container are visible in the others.

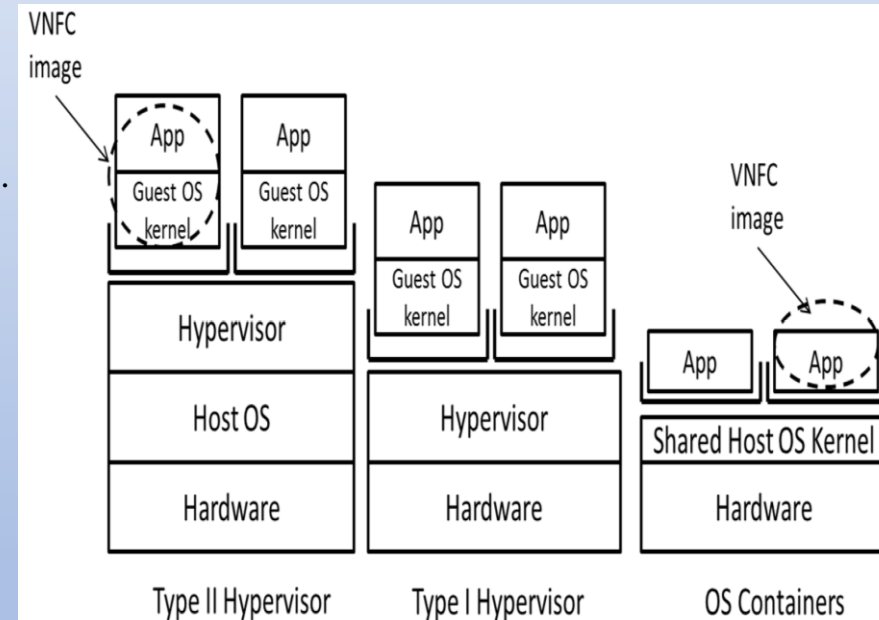
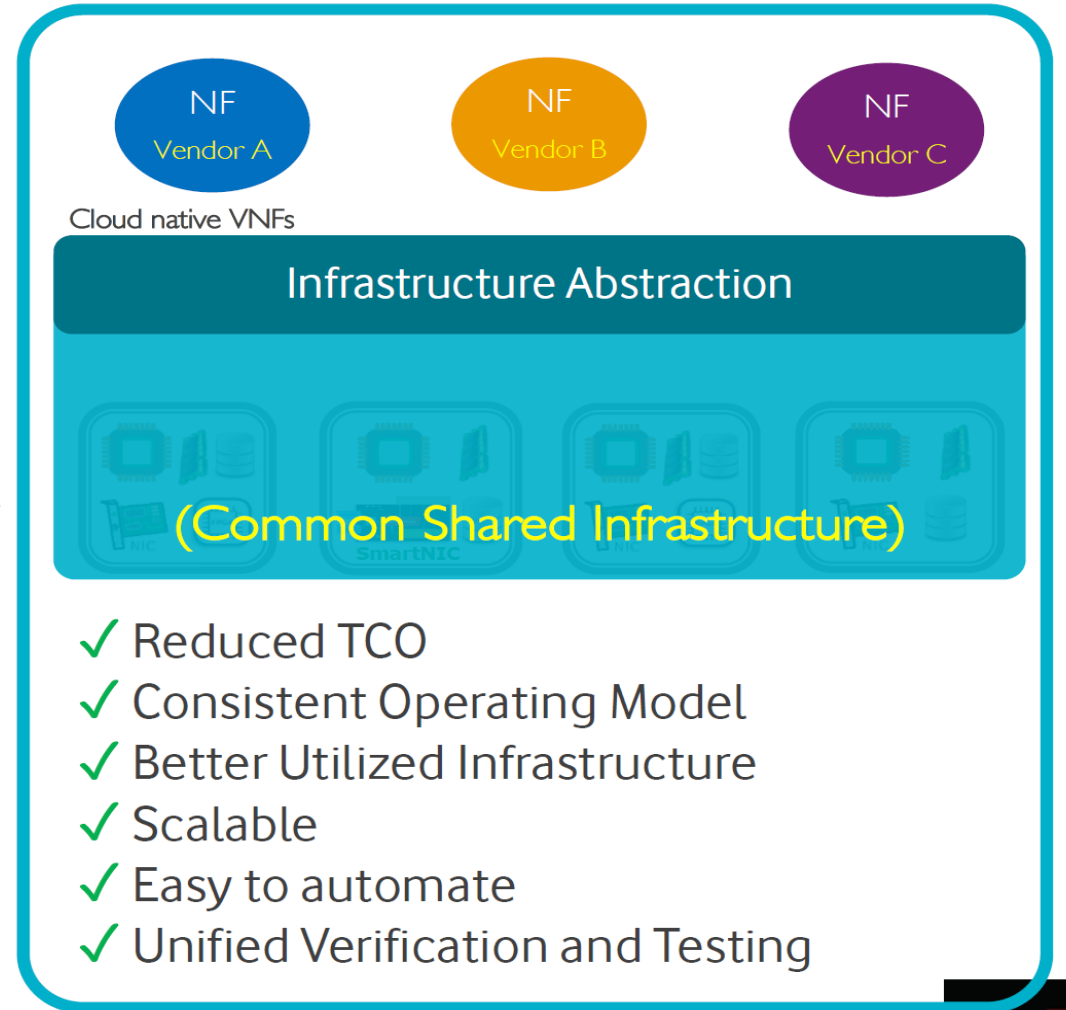
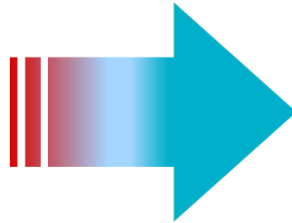
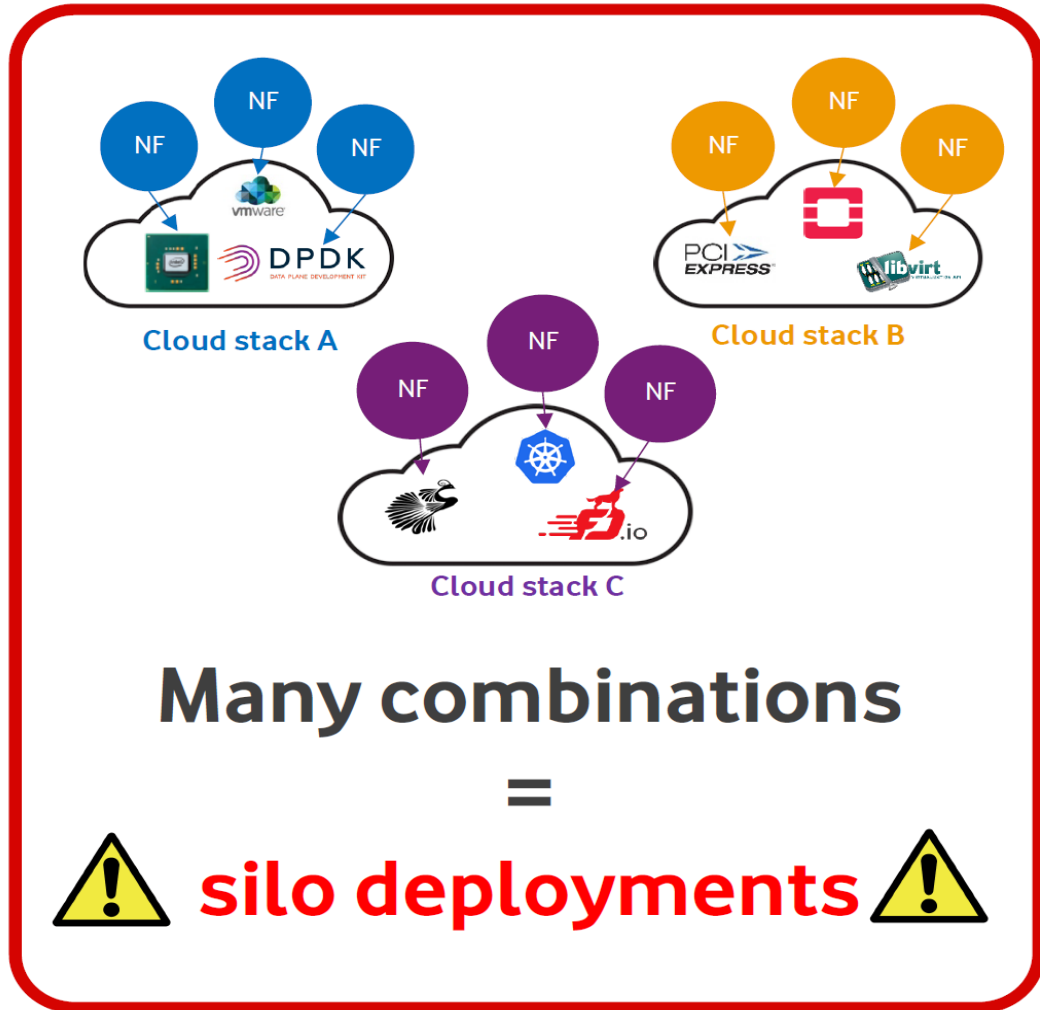

Figure 1: Hypervisor vs. OS Container solutions



# 1. Declarative APIs & YAML - 4b

## Anuket | Problem Statement



# 1. Declarative APIs & YAML - 5

ETSI **GS MEC 009** V2.2.1 (2020-10)



**Multi-access Edge Computing (MEC);  
General principles, patterns and common aspects  
of MEC Service APIs**

## 5.3 Provision of an OpenAPI definition

An ETSI ISG MEC GS defining a RESTful MEC service API should provide a supplementary description file (or supplementary description files) compliant to the OpenAPI specification [i.14], which inherently include(s) a definition of the data structures of the API in JSON schema or YAML format. A description file is machine readable facilitating content validation and autocreation of stubs for both the service client and server. A link to the specific repository containing the file(s) shall be provided. All API repositories can be accessed from <https://forge.etsi.org>. The file (or files) shall be informative. In case of a discrepancy between supplementary description file(s) and the underlying specification, the underlying specification shall take precedence.

## 5.4 Documentation of the API data model

### 5.4.1 Overview

Clause 5.4 and its clauses specify provisions for API data model documentation for ETSI ISG MEC GSs defining RESTful MEC service APIs. Clause 5 in annex D provides a related data model template.

The data model shall be defined using a tabular format as described in the following clauses. The name of the data type shall be documented appropriately in the heading of the clause and in the caption of the table, preferably as defined in clause 5.2.2 and in annex D.



# 1. Declarative APIs & YAML - 7

## What is APIs YAML: Machine Readable Specification

YAML 1.2 is a superset of JSON (JavaScript Object Notation) with [some built-in advantages](#), e.g.

YAML can

- Self-reference,
- **Support Complex Datatypes,**
- Embed Block Literals,
- Support comments, and more.

**YAML tends to be more readable than JSON.**

The logo for APIs.yaml, featuring a stylized icon of a person or figure to the left of the text "APIs.yaml".

What is APIs.yaml?

APIs.yaml is a machine readable specification that API providers can use to describe their API operations, similar to how web sites are described using sitemap.xml. Providing an index of internal, partner, and public APIs, which includes not just the the OpenAPI, JSON Schema, and other machine readable artifacts, but also the currently only human readable elements like documentation, pricing, and terms of service.

# 1. Declarative APIs & YAML - 8

## OpenAPI Specification

Version 3.0.3



### 4.2 Format

An OpenAPI document that conforms to the OpenAPI Specification is itself a JSON object, which may be represented either in JSON or YAML format.

In order to preserve the ability to round-trip between YAML and JSON formats, YAML version [1.2](#) is *RECOMMENDED* along with some additional constraints.

**Note:** While APIs may be defined by OpenAPI documents in either YAML or JSON format, the API request and response bodies and other content are not required to be JSON or YAML.



Why Swagger? ▾ Tools ▾ Resources ▾

## OpenAPI Specification

Version 3.0.3

### Format

An OpenAPI document that conforms to the OpenAPI Specification is itself a JSON object, which may be represented either in JSON or YAML format.

In order to preserve the ability to round-trip between YAML and JSON formats, YAML version [1.2](#) is *RECOMMENDED* along with some additional constraints.

**Note:** While APIs may be defined by OpenAPI documents in either YAML or JSON format, the API request and response bodies and other content are not required to be JSON or YAML.

# Access Context Manager documentation

- Overview
- Training and tutorials

Access Context Manager allows enterprises to configure access levels which map to a policy defined on request attributes. [Learn more](#)

- ### Guides
- Quickstart
  - Creating a basic access level
  - Managing access levels
  - IAM Roles for Administering Access Context Manager
  - Creating an access policy

- ### Reference
- Access level attributes
    - Example YAML for an access level
  - Custom access level specification
    - REST API
    - RPC API

- ### Resources
- Quotas and limits
  - Release Notes
  - Pricing

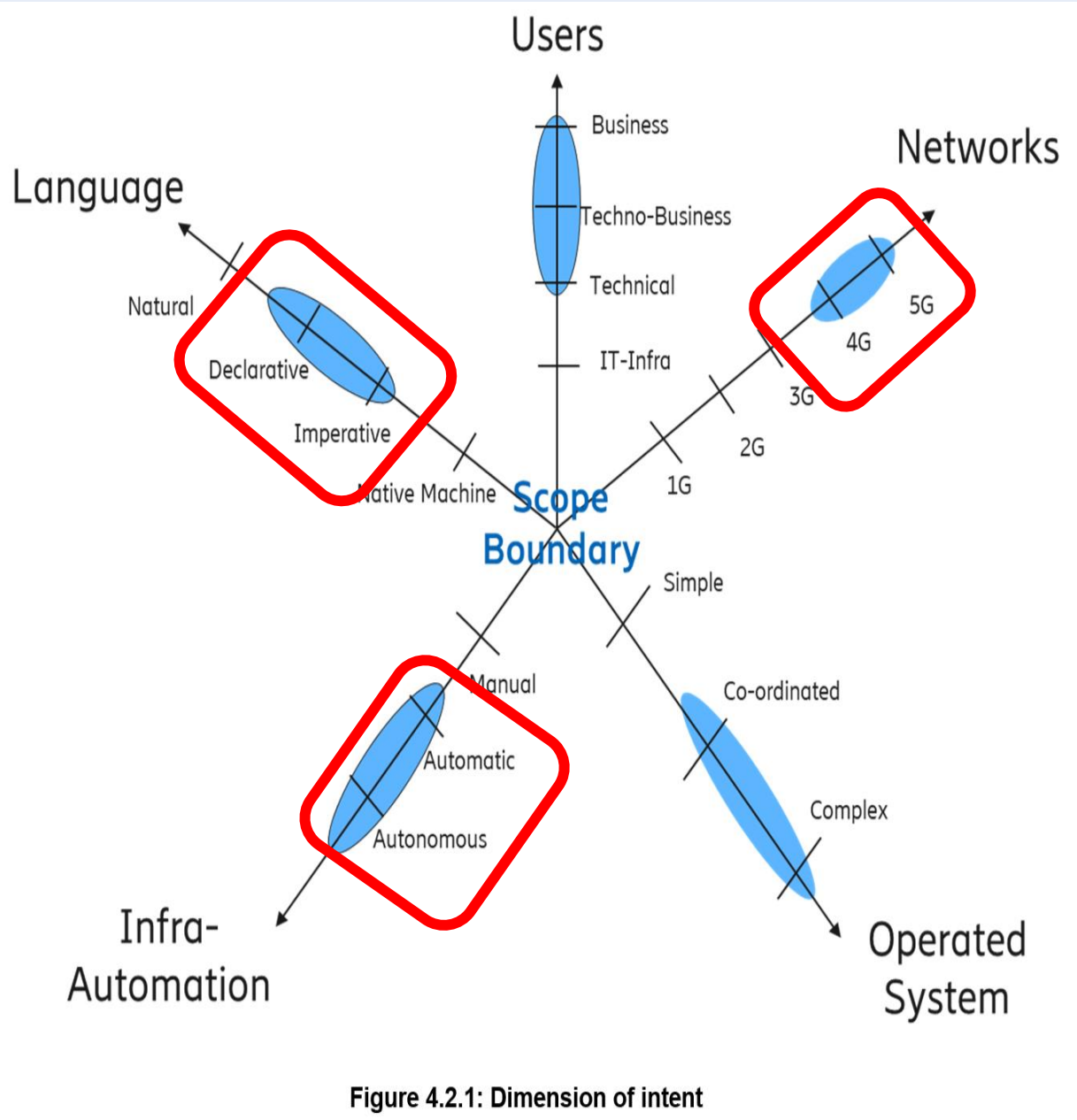

Figure 4.2.1: Dimension of intent

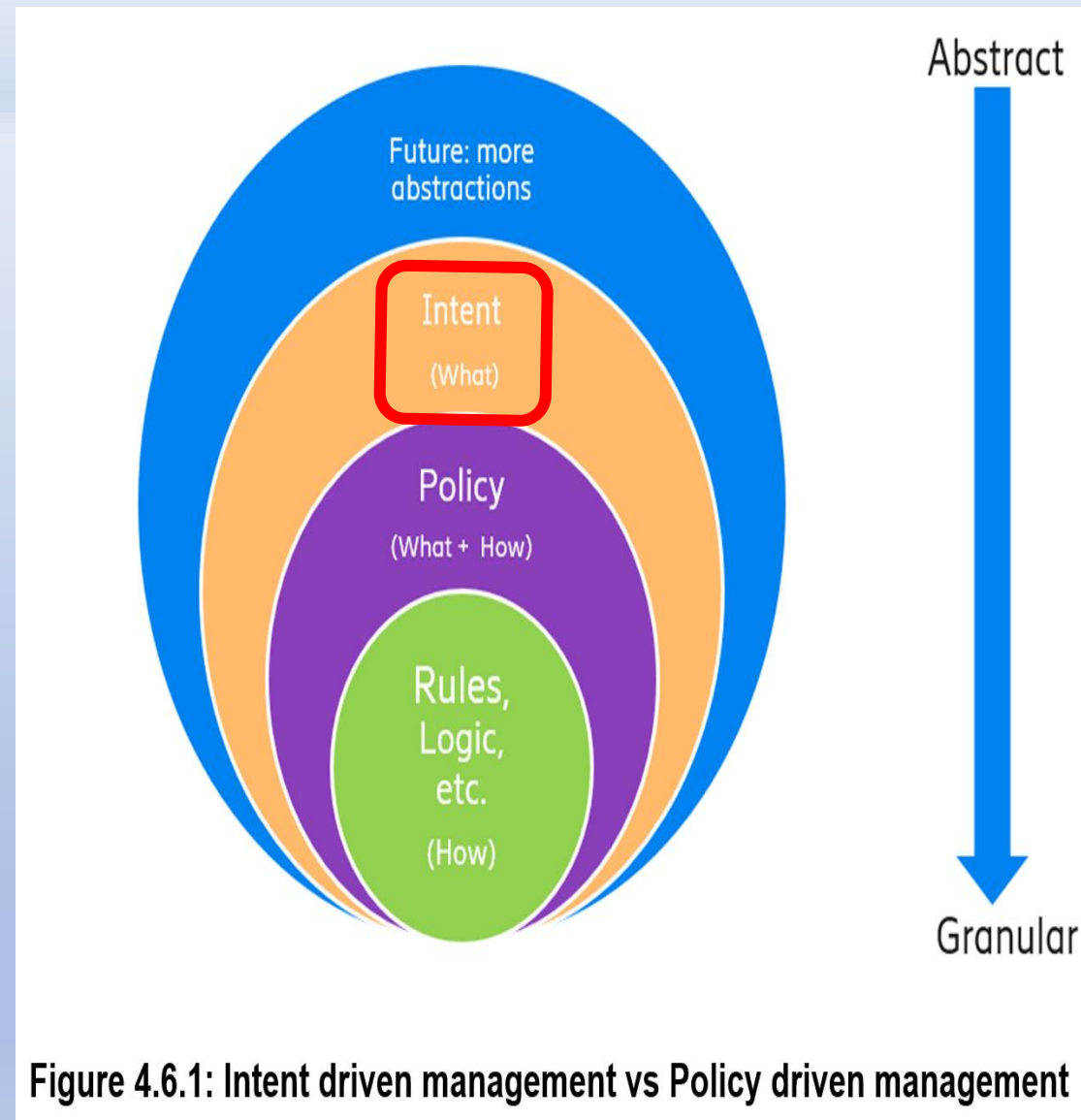

Figure 4.6.1: Intent driven management vs Policy driven management

# Use of the Policy Continuum

**Declarative Policies** are used in the service, administrator, and device views, since they enable logic programs to express and act on Goals that are applicable to the needs of these actors:

Declarative policies are likely not applicable to the instance view, since that would require a device that could evaluate declarative logic.

Declarative policies could, of course, be used in the Business view. However, Declarative policies use formal logic, which is difficult for business actors to use.

**Imperative Policies** are used in the Service, administrator, device, and instance views, since they enable actors to specify a Policy using a simple syntax:

Imperative policies could, of course, be used in the business view. However, Intent policies are judged to be easier to use.

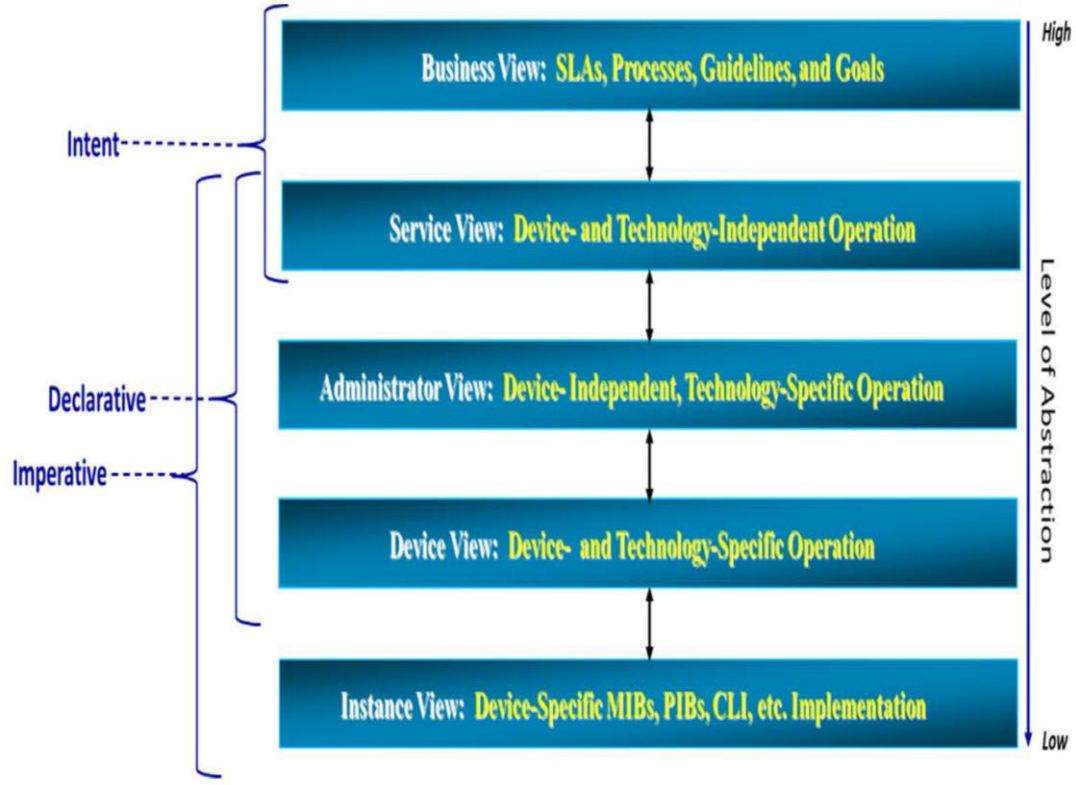

Figure 5.1-1: Mapping Actors to Different Policy Paradigms



# ONAP CNF Journey (REQ-341)

Prepared by Lukasz Rajewski (Orange), Seshu Kumar (Huawei)



## Completed

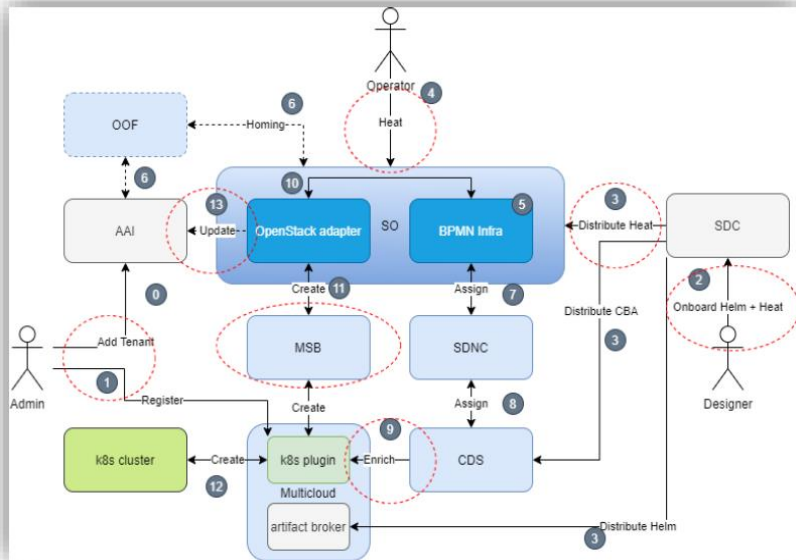

## On-Going

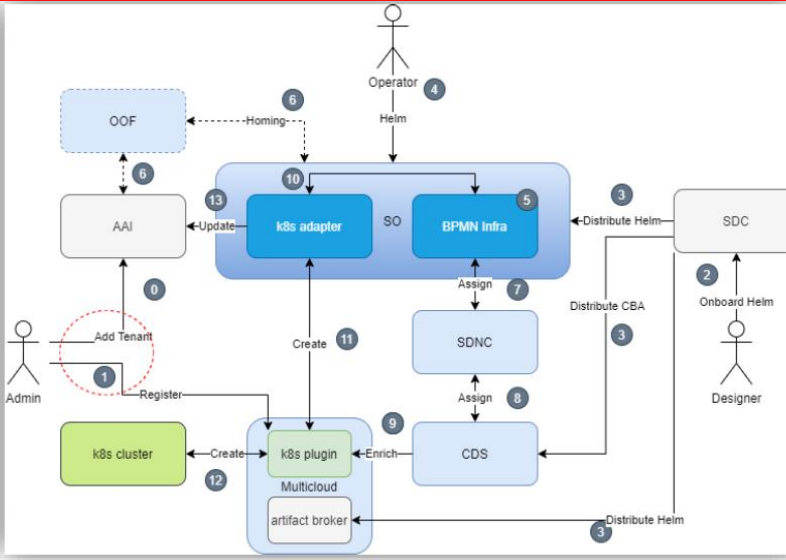

## Expected



### Till Frankfurt

- ✓ Embedding the Helm into the Heat package distro
- ✓ CLOUD\_TECHNOLOGY\_SPECIFIC artifact distributes Helm
- ✓ Installation of Helm package(s) into K8s cluster
- ✓ Basic Helm enrichment through CDS - Introduced

### Guilin Brings

- ✓ HELM artifact is Introduced to make Helm charts a first class citizen
- ✓ HELM artifacts supported in Day 0 and Day 1
- ✓ Native Helm support in E2E Orchestration
- ✓ Enhanced native Helm enrichment through CDS, K8s Plugin interactions.

### Beyond

- ✓ Cross community Integration and SDO Compliance
- ✓ Extension to CNF model with Health Check and Monitoring of CNF resources
- ✓ Auto discovery of K8S cluster in ONAP
- ✓ Intent Driven orchestration and Service Control Loop Inc. CNFs



Release Requirements / REQ-329

# Guilin-R7 - Support for Intent-based Network

Clone++

Export ▾

## Details

|                    |                          |                |                                |
|--------------------|--------------------------|----------------|--------------------------------|
| Type:              | Epic                     | Status:        | <b>DONE</b>                    |
| Priority:          | High                     | Resolution:    | Done                           |
| Affects Version/s: | None                     | Fix Version/s: | <a href="#">Guilin Release</a> |
| Labels:            | None                     |                |                                |
| Epic Name:         | Intent-based Network     |                |                                |
| Requirement Type:  | Requirement (DEPRECATED) |                |                                |
| PoC:               | PoC                      |                |                                |
| TSC Priority:      | 4                        |                |                                |
| Arch Review:       | Not yet performed        |                |                                |
| Scope Status:      | Original Scope           |                |                                |
| T-Shirt Size:      | XL                       |                |                                |
| M1 Scorecard:      | Green                    |                |                                |
| M1 Approval:       | GO                       |                |                                |
| M2/3 Scorecard:    | Green                    |                |                                |
| M2/3 Approval:     | GO                       |                |                                |
| M4 Scorecard:      | Green                    |                |                                |
| M4 Approval:       | GO                       |                |                                |

## People

|           |                             |
|-----------|-----------------------------|
| Assignee: | Huang ZongHe                |
| Reporter: | Huang ZongHe                |
| Votes:    | 0 Vote for this issue       |
| Watchers: | 9 Start watching this issue |

## Dates

|           |                   |
|-----------|-------------------|
| Created:  | 20/May/20 2:29 AM |
| Updated:  | 06/Jan/21 8:56 AM |
| Resolved: | 02/Dec/20 8:32 AM |



# MEF and TM Forum Collaborate on Open APIs for Service Automation

Share: [in](#) [twitter](#) [email](#)

## Media Contact:

Ashley Schulte  
Connect2 Communications for MEF  
[MEF@connect2comm.com](mailto:MEF@connect2comm.com)

*MEF and TM Forum align to bring consistency and ease-of-use to standardized APIs for inter-provider services*

**Los Angeles, 7 October 2020** – [MEF](#) and [TM Forum](#) have completed initial efforts to ensure that both organizations are aligned to use open standard APIs to automate inter-provider services for digital transformation. This collaboration will help service providers accelerate their transition from operating within limited ecosystems/islands to being integral players in a worldwide federation of networks supporting on-demand digital services across multiple providers.

## TM Forum and MEF have specifically aligned on the following:

- TM Forum is developing Domain Context Specialization Guidelines that enable MEF LSO Sonata APIs to conform to TM Forum Open API standards.
- TM Forum API tooling is now being used by MEF to build the set of LSO Sonata APIs.
- LSO Sonata API product payloads work in alignment with TM Forum API standards using a polymorphic approach.
- The organizations have established a framework for ongoing collaboration.



# 1. "5G Network Mobility at "Cell" & "Cloud" Edge - NGMN WP Feb 2015 - 1

## Member Resources

Open Digital Framework

Open Digital Architecture ▾

Frameworkx ▾

Open APIs

Toolkits

Join the Project

## Open APIs



### Delivering business agility within companies and across digital ecosystems

TM Forum's suite of **50+ REST-based Open APIs** has been collaboratively developed to be used in a range of scenarios, internally enabling service providers to transform their IT and operational agility and customer centricity, while externally delivering a practical approach to seamless end-to-end management of complex digital services.

[Learn more about the program.](#)

Explore the Open APIs:



# 3GPP 5G

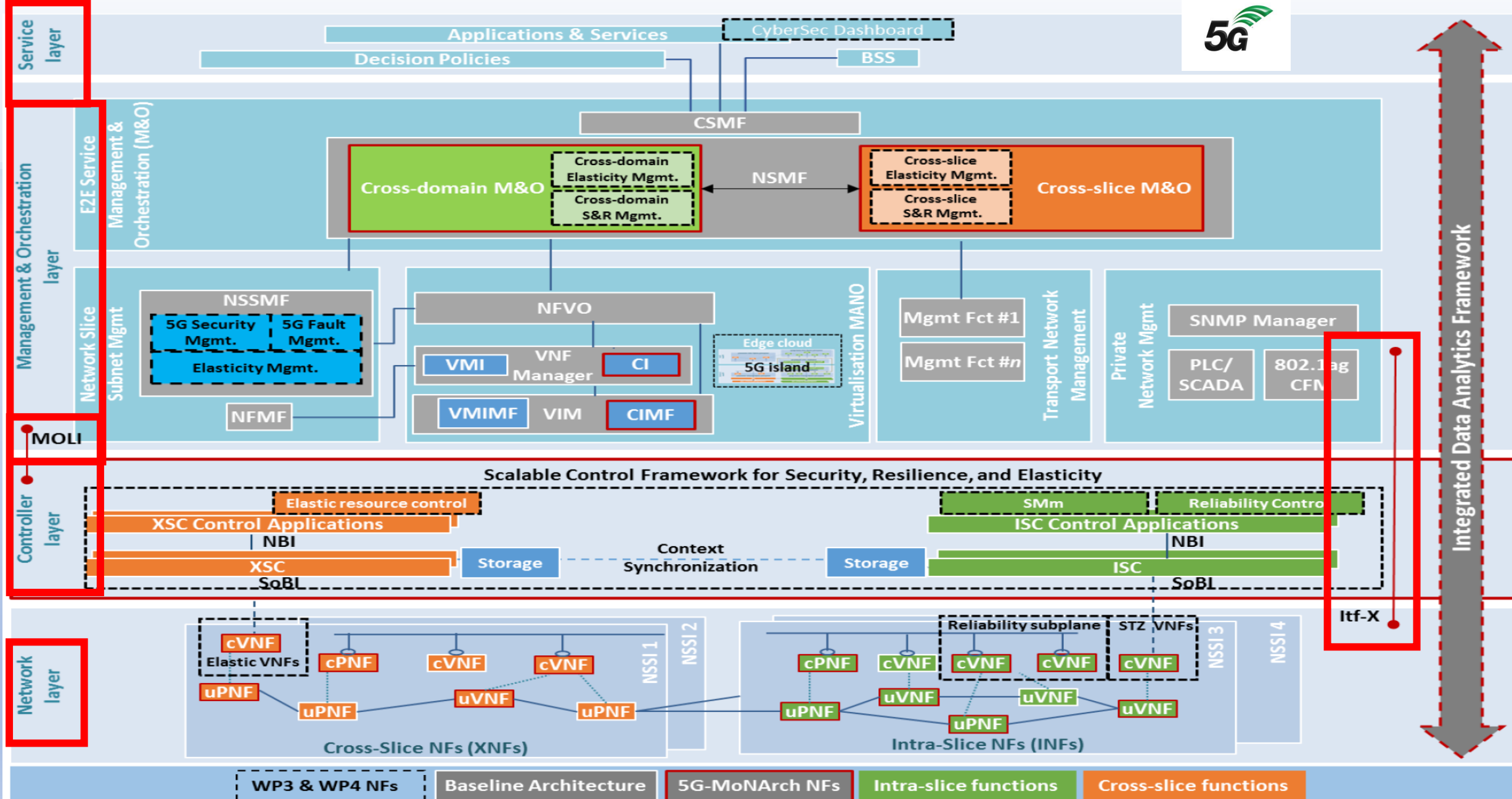

Figure 2-2: 5G Mobile Network overall Architecture

| Communication between consumer and producer | Service discovery and request routing   | Communication model |
|---|---|---------------------|
| Direct communication                        | No NRF or SCP; direct routing   | A                   |
|   | Discovery using NRF services; no SCP; direct routing  | B                   |
| Indirect communication                      | Discovery using NRF services; selection for specific instance from the Set can be delegated to SCP. Routing via SCP                 | C                   |
|   | Discovery and associated selection delegated to an SCP using discovery and selection parameters in service request; routing via SCP | D                   |

**Table E.1-1: Communication models for NF/NF Services interaction**

# 1. 5G NF as a Service "Producer" and "Consumer" (+ Intent)

## 2. 5G NDL - Network Data Layer - separation of the 5G "Compute" from "Storage" via 5G UDM in NFs implementation into VNFs & PNFs related

(NF) Application Context (Unstructured Data in UDSF)  
 from  
 (NF) Application Business Logic (Structured Data in UDR)

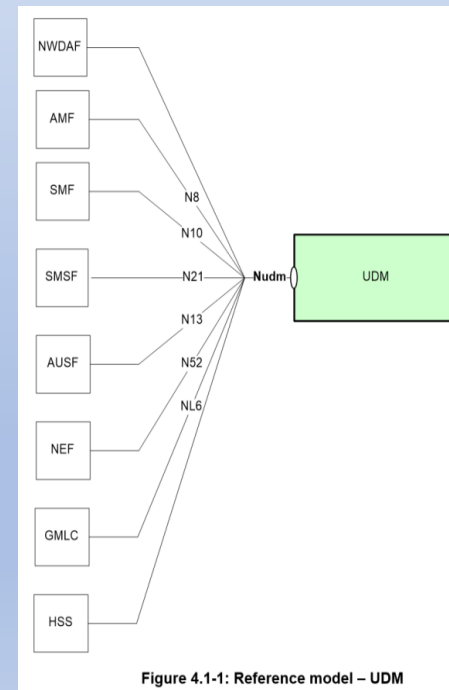

Figure 4.1-1: Reference model - UDM

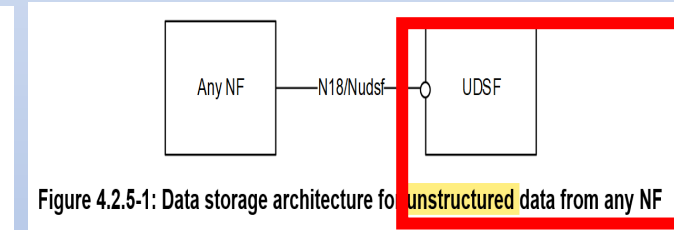

Figure 4.2.5-1: Data storage architecture for unstructured data from any NF

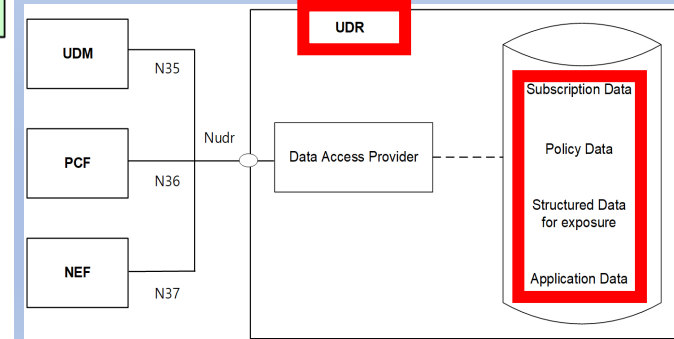

Figure 4.2.5-2: Data storage architecture

# 5G NF/NF Services Interaction as Producer and Consumer

## Model A - Direct communication without NRF interaction:

Neither NRF nor SCP are used. **Consumers** are configured with **Producers' "NF Profiles"** and directly communicate with a **Producer** of their choice.

## Model B - Direct communication with NRF interaction:

**Consumers** do discovery by querying the NRF. Based on the discovery result, the **Consumer** does the selection. The **Consumer** sends the request to the selected **Producer**.

## Model C - Indirect Communication without Delegated Discovery:

**Consumers** do discovery by querying the NRF. Based on discovery result, the **Consumer** does the selection of an **NF Set** or a **specific NF instance of NF instance set**. The **Consumer** sends the request to the **SCP** containing the **address of the selected Service Producer pointing to a NF Service Instance or a set of NF Service Instances**. In the latter case, the **SCP** selects an **NF Service Instance**. If possible, the **SCP** interacts with **NRF** to get selection parameters such as location, capacity, etc. The **SCP** routes the request to the **selected NF Service Producer Instance**.

## Model D - Indirect communication with delegated Discovery:

**Consumers** do not do any discovery or selection. The **Consumer** adds any **necessary Discovery and Selection Parameters** required to find a suitable **Producer** to the **Service** request. The **SCP** uses the request address and the discovery and selection parameters in the request message to route the request to a suitable producer instance. The **SCP** can perform discovery with an **NRF** and obtain a discovery result.

| Communication between consumer and producer | Service discovery and request routing   | Communication model |
|---|---|---------------------|
| Direct communication                        | No NRF or SCP; direct routing   | A                   |
|   | Discovery using NRF services; no SCP; direct routing  | B                   |
| Indirect communication                      | Discovery using NRF services; selection for specific instance from the Set can be delegated to SCP. Routing via SCP                 | C                   |
|   | Discovery and associated selection delegated to an SCP using discovery and selection parameters in service request; routing via SCP | D                   |

Table E.1-1: Communication models for NF/NF Services interaction summary

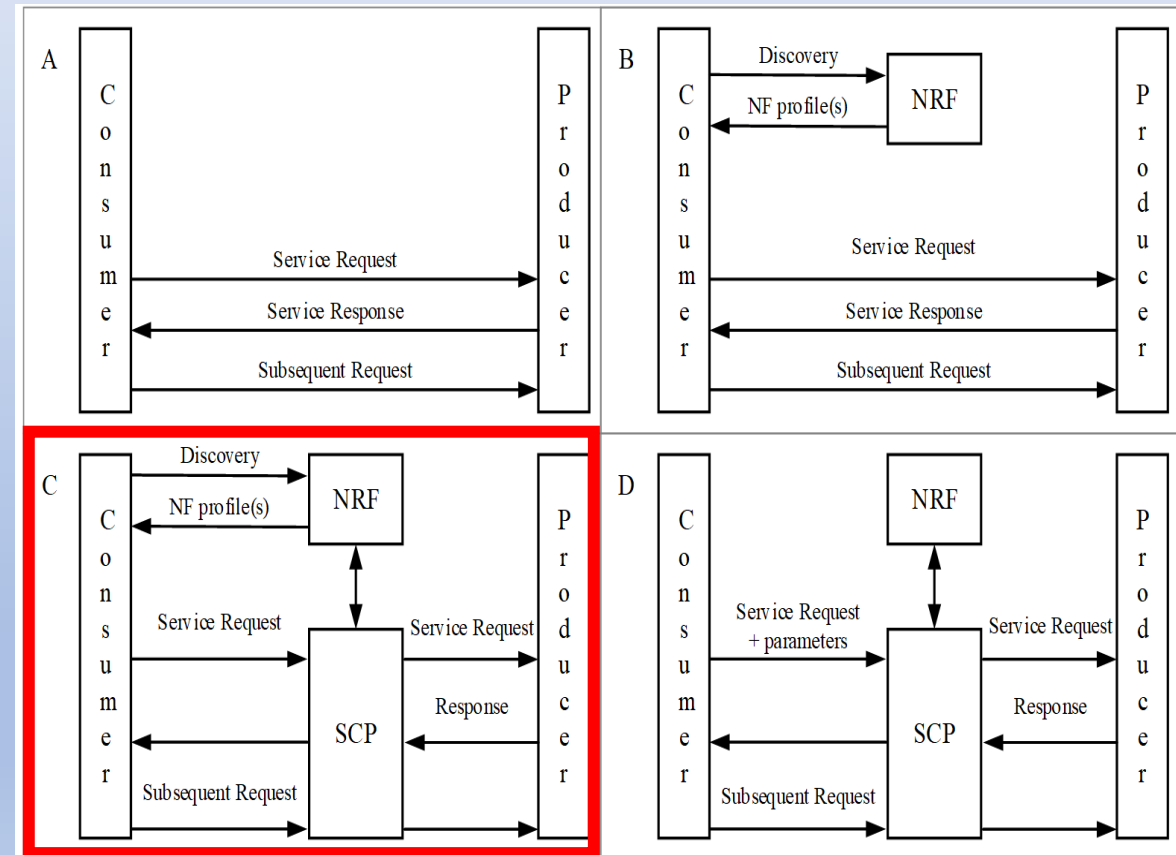

Figure E.1-1: Communication models for NF/NF services interaction

# Management Services (MnS)

An Management Service (MnS) offers Capabilities for Management and Orchestration of Network and Service.

The entity producing an MnS is called **MnS Producer**.

The entity consuming an MnS is called **MnS Consumer**.

**An MnS provided by an MnS Producer can be consumed by any entity with appropriate Authorisation and Authentication.**

An MnS Producer offers its services via a Standardized Service Interface composed of individually specified MnS Components.

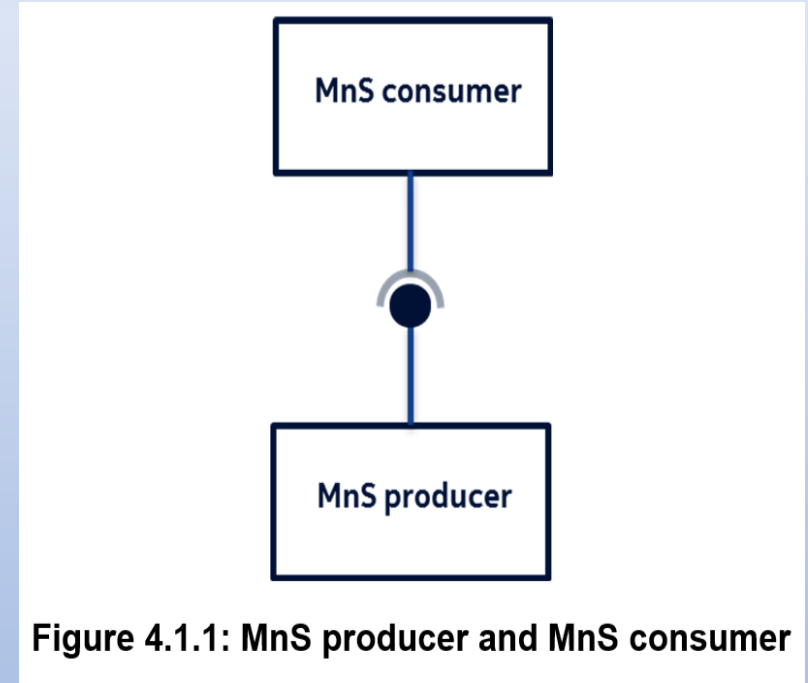

Figure 4.1.1: MnS producer and MnS consumer

# 5G NFs Services as Producer and Consumer

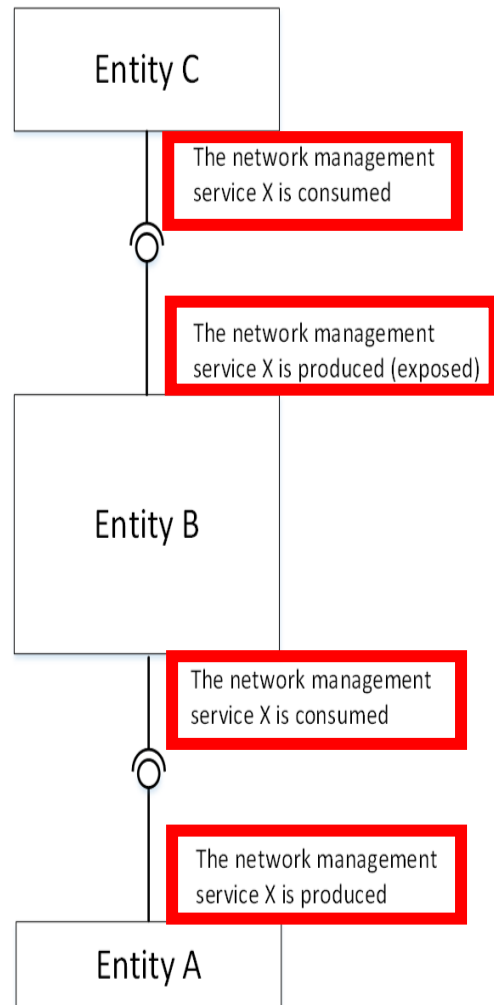

Figure 5.1.1-1. Example of producers and consumers of the management service

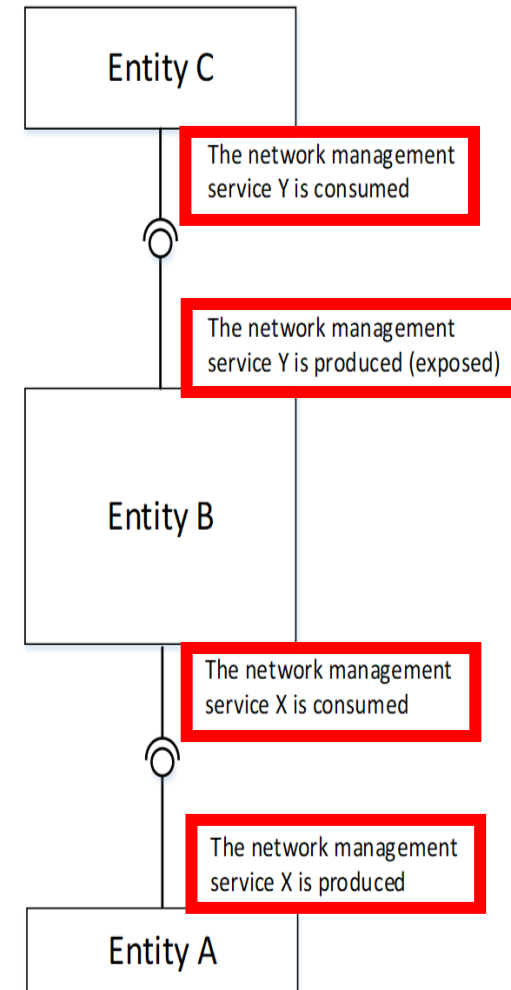

Figure 5.1.1-2. Example of producers and consumers of management services



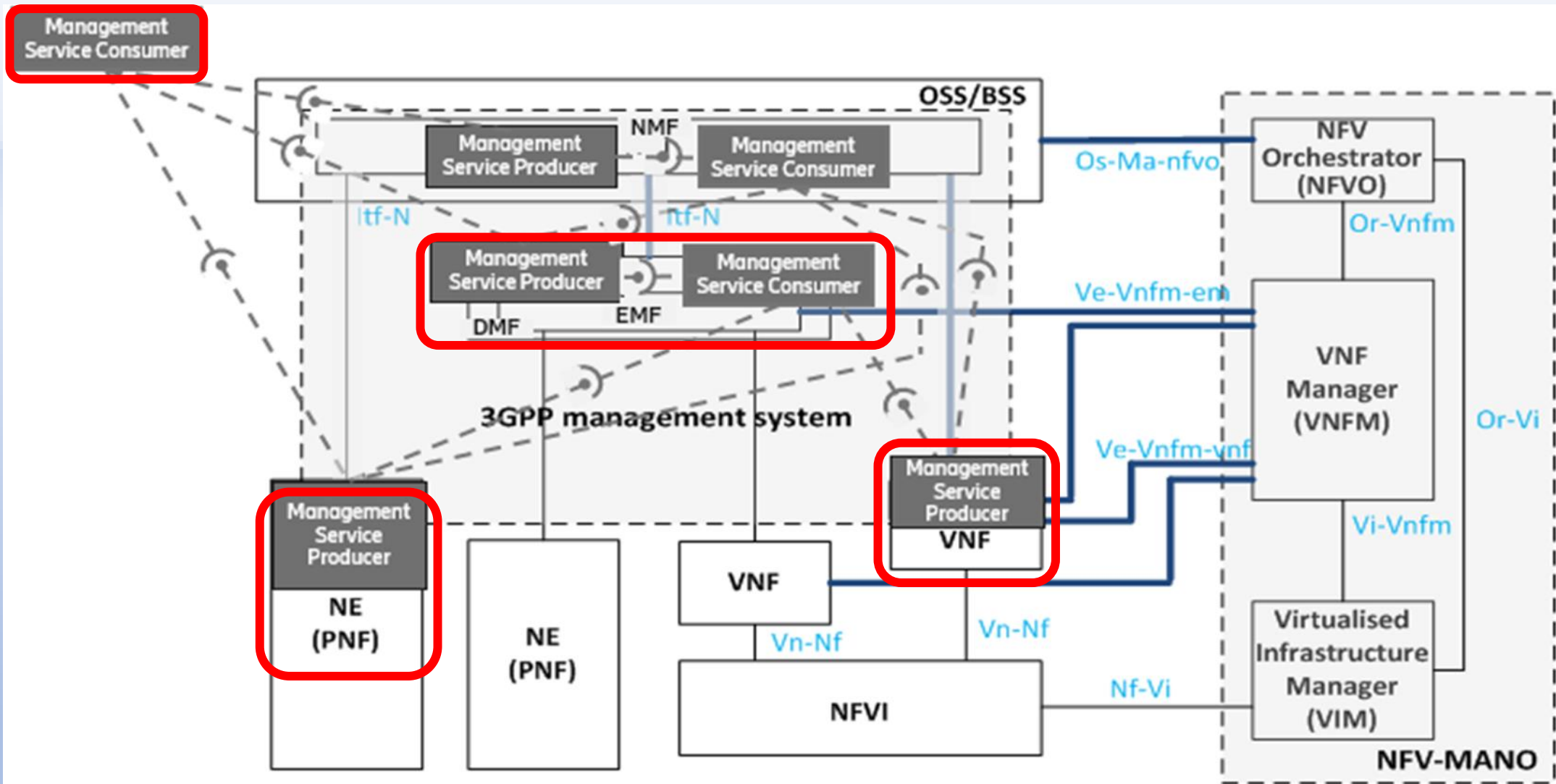
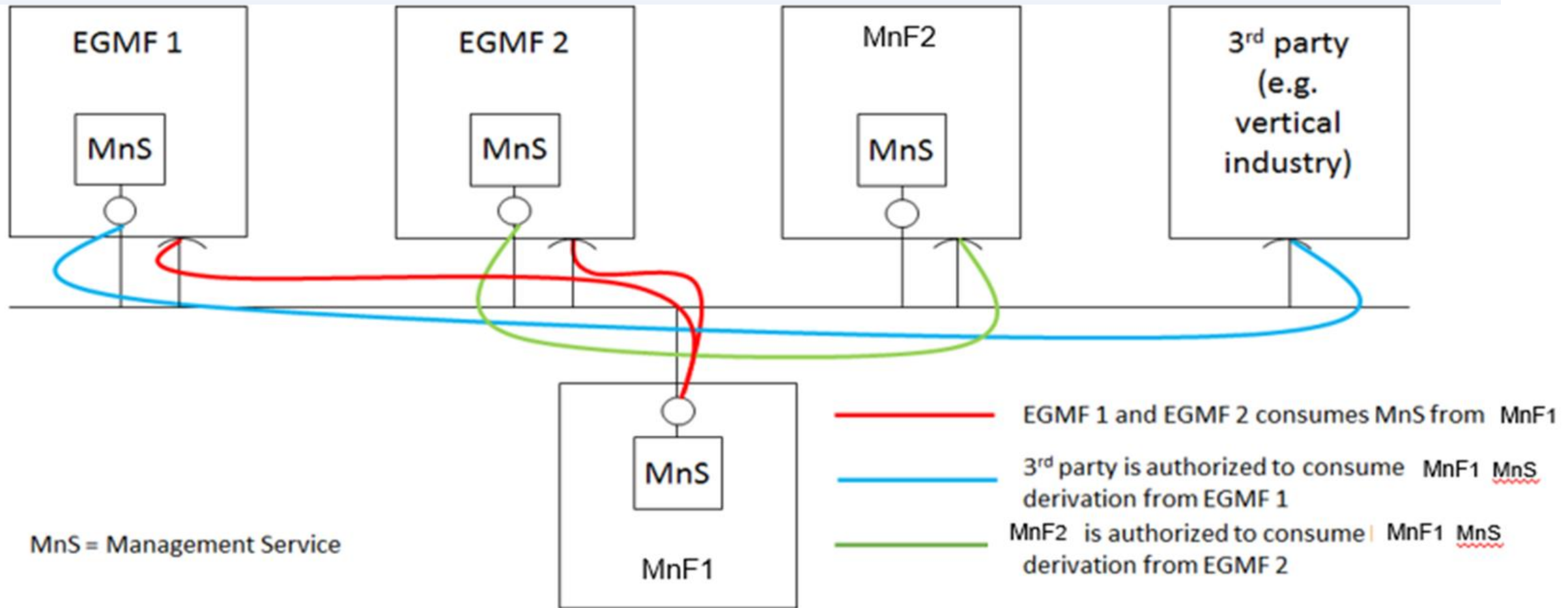

Figure C.1: Example of Management service producer and consumer interaction mapped into the pre-Rel-15 management reference model [10]





**Figure A.3.1: MnF-1 Management Service (MnS) exposed through Exposure Governance Management Function 1 (EGMF 1) and through Exposure Governance Management Function 2 (EGMF 2)**

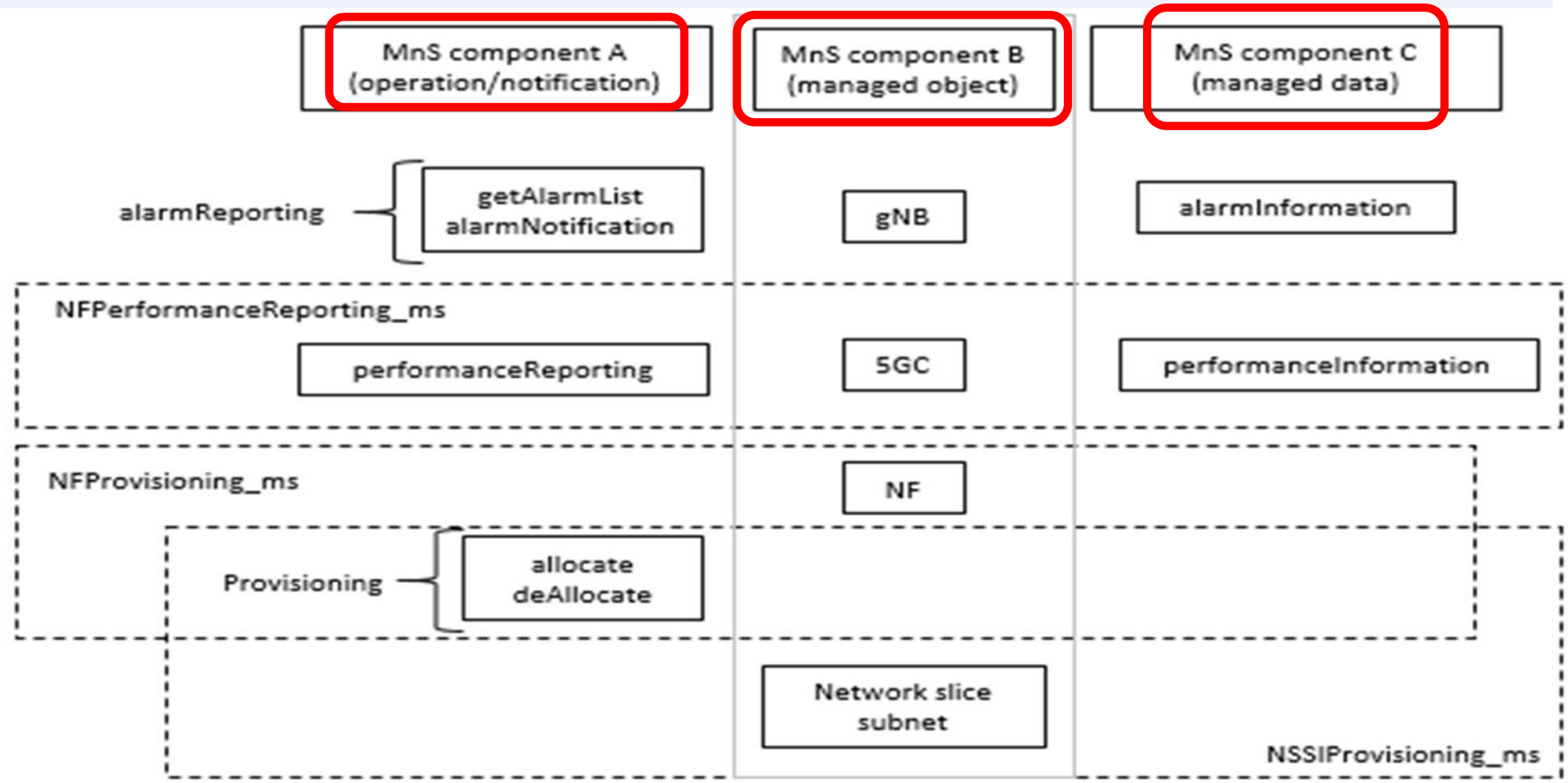

Figure 4.3.1: Example of Management Service and component type A, B and C

# Intent driven Management Service (Intent driven MnS) concept



Perform Network Management Tasks

Identifying, Formulating and Activating Network Management Policies

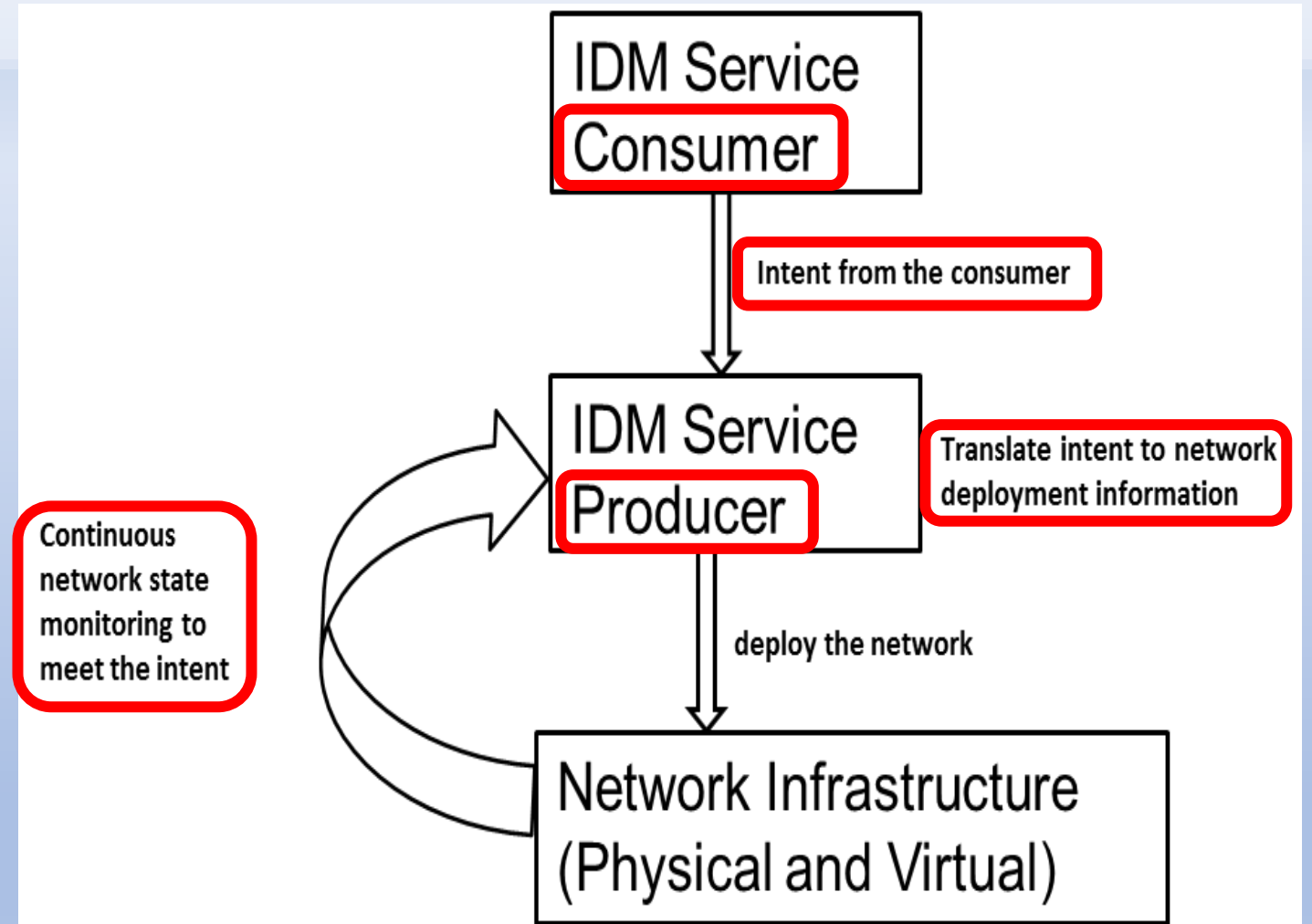

Figure 4.1.2.1-2: An example of using Intent driven management service for network provisioning

- Intent from Communication Service Provider (Intent-CSP)
- Intent from Network Operator (Intent-NOP)

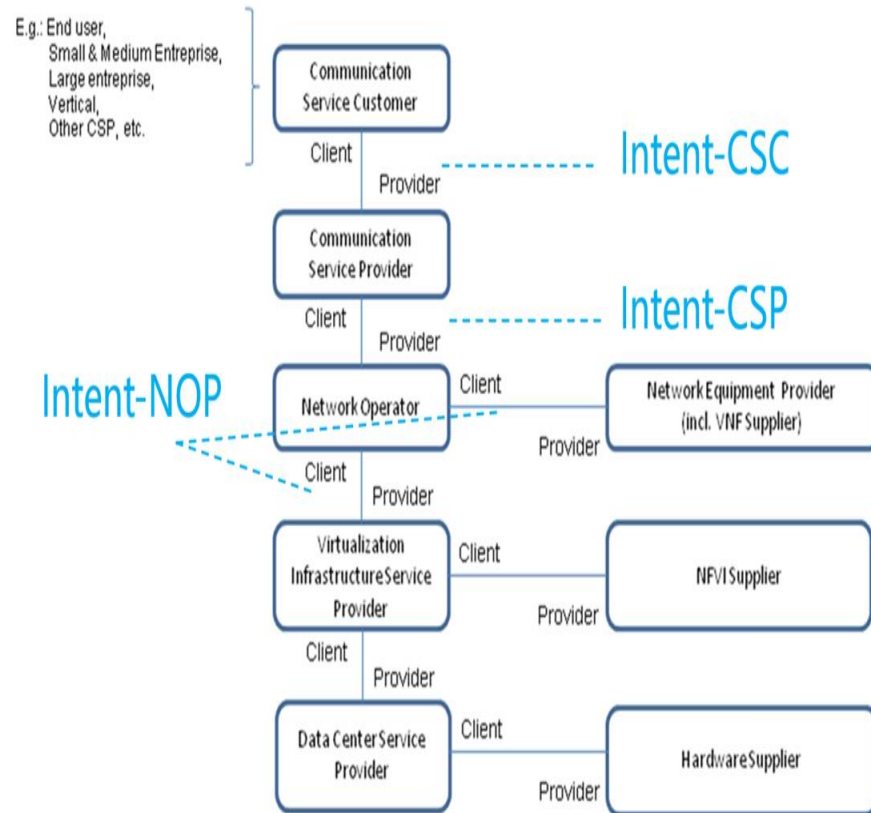

Figure 4.1.2.4-1: Concept for utilization of intent

#### 4.1.2.5 Intent driven Management Service (MnS) interactions with 3GPP management functions

The following figure shows the interaction of intent driven management service (MnS) with management functions.

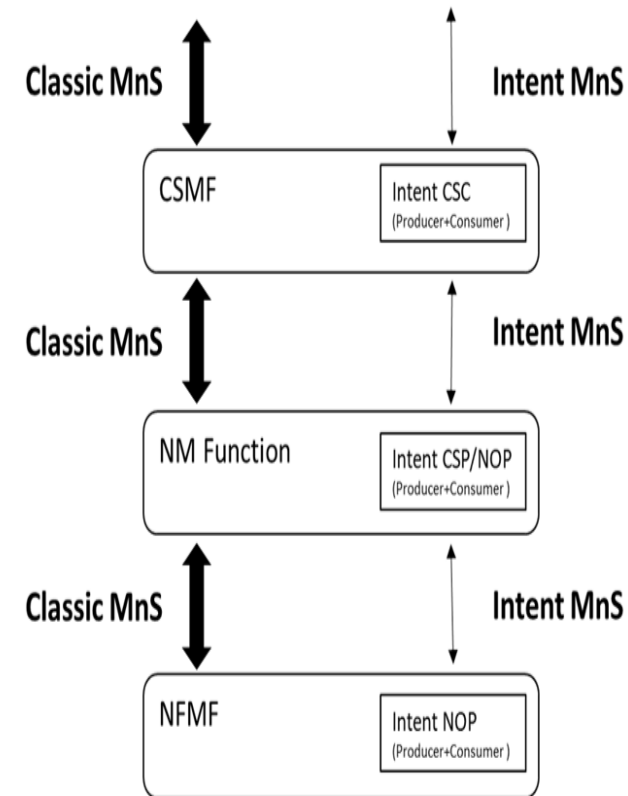
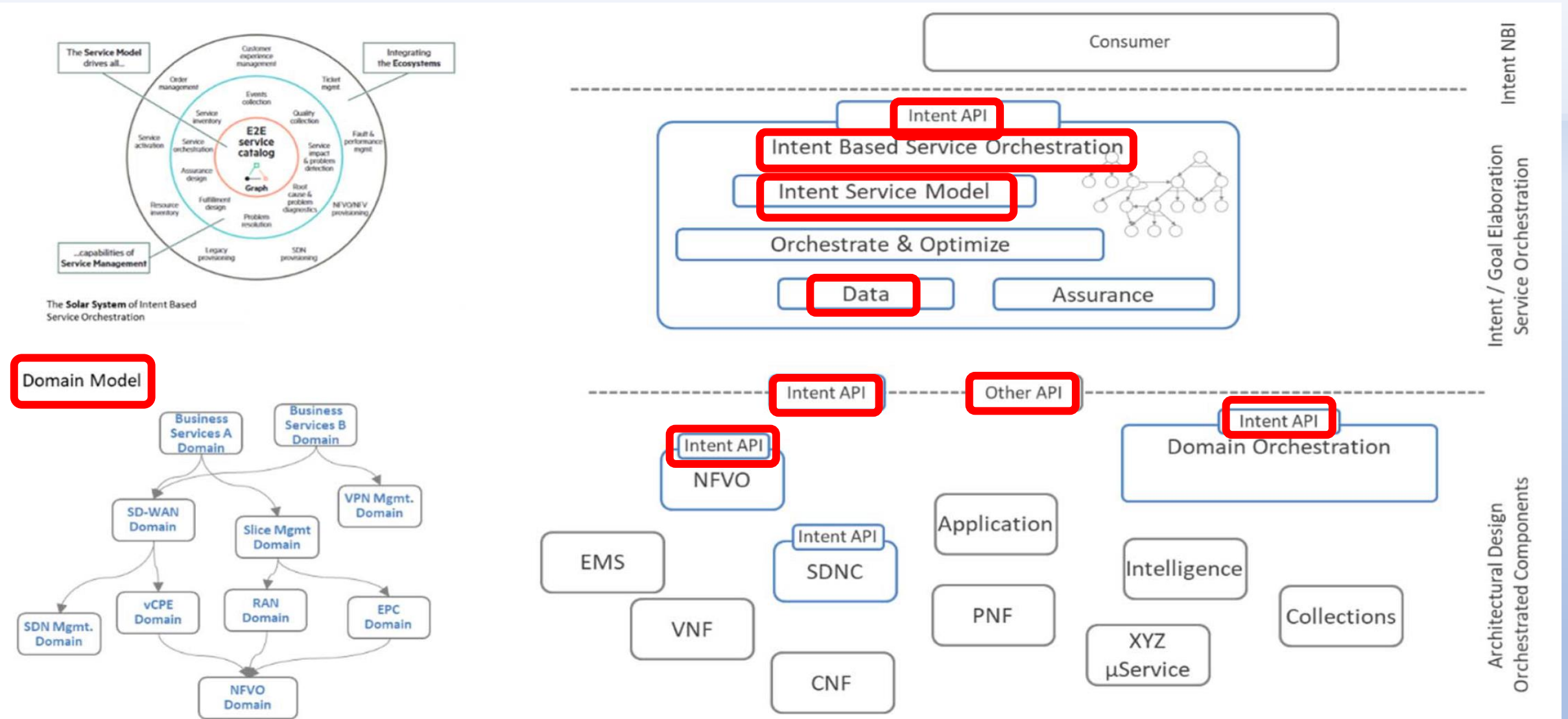

Figure 4.1.2.5.1: The intent driven management service (MnS) vs classic MnS

# 1. "5G Network Mobility at "Cell" & "Cloud" Edge - NGMN WP Feb 2015 - 8



**Figure 10: Intent-based Service Orchestration across Domains, driven by Intent-based Service Models**

Interface 1: NWDAF interacts with AF (via NEF) using NW layer SBI.

Interface 2: N1/N2 interface.

Interface 3: O&M layer configures the NF profile in the NRF, and NWDAF collect the NF capacity information from the NRF.

**Interface 4: MDAF interacts with Application/Tenant using Northbound Interfaces (NBI).**

Interface 5: MDAF interacts with RAN DAF using O&M layer SBI.

Interface 6: NWDAF consumes the services provided by MDAF using cross layer SBI.

Interface 7: MDAF consumes the services provided by MWDAF using cross layer SBI.

Interface 8: MDAF collects data from NW layer via trace file/monitoring services.

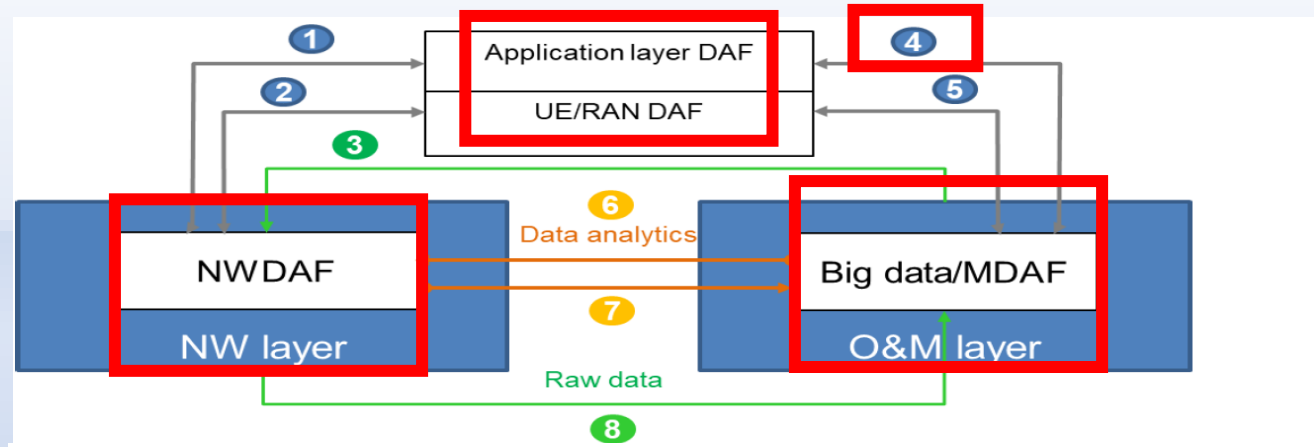

Figure 4-3: Data Analytics framework in 5G Mobile Network Architecture

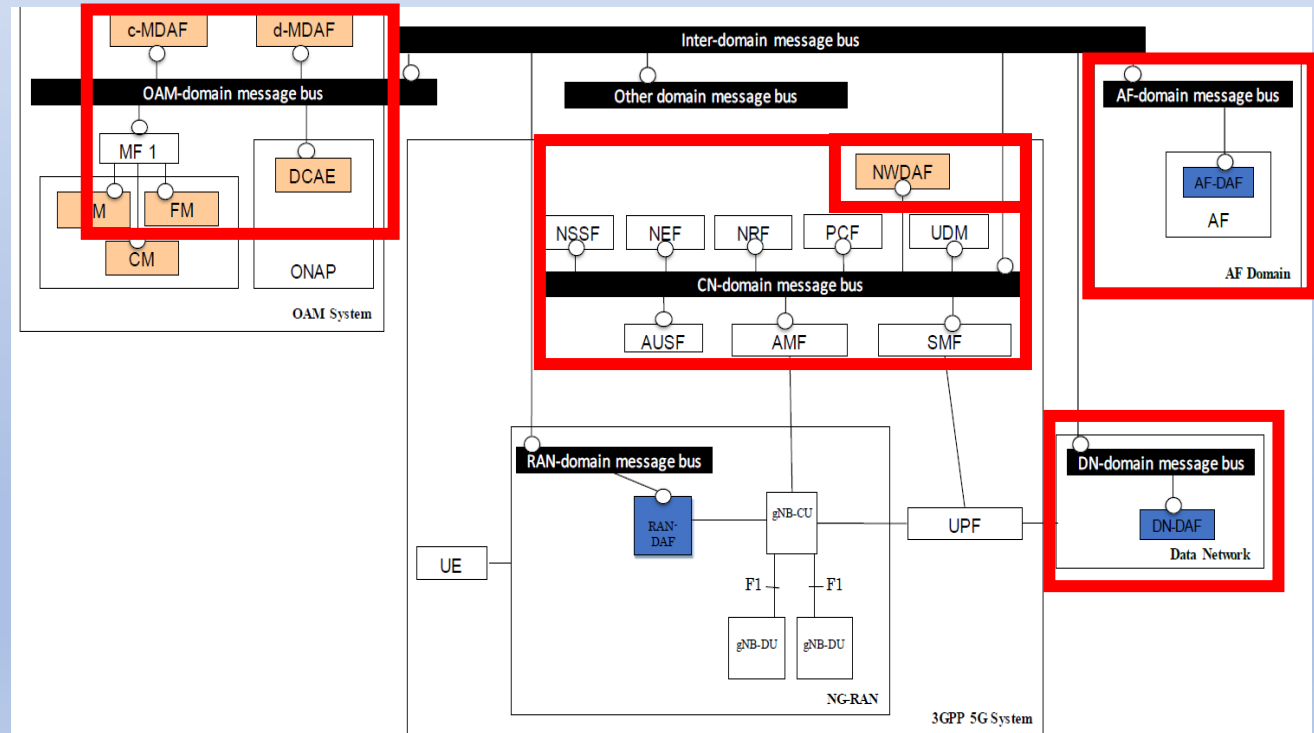

Figure 4-4 5G Mobile Network Architecture Integrated Analytics Architecture



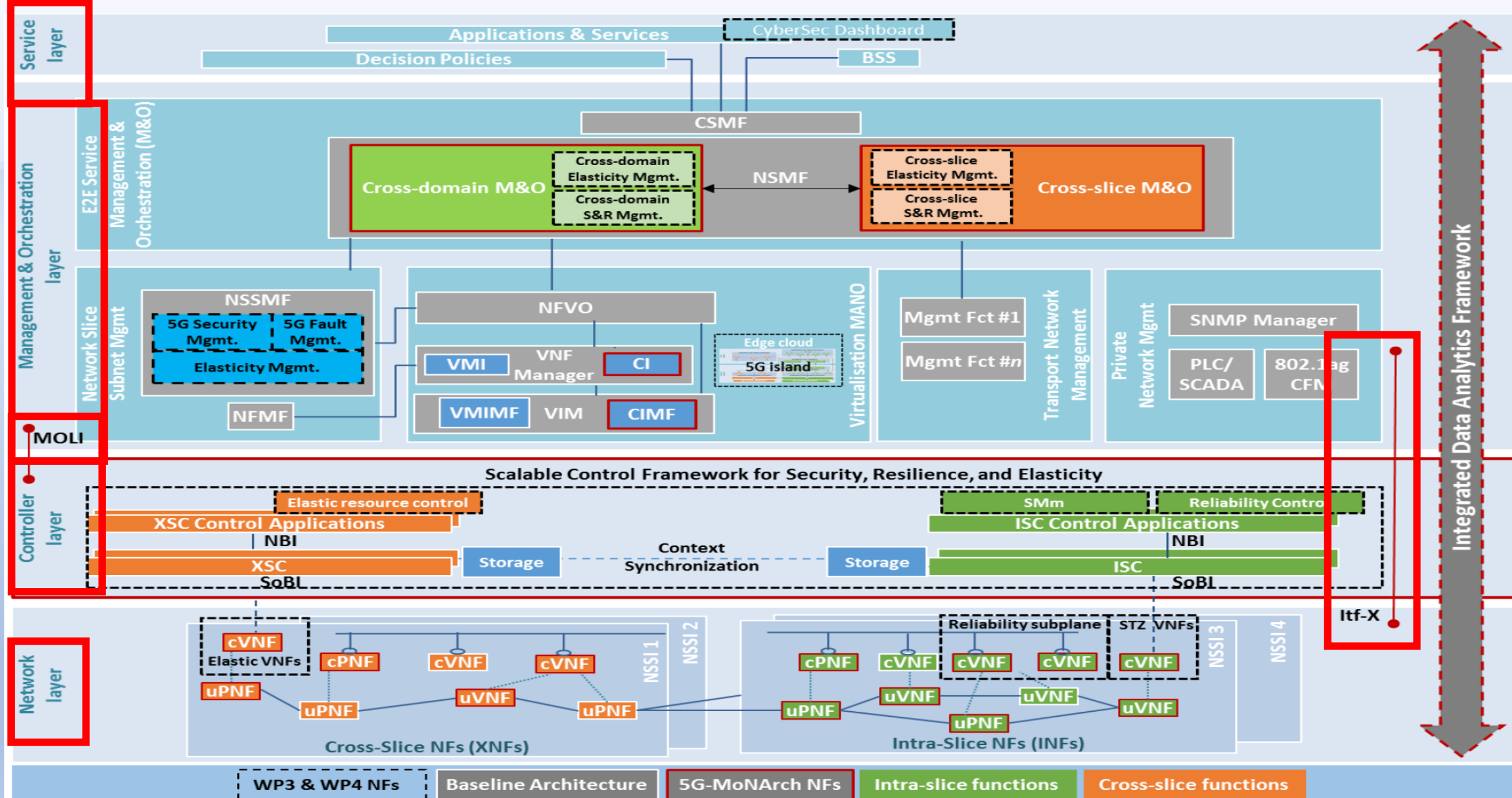
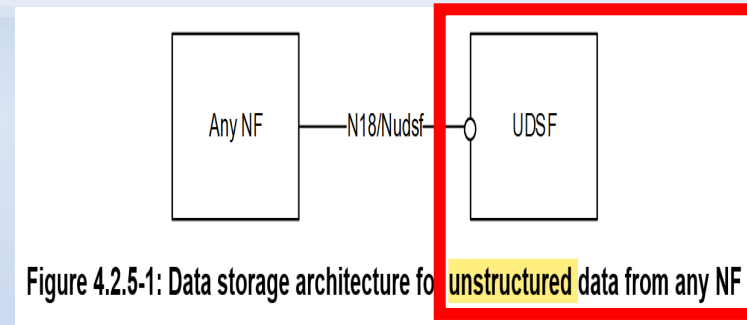

Figure 2-2: 5G Mobile Network overall Architecture

## 2. 5G NDL - Network Data Layer - separation of the 5G "Compute" from "Storage" via 5G UDM in NFs implementation into VNFs & PNFs related

**(NF) Application Context (Unstructured Data in UDSF)**



from

**(NF) Application Business Logic (Structured Data in UDR)**

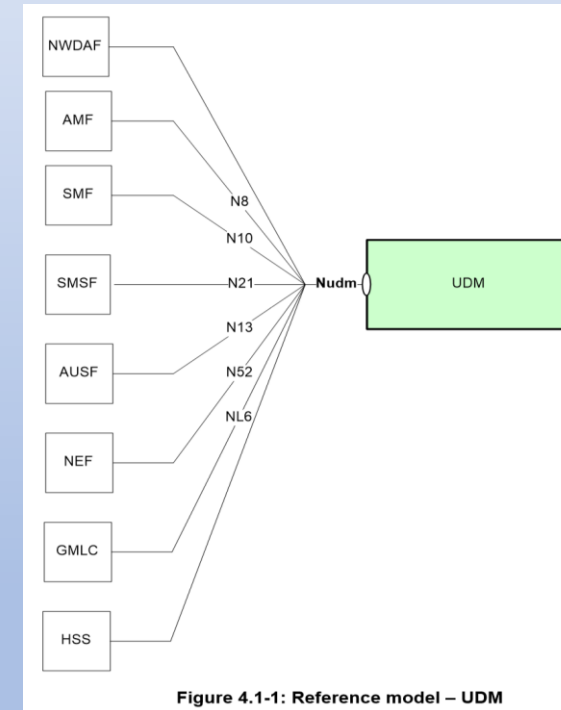
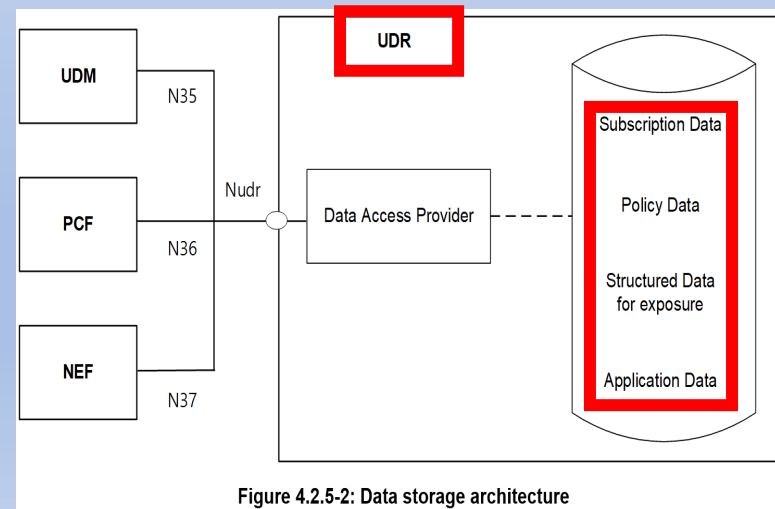



# Stateless NFs (for any 5GC NF type)

An NF may become Stateless by **Storing its Contexts as Unstructured Data in the UDSF**.

An UDM, PCF and NEF may also Store own **Structured Data in the UDR**.

An UDR and UDSF cannot become stateless.

An NF may also be deployed such that several stateless network function instances are present within a set of NF instances. Additionally, within an NF, an NF service may have multiple instances grouped into a NF Service Set if they are interchangeable with each other because they share the same context data. See clause 5.21 of 3GPP TS 23.501 [3].

## 6.5.3 Stateless NFs (for any 5GC NF type)

### 6.5.3.1 General

An NF may become stateless by storing its contexts as unstructured data in the UDSF. An UDM, PCF and NEF may also store own structured data in the UDR. An UDR and UDSF cannot become stateless.

An NF may also be deployed such that several stateless network function instances are present within a set of NF instances. Additionally, within an NF, an NF service may have multiple instances grouped into a NF Service Set if they are interchangeable with each other because they share the same context data. See clause 5.21 of 3GPP TS 23.501 [3].

A UDM / AUSF / UDR / PCF group may consist of one or multiple UDM / AUSF / UDR / PCF sets.

### 6.5.3.2 Stateless NF as service consumer

1. When the NF service consumer subscribes (explicitly or implicitly) to notifications from another NF service producer, the NF service consumer may provide a binding indication to the NF service producer as specified in clause 6.3.1.0 of 3GPP TS 23.501 [3] and clause 4.17.12.4 of 3GPP TS 23.502 [4], to enable the related notifications to be sent to an alternative NF service consumer within the NF (service) set, in addition to providing the Callback URI in the subscription resource.
2. A NF service producer or SCP may use the Nnrf\_NFDiscovery service to discover NF service consumers within an NF (service) set.
3. An NF service producer may become aware of a NF service consumer change, via receiving an updated binding information (i.e. when the binding entity corresponding to the binding level is changed), or via an Error response to a notification, via link level failures (e.g. no response from the NF), or via a notification from the NRF that the NF service consumer has deregistered. The HTTP error response may be a 3xx redirect response pointing to a new NF service consumer.

NOTE: When the binding entity other than the one corresponding to the binding level is changed, it indicates the

# Stateless NFs (for any 5GC NF type) - AMF stores the Context for registered UE(s) in the UDSF

Table 5.2.14-1: NF Services provided by UDSF

| NF service                   | Service Operations | Operation Semantics | Example Consumer(s) |
|------------------------------|--------------------|---------------------|---------------------|
| Unstructured Data Management | Query              | Request/Response    | Any NF              |
|                              | Create             | Request/Response    | Any NF              |
|                              | Delete             | Request/Response    | Any NF              |
|                              | Update             | Request/Response    | Any NF              |

NOTE: Nudsf is different compared to other service-based interfaces due to dynamic data access performance requirements.

## 5.2.14.2 Nudsf\_UnstructuredDataManagement service

### 5.2.14.2.1 General

### 5.2.14.2.2 Nudsf\_UnstructuredDataManagement\_Query service operation

**Service operation name:** Nudsf\_UnstructuredDataManagement\_Query.

**Description:** NF service consumer intends to query data from UDSF.

**Inputs, Required:** Data Identifier.

Data Identifier uniquely identifies the data to be retrieved from the UDSF

**Inputs, Optional:** None.

**Outputs, Required:** Requested data.

**Outputs, Optional:** None.

### 5.2.14.2.3 Nudsf\_UnstructuredDataManagement\_Create service operation

**Service operation name:** Nudsf\_UnstructuredDataManagement\_Create.

**Description:** NF service consumer intends to insert a new user data record into the UDSF, e.g. AMF stores the context for registered UE(s) in the UDSF.

# Context Definition

One of the most popular definitions of context is: "**Context** is any information that can be used to **characterize the situation of an entity**."

**An "Entity" is a Person, Place, or Object** that is considered relevant to the interaction between a user and an application, including the user and application themselves" .

The updated definition of Context is:

***"The Context of an Entity is a Collection of Measured and Inferred Knowledge that describe the State and Environment in which an Entity exists or has existed".***

This definition emphasizes two (2) Types of Knowledge

1. **Facts** (which can be measured) and
2. **Inferred Data**, which results from **ML & Reasoning Processes** applied to **Past & Current Context**.

It also includes Context History, so that current decisions based on Context may benefit from past decisions, as well as Observation of How the Environment has changed.

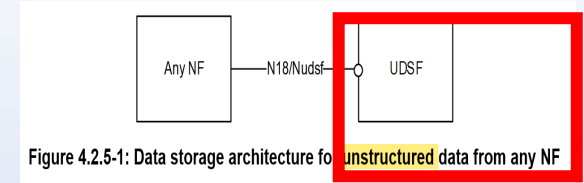

# 5G Guidelines & Principles for Compute - Storage Separation

## Data Storage Architectures

As depicted in Figure 4.2.5-1, the 5G System Architecture allows any NF to store and retrieve its Unstructured Data into/from a UDSF (e.g. UE Contexts).

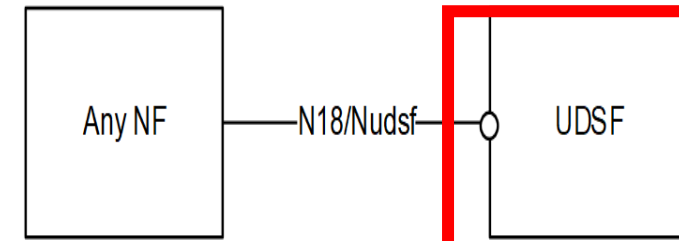

Figure 4.2.5-1: Data storage architecture for unstructured data from any NF

As depicted in Figure 4.2.5-2, the 5G System Architecture allows the UDM, PCF and NEF to store data in the UDR (Fig. 4.2.5-2), including:

**Subscription Data and Policy Data** by UDM and PCF,

**Structured Data for Exposure and**

**Application Data** (including Packet Flow Descriptions (PFDs) for Application Detection, AF request information for multiple UEs) by the NEF.

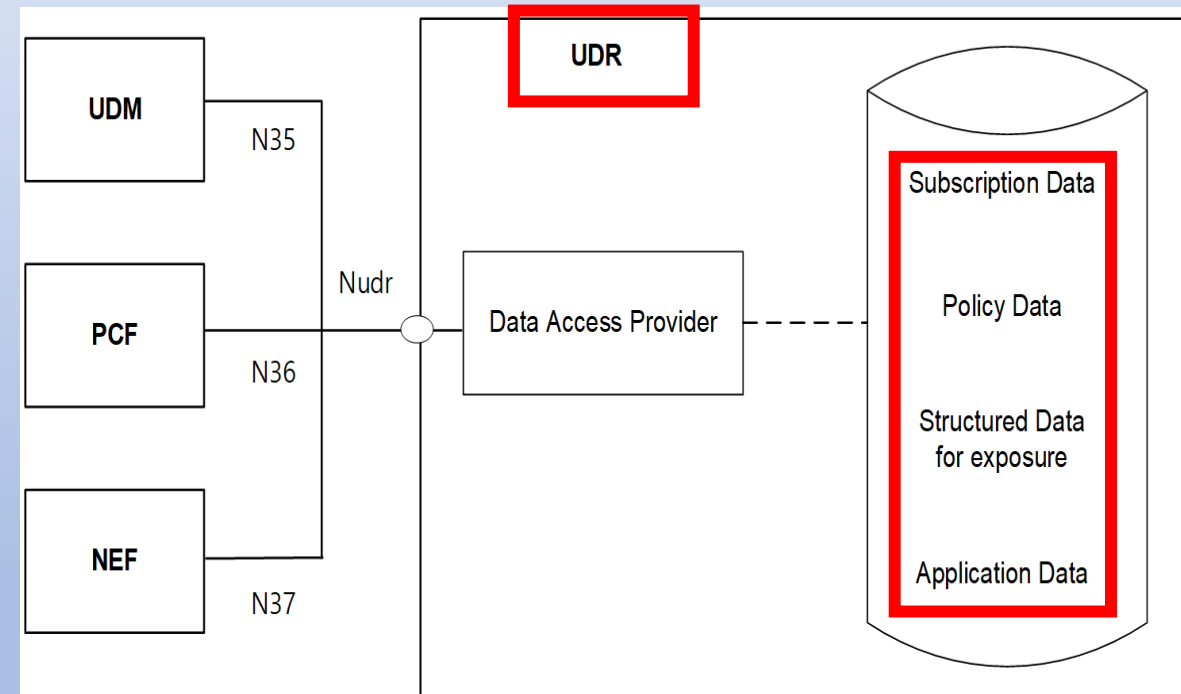

Figure 4.2.5-2: Data storage architecture

# 5G System Architecture Rel 16 Access Traffic Steering, Switch and Splitting (ATSSS)

The ATSSS feature enables a **Multi-Access (MA) PDU Connectivity Service**, which can exchange PDUs between the UE and a Data Network (DN) by simultaneously using one (1) 3GPP Access Network and one (1) non-3GPP Access Network and two (2) independent N3/N9 tunnels between the PSA and RAN/AN.

The Multi-Access PDU Connectivity Service is realized by establishing a Multi-Access PDU (MA PDU) Session, i. e. a **PDU Session that may have User-Plane (UP) Rsource on two(2) Access Networks (ANs)**.

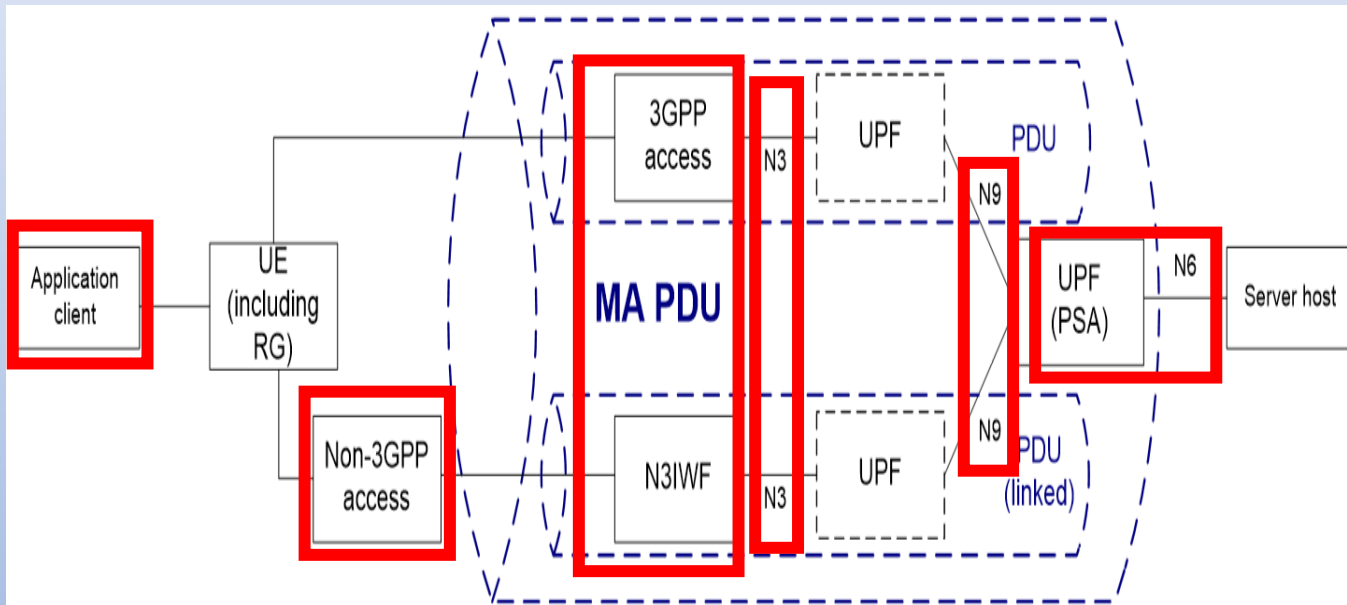

Figure 1: MA PDU session

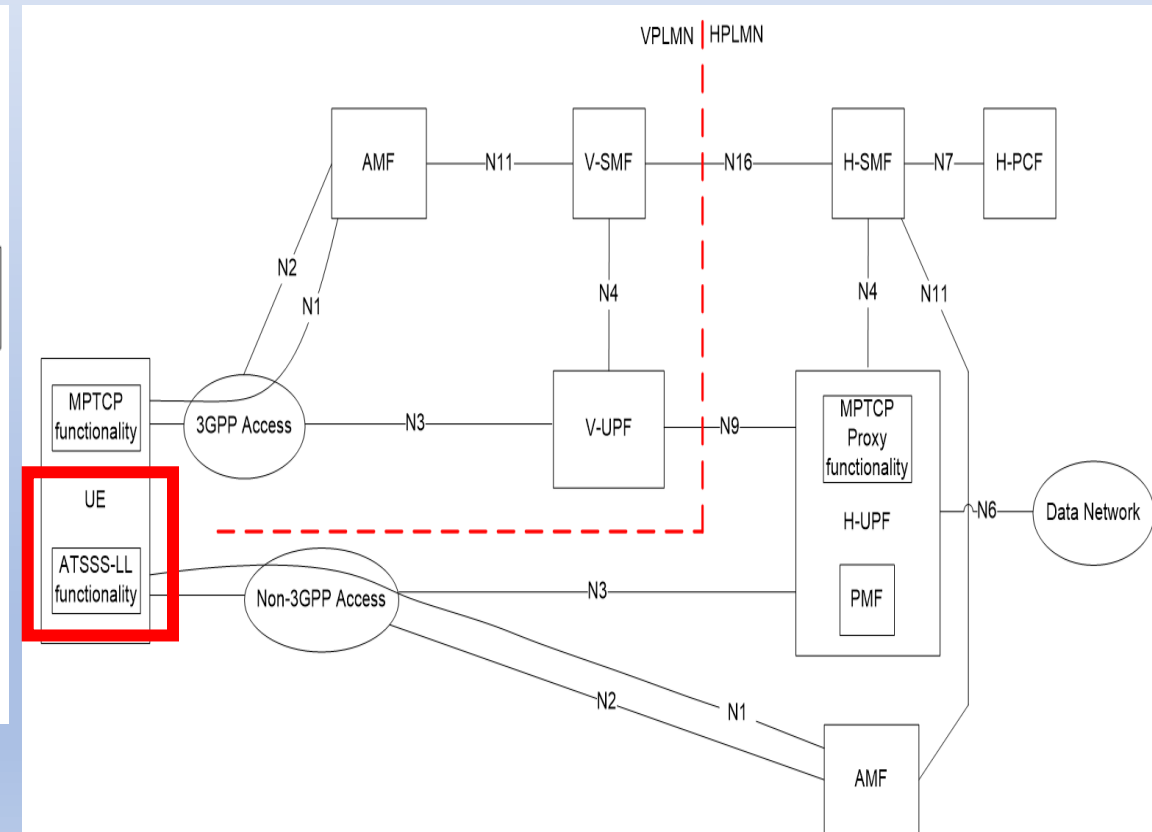

Figure 4.2.10-3: Roaming with Home-routed architecture for ATSSS support (UE registered to different PLMNs)



# 3GPP 5G Network and Wi-Fi Network Communication Availability and Reliability

Relation of Communication Service:

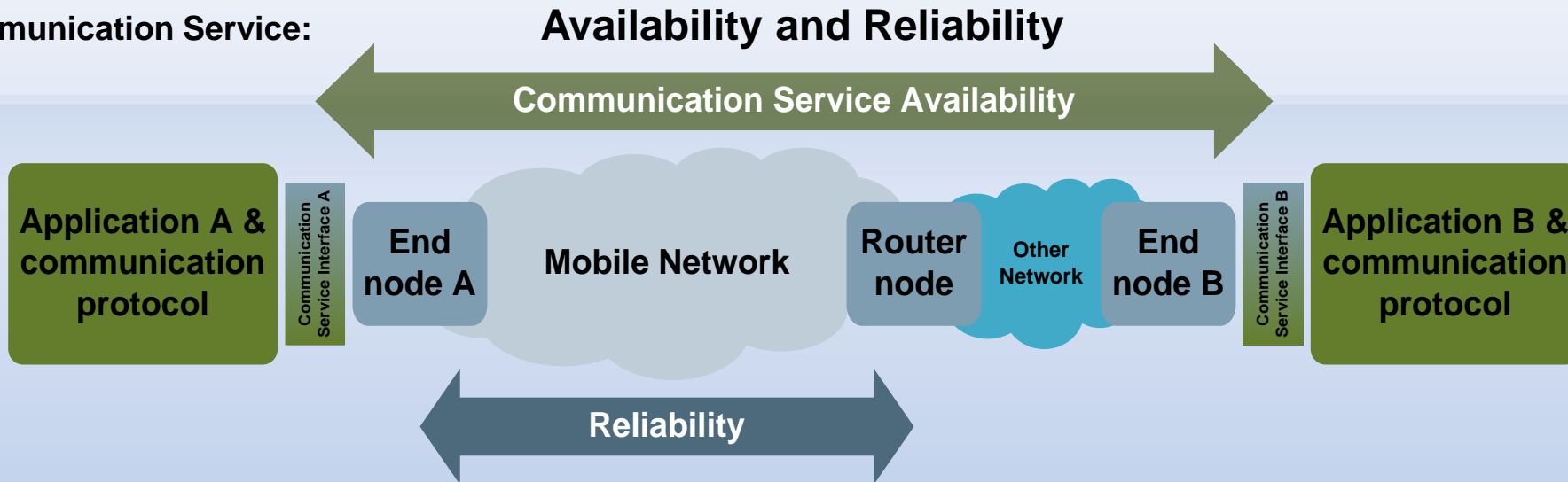

Figure C-4: Example in which communication Service Availability & Reliability have different values.

Packets are delivered over a daisy chain of a Mobile Network and another Network (e.g. IEEE 802.11n based).

Reliability is evaluated for the Mobile Network only,  
Availability depends on the performance of both Networks.

Communication Service **Availability** - measured between the two (2) Communication Service Interfaces,  
**Reliability** - measured between End Node A and the Router Node.

This has implications for, e.g. the maximum communication latency allowed for each network. In case the agreed end-to-end latency between the service interfaces is, for instance, 100 ms. and the 802.11n network has a latency of 30 ms. the maximum allowable latency for packages in the mobile network is 70 ms. (NOTE). So, if the latency in the mobile network exceeds 70 ms, the communication service availability is 0%, despite the agreed QoS stipulating a larger end-to-end latency, i.e. 100ms.

NOTE: The transit time through the router node is not considered here. It is assumed to be very small and much less than 100 ms.

# Service Subscriptions related to Latency in Standardized and Private Slice Types

Network Slice Providers can build their Network Slice Product offering based on S-NESTs (Standardized Network Slice Type) and/or their P-NESTs (**Private NESTs**).

**Standardized Network Slice Type (S-NEST) NST-A**, for which the attribute Packet Delay Budget Value Range is between **1 ms and 100 ms** is specified by 3GPP.

Network Slice Provider (**NSP**) may offer 3 products based on **NST-A**:

- **Platinum NST-A** based Network Slice Product, where the attribute 'Packet Delay Budget' Value Range is between **1 ms and 10 ms**
- **Gold NST-A** based Network Slice Product, where the attribute 'Packet Delay Budget' Value Range is between **11 ms and 50 ms**
- **Silver NST-A** based Network Slice Product, where the attribute 'Packet Delay Budget' Value Range is between **51 ms and 100 ms**.

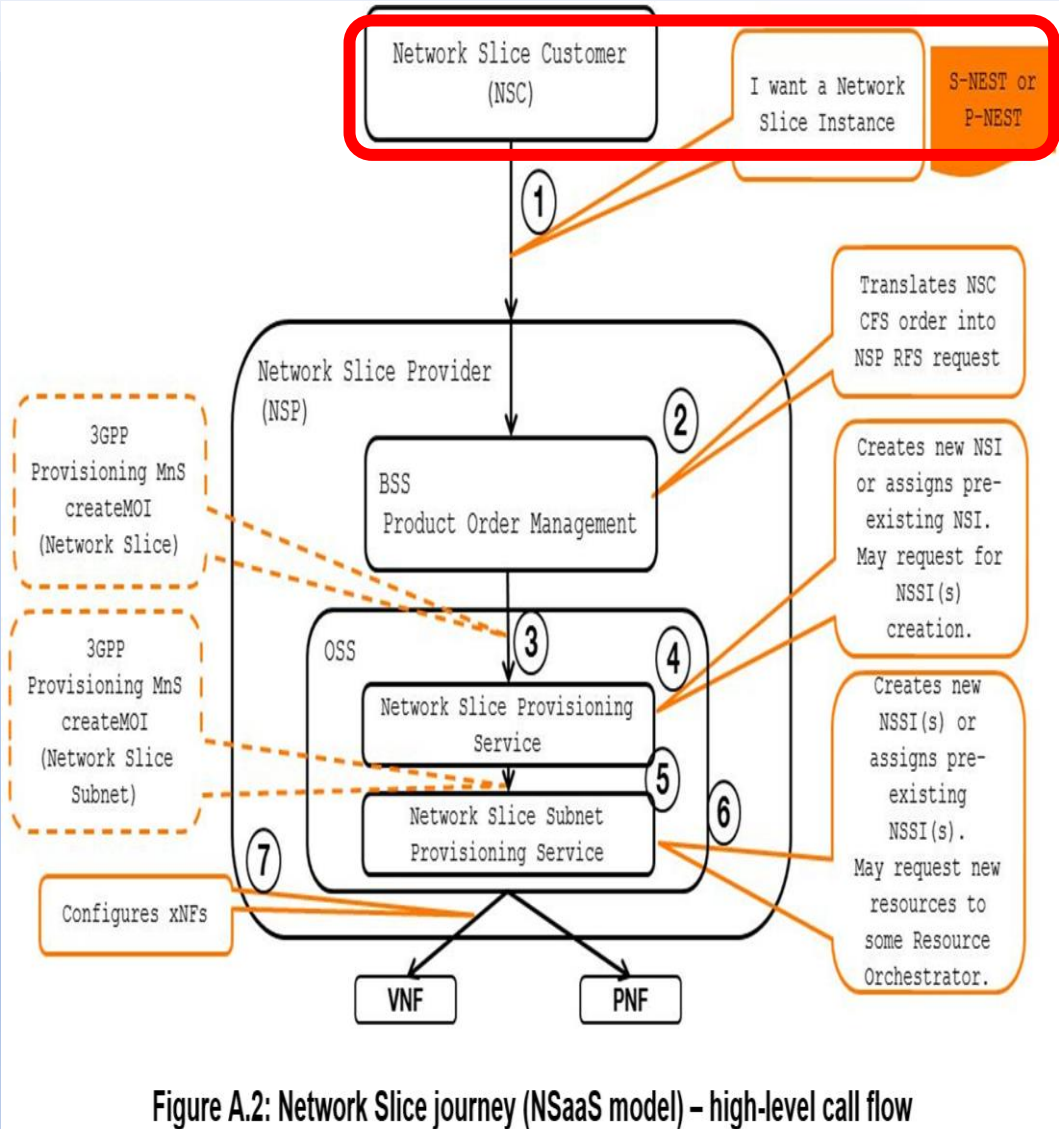

Figure A.2: Network Slice journey (NSaaS model) – high-level call flow

# 3GPP 5G NAPS -Northbound Application Program Interfaces (APIs) - 1

## 5G NAPS Reference model

The NEF Northbound Interface resides between the NEF and the AF.

It specifies RESTful APIs that allow the AF to access the Services and Capabilities provided by 3GPP Network Entities and securely exposed by the NEF.

An AF can get services from multiple NEFs, and an NEF can provide services to multiple AFs.

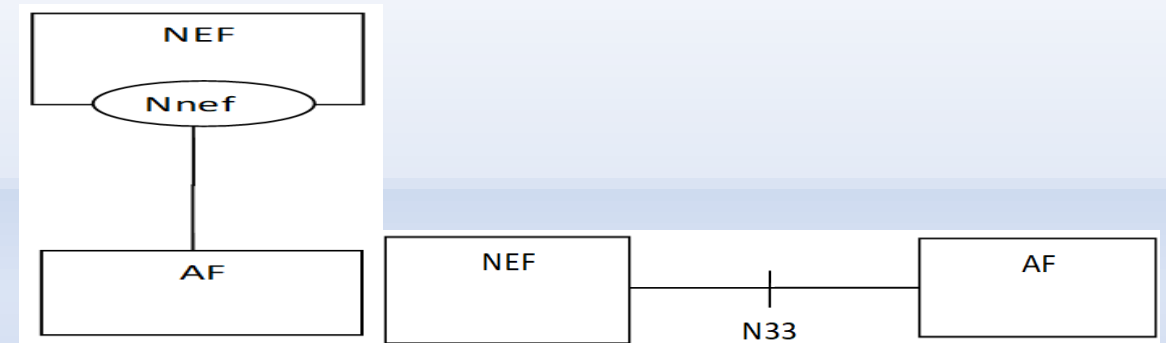

Fig. Reference Architecture for the Nnef Service SBI & Reference Point representation

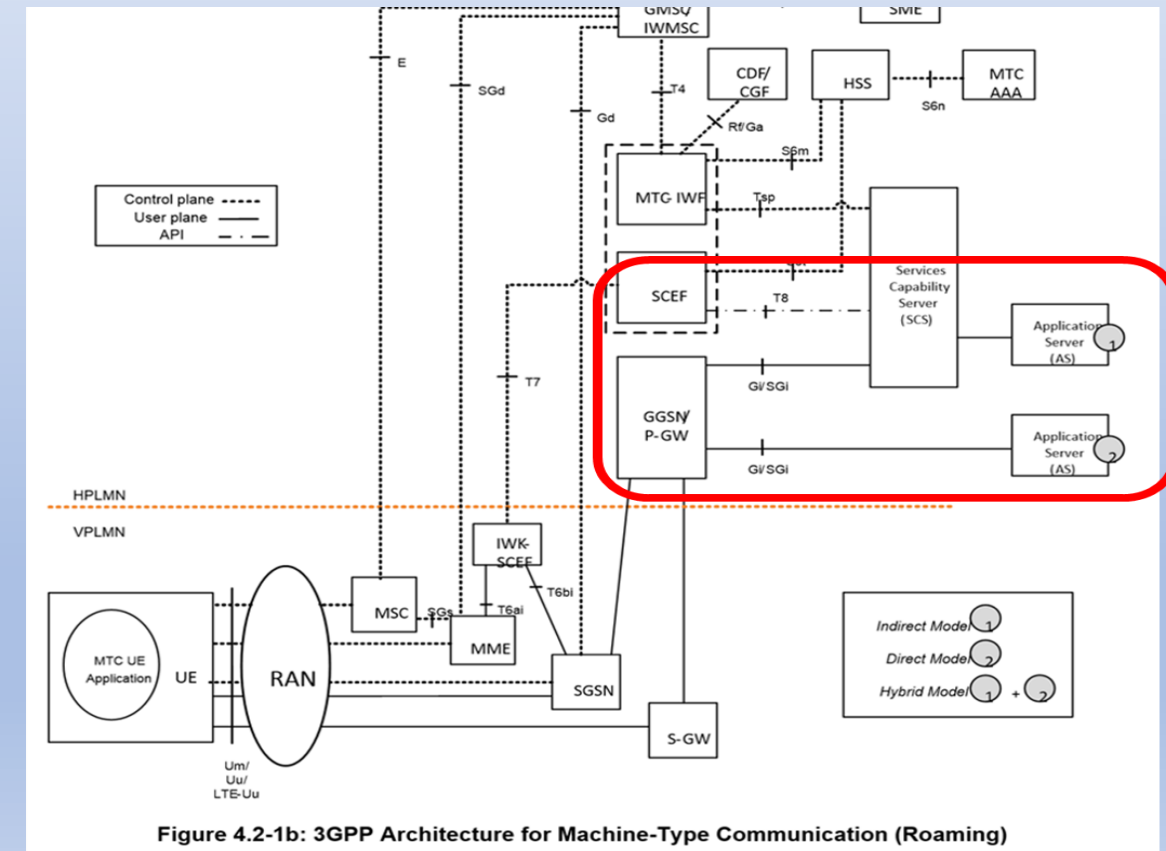

Figure 4.2-1b: 3GPP Architecture for Machine-Type Communication (Roaming)

# 3GPP 5G Rel. 18 SNA - SEES and FMSS NAPS to 5G Subscriber -2

"The Operator shall be able to provide to a 3rd Party Service Provider secure and chargeable access to the Exposed Services/Capabilities i.e. to Authenticate, Authorize and Charge the 3rd Party entities."

MNO can allow the API access of an 3rd Party entity by taking into account the 5GS Subscriber-based check.

Possibility of utilizing those APIs can be open directly to the 5GS subscriber. MNOs need to be cautious of securing its 5GS Subscribers' Privacy.

|               |   |
|---------------|---|
| Source:       | SA1 (from S1-203296)                                    |
| Title:        | New WID on Subscriber-aware Northbound API access (SNA) |
| Document for: | Approval  |
| Agenda Item:  | 6.6   |

## 3GPP™ Work Item Description

Information on Work Items can be found at <http://www.3gpp.org/Work-Items>  
See also the [3GPP Working Procedures](#), article 39 and the TSG Working Methods in [3GPP TR 21.900](#)

Title: Subscriber-aware Northbound API access

Acronym: SNA

Unique identifier: 890024

Potential target Release: Rel-18

Note that this field above indicates the proposed Release at the time of submission of the WID to TSG approval. It can later be changed without a need to revise the WID. The updated target Release is indicated in the Work Plan.

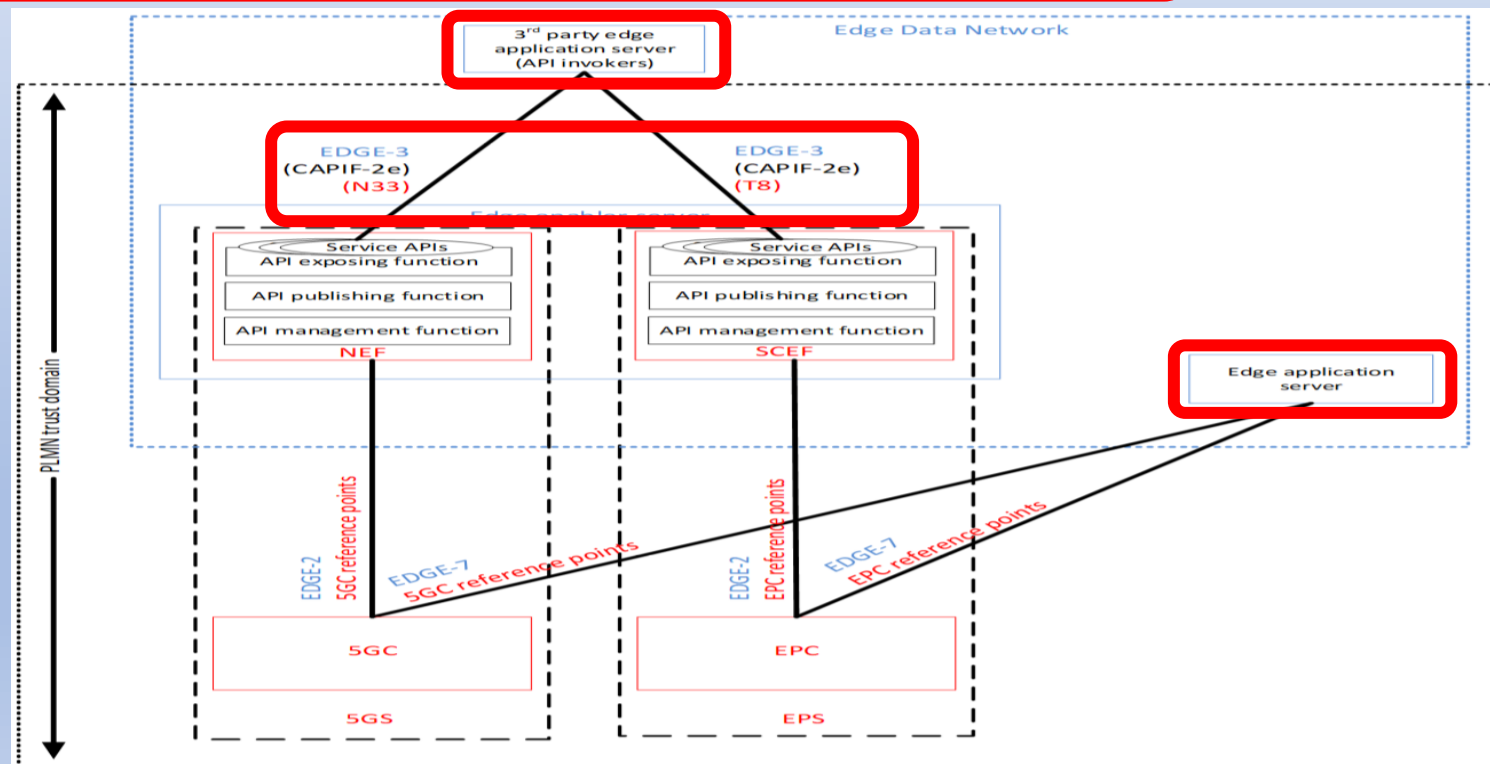

Figure 7.10.1.4.-1: EES and EAS direct interaction with 3GPP Core Network

## 2. ETSI MEC renamed in March 2017 & 3GPP 5G NSA Rel. 15 Mobility - 4

### Selected security enhancements

#### Authentication improvements

2G/3G/4G: authentication done by VPLMN only  
 5G: both in VPLMN and HPLMN  
 5G AKA for 3GPP and non-3GPP access  
 EAP-AKA' for non-3GPP access only

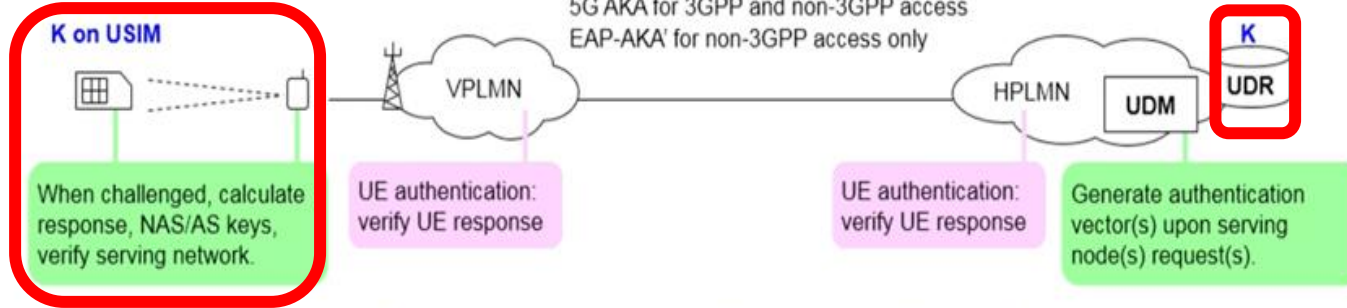

#### Identity protection improvements

2G/3G/4G: occasionally network asks UE to send permanent id (IMSI) unencrypted over the air  
 5G: permanent id (SUPI) never sent unencrypted over the air interface

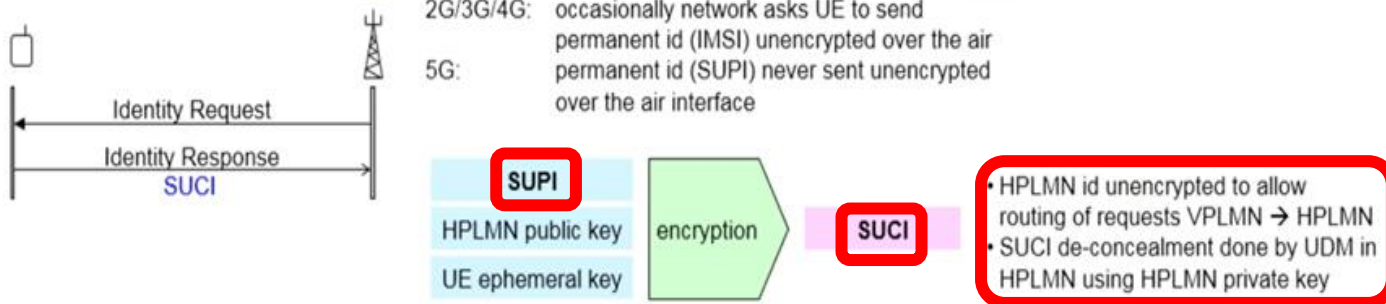

|             |                                      |
|-------------|--------------------------------------|
| <b>SUCI</b> | Subscription Concealed Identifier    |
| <b>SUPI</b> | Subscription Permanent Identifier    |
| UDR         | Unified Data Repository              |
| USIM        | Universal Subscriber Identity Module |

AKA Authentication and Key Agreement  
 AS Access Stratum  
 EAP Extensible Authentication Protocol  
 IMSI International Mobile Subscriber Identity  
 NAS Non-Access Stratum

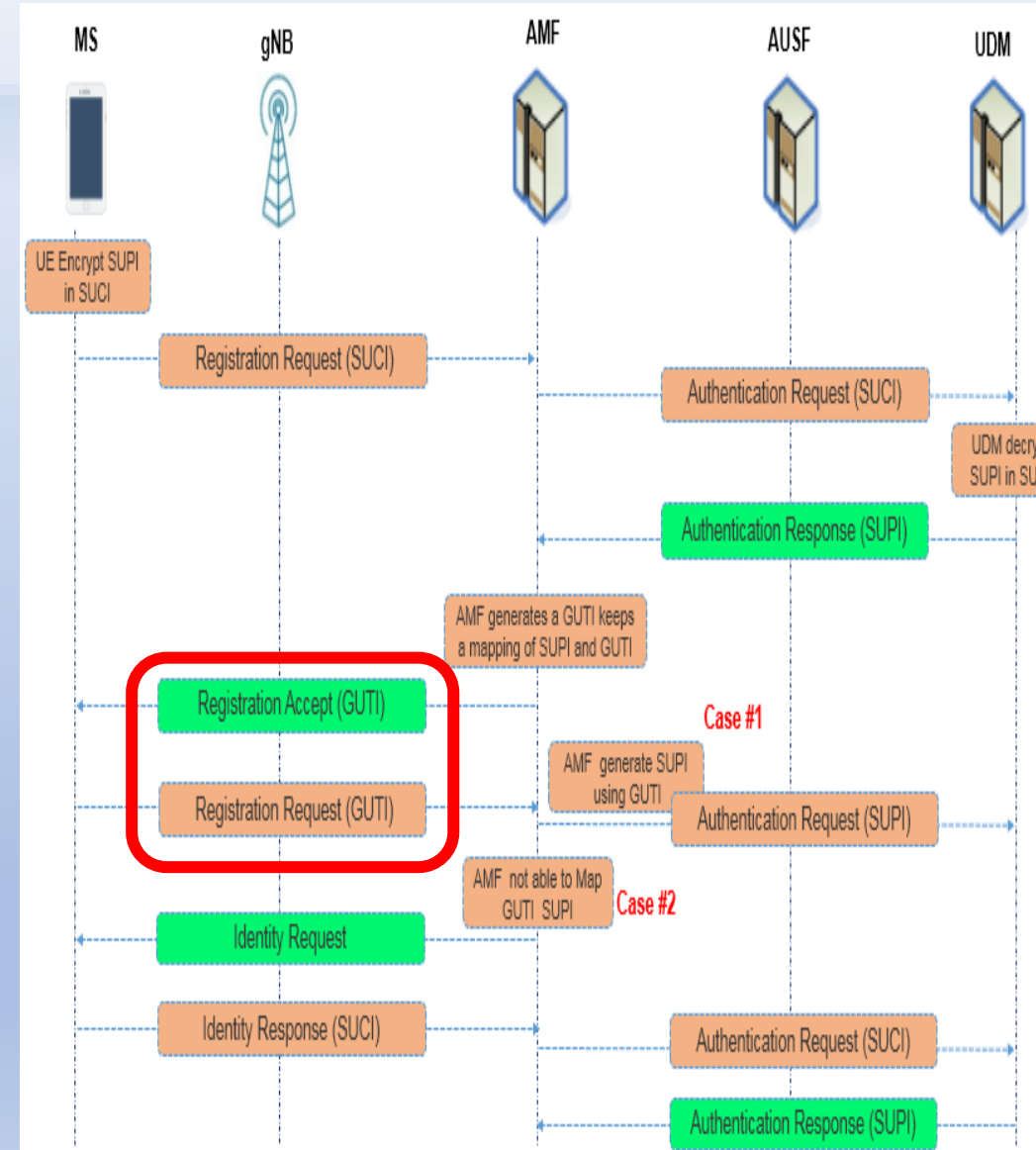



# GSMA Operator Platform (OP) Telco Edge Proposal

## User to Network Interface - UNI

**User-Network Interface (UNI):** enables the User Client (UC) hosted in the UE to communicate with the OP.

1. The primary function of the UNI is to enable a User Client to interact with the OP, to enable the matching of an Application Client with an Application Instance on a Cloudlet.

2. User Client should be capable of being implemented on User Equipment SW, e.g. as an SDK or OS add-on.

3. The UNI shall allow the User Client to discover the existence of an Edge Cloud service.

4. The OP's UNI shall allow the User client registration process with the Operator Platform SRM.

## Federation Broker Role for Federation and Platform Interconnection

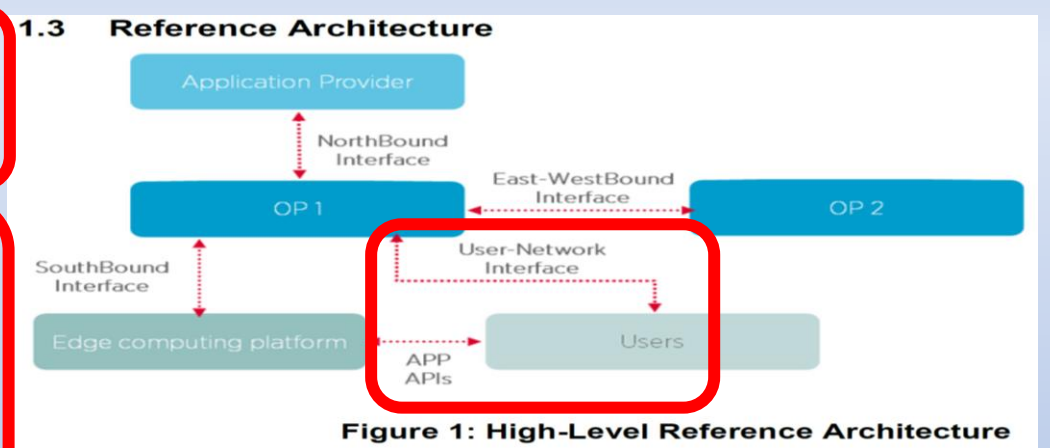

Figure 1: High-Level Reference Architecture

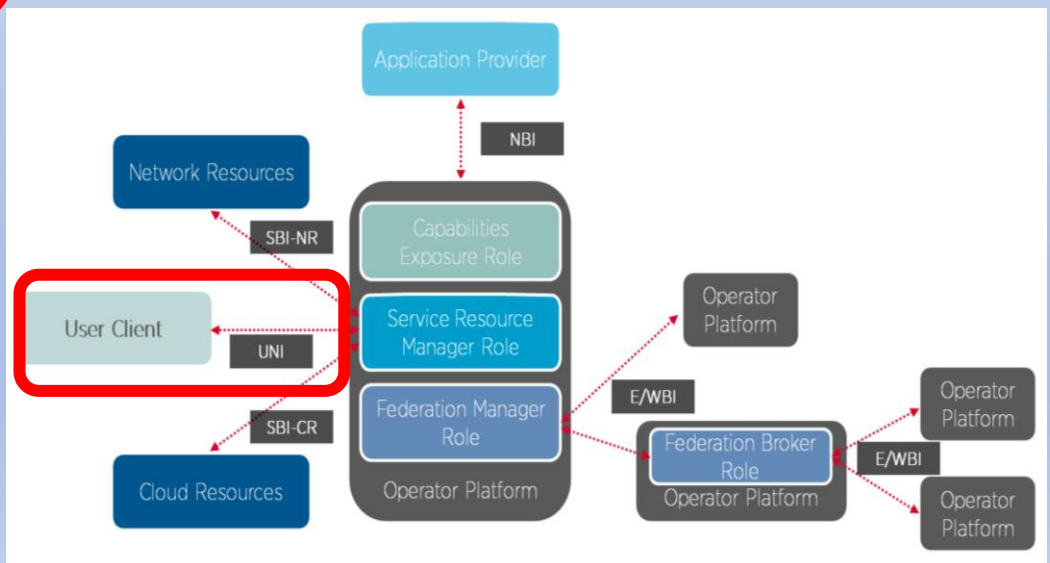

Figure 2: OP Roles and Interfaces Reference Architecture

# ETSI MEC use of Federation Broker enabling Edge Services across MEC System

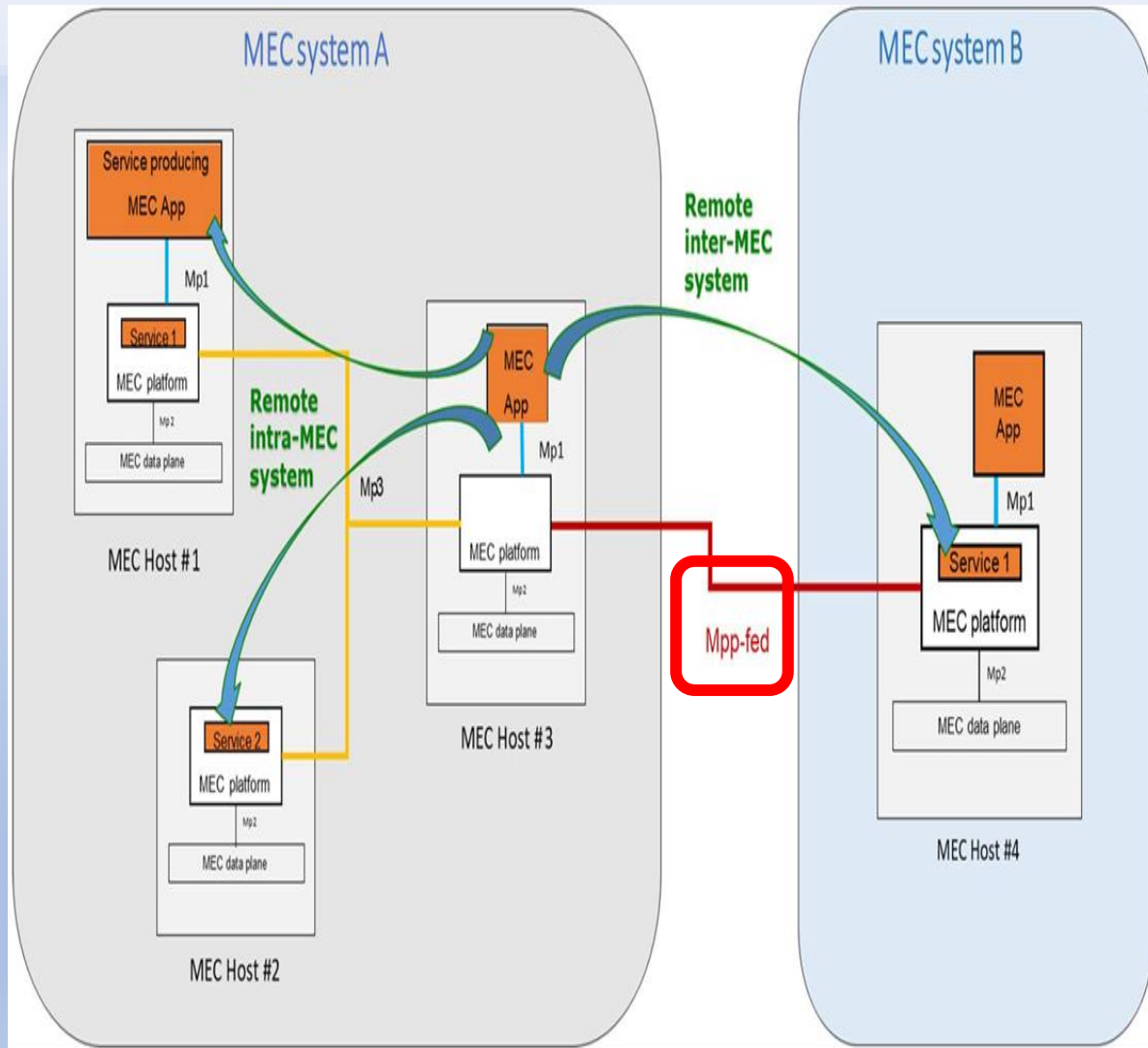

Fig. 6.5.2-1: MEC Federation Scenario enabling Edge Service consumption across MEC Systems.

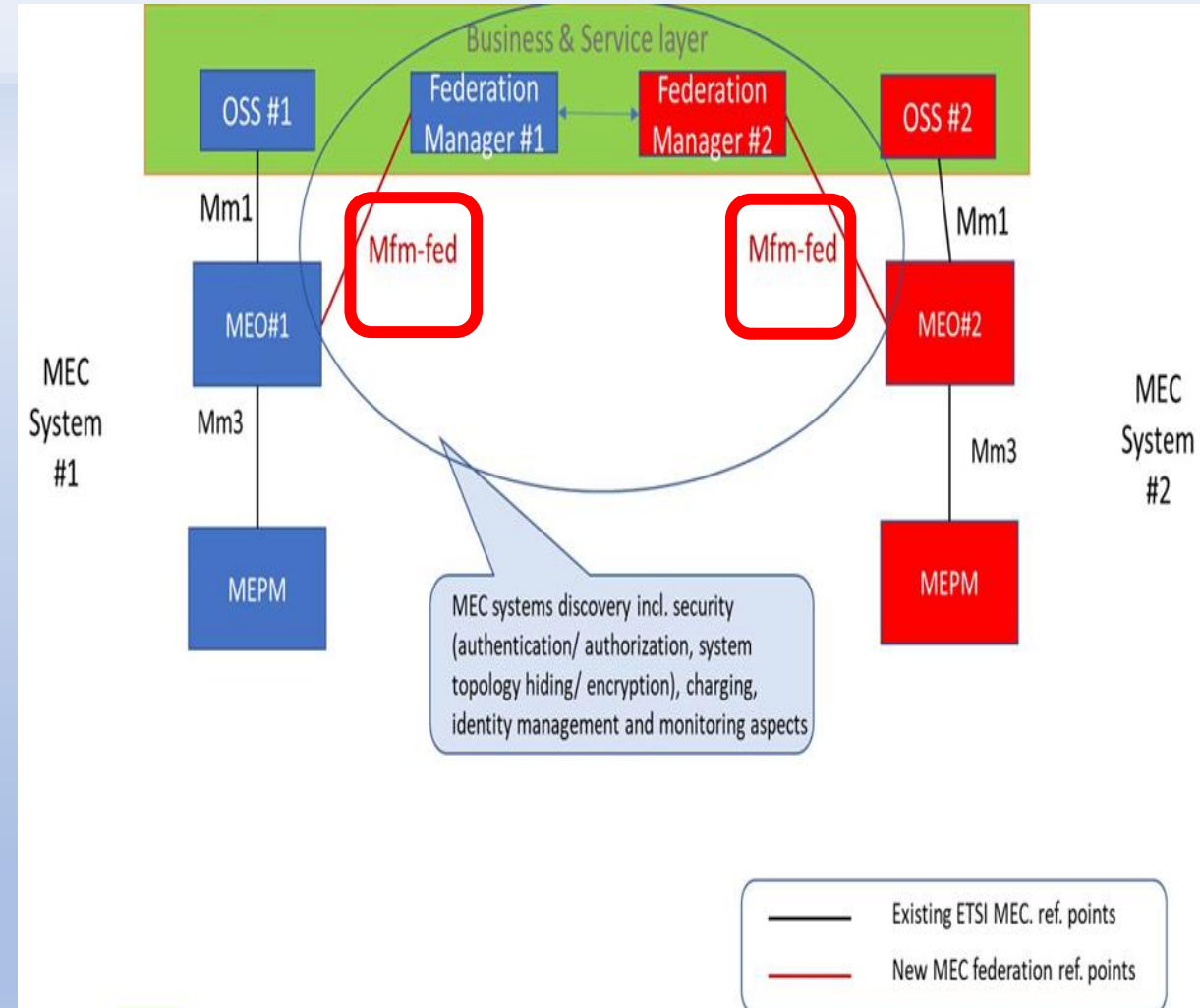

Figure 6.3.2-1: The proposed federation management reference point Mfm-fed connecting a MEC systems MEO with a Federation Manager. In this implementation variant we consider a Federation Manager per each MEC system.

# NBI for E2E Service Management in ETSI ZSM

Figure 4-2 illustrates the set of technology domains considered in the present document. In deployments, there may be additional technology domains. Clause 6 documents the Northbound Interfaces of Management domains based on different technologies.

The NBIs of the E2E Service Management domain are to be defined.

**One candidate: TM Forum Interfaces.**

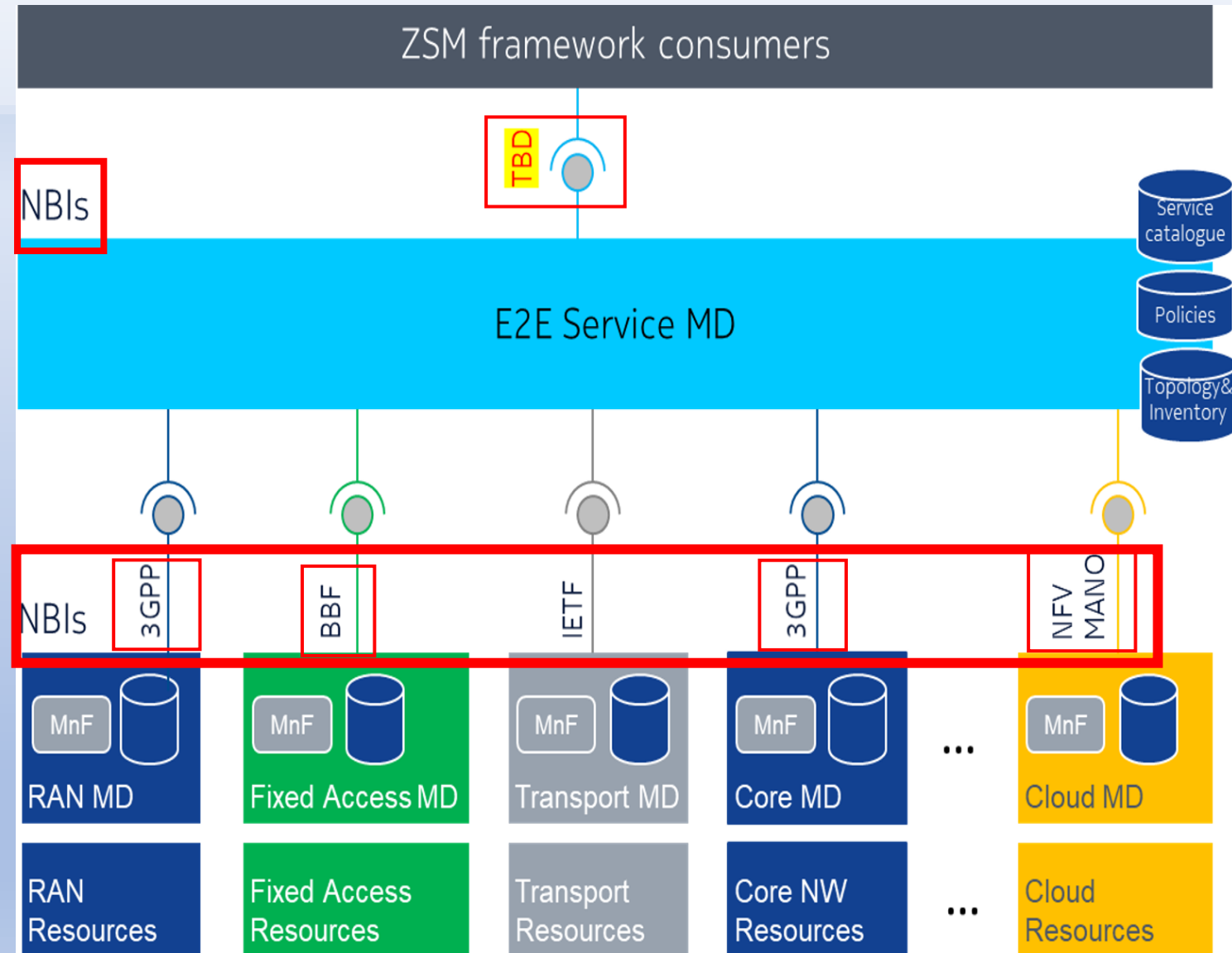

Figure 4-2: Domain NBIs consumed during the Management of the Lifecycle of E2E Services



# IoT

## oneM2M Service Layer (SL) - Horizontal Architecture providing a Common Framework for IoT,

oneM2M has identified a **Set of Common Functionalities**, that are **applicable to all the IoT domains**.

Think of these **functions as a large toolbox with special tools to solve a number of IoT problems across many different domains**. The oneM2M CSFs are applicable to different IoT UCs in different industry domains.

oneM2M has standardized how these Functions are being executed, i.e. it has defined Uniform APIs to access these Functions.

Figure 6.2.0-1 shows a grouping of these Functions into a few different scopes.

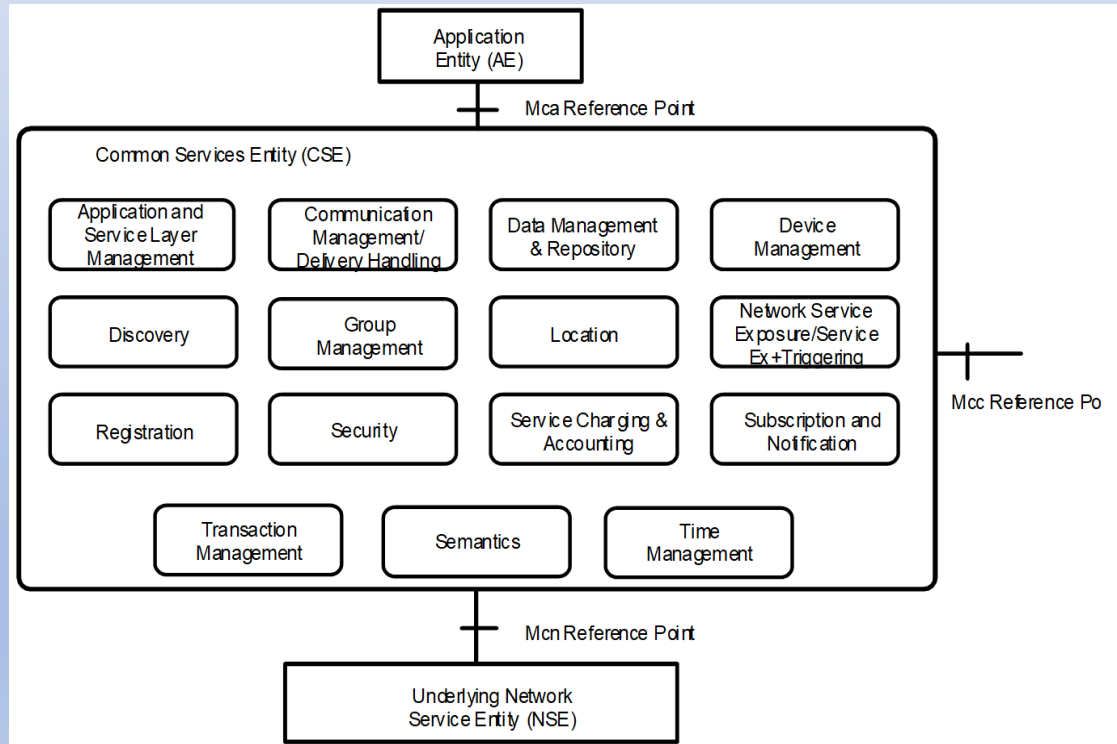

**Fig. 6.2.0-1: Common Service Functions**

## SAREF - Smart Applications REFERENCE Ontology

SAREF is the Reference Ontology for Smart Applications and contains recurring concepts that are used in several Domains. SAREF has a close relation with the oneM2M Base Ontology, for which a mapping is defined in clause 5.

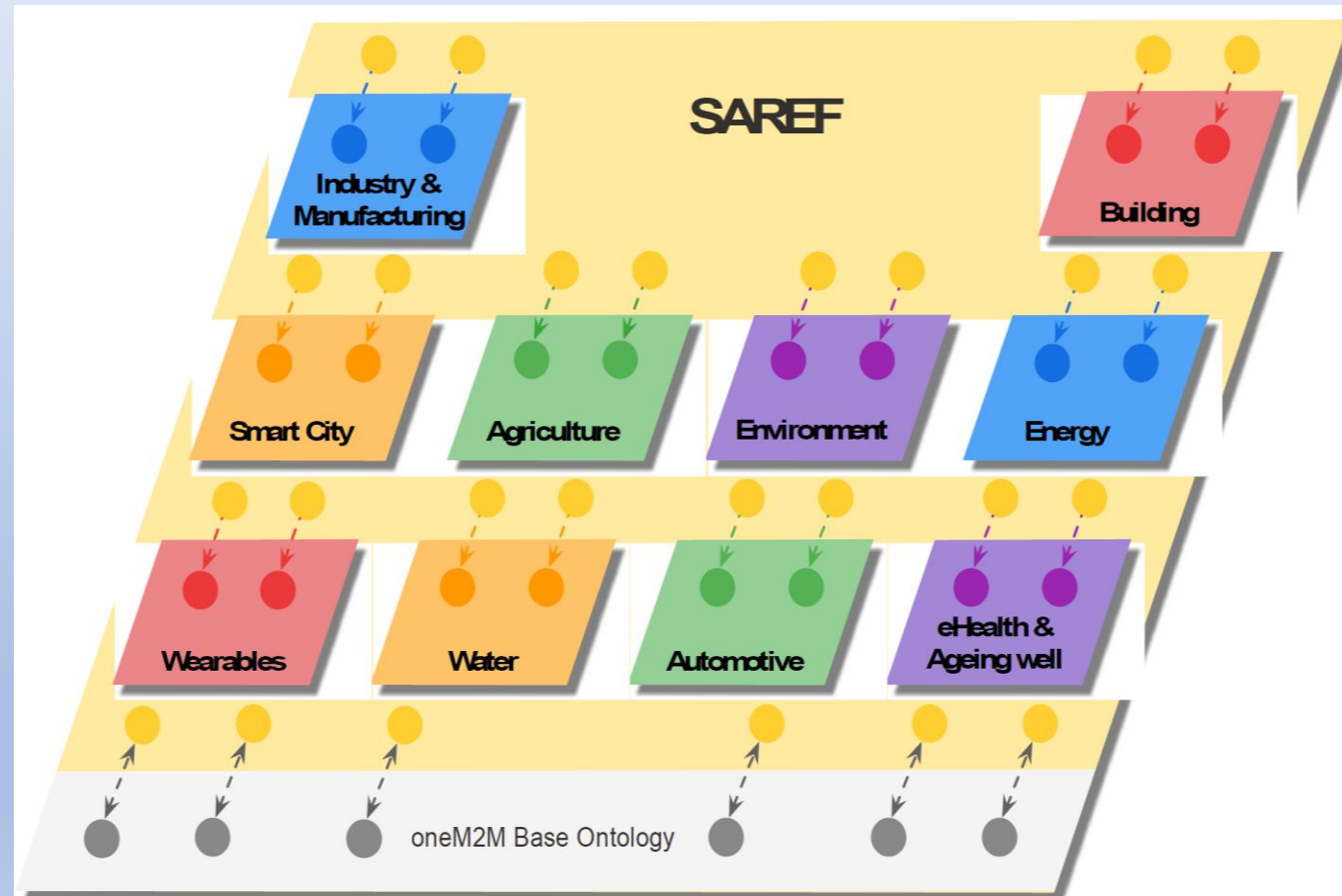

**Figure 11: SAREF and its extensions**



### 3.2 5GS Network Capabilities & MEC Integration - 1: Management Host & System Level

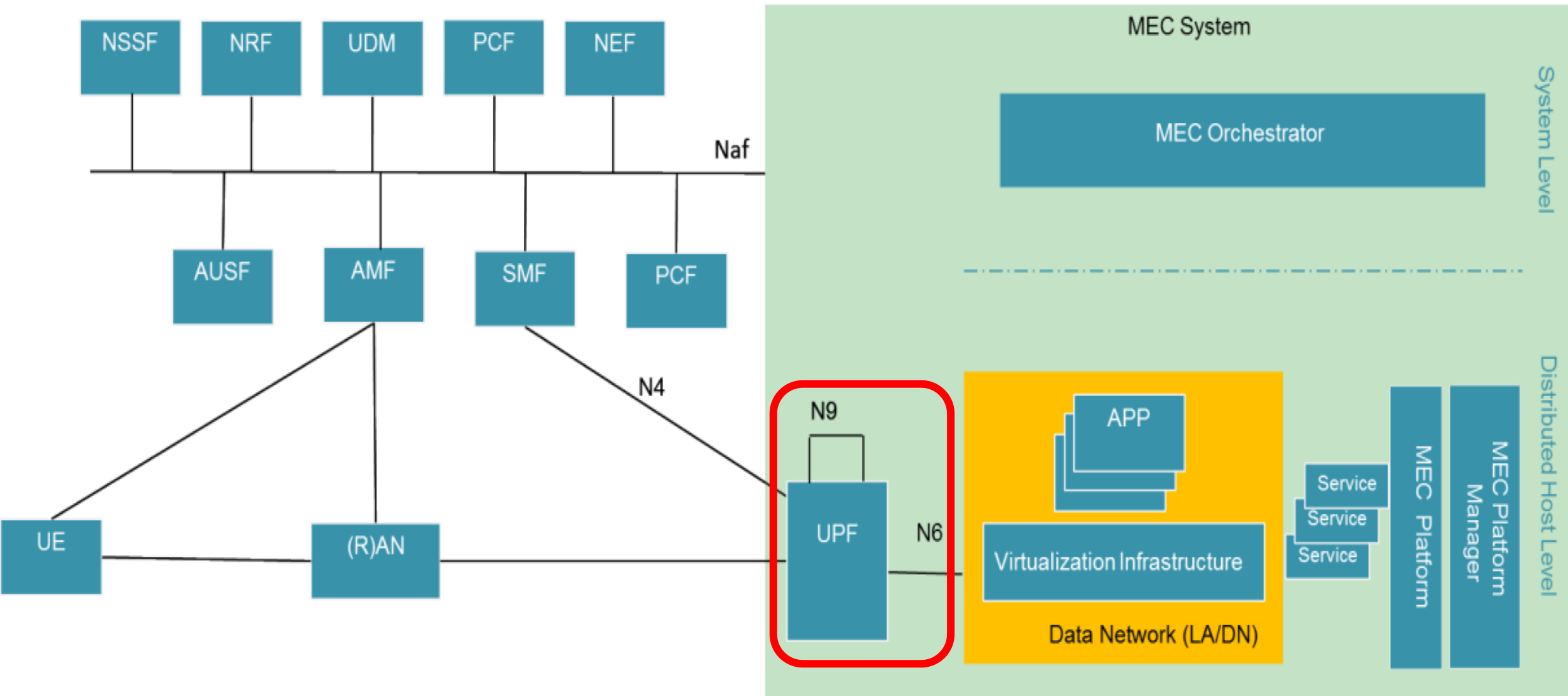

Figure 2. Integrated MEC deployment in 5G network

### 3.4 3GPP EDGEAPP & ETSI MEC SW for developing MEC Applications - 8 MEC in LADN

1. MEC & the local UPF collocated with the eNB/gNB Base Station
2. MEC collocated with a Transmission Node, possibly with a local UPF
3. MEC & the local UPF collocated with a Network Aggregation Point
4. MEC collocated with the CN Functions (i.e. in the same DC)

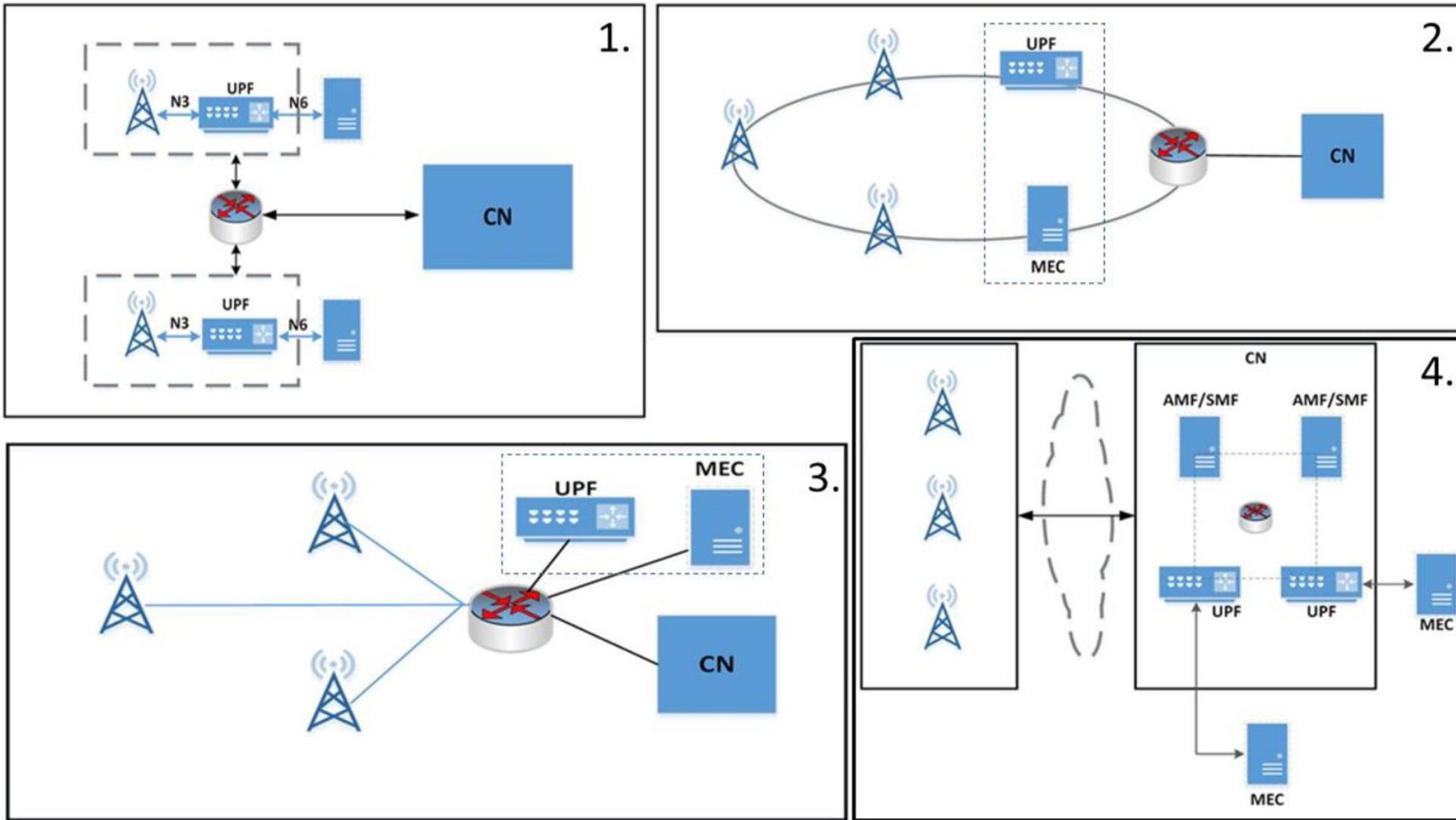

Figure 3. Examples of the physical deployment of MEC.

#### A.2.3 Option 3. Use of LADN

Edge computing services can be provided via Edge-dedicated Data Networks deployed as LADNs. The PLMN supports edge computing services in the EDN service areas with a subset of services by the service area corresponding to the respective LADN DNNs or LADN DNN and subset of Tracking Areas corresponding to the LADN service area. The LADN service area is the service area that the Edge Computing is supported. Each individual EAS in the LADN may support the same or smaller service area than the LADN.

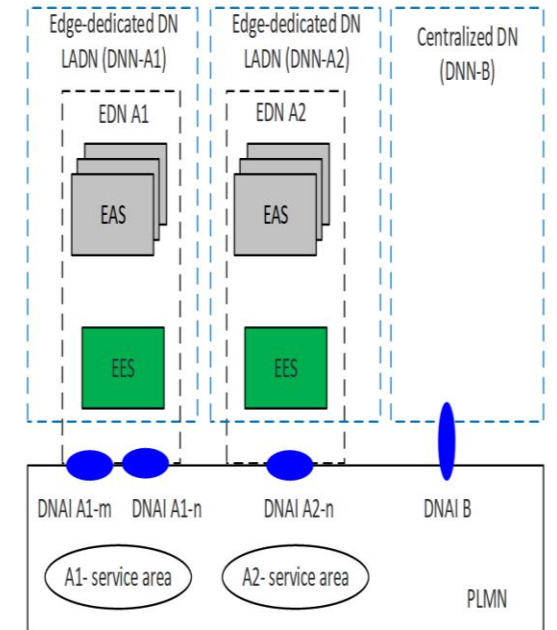
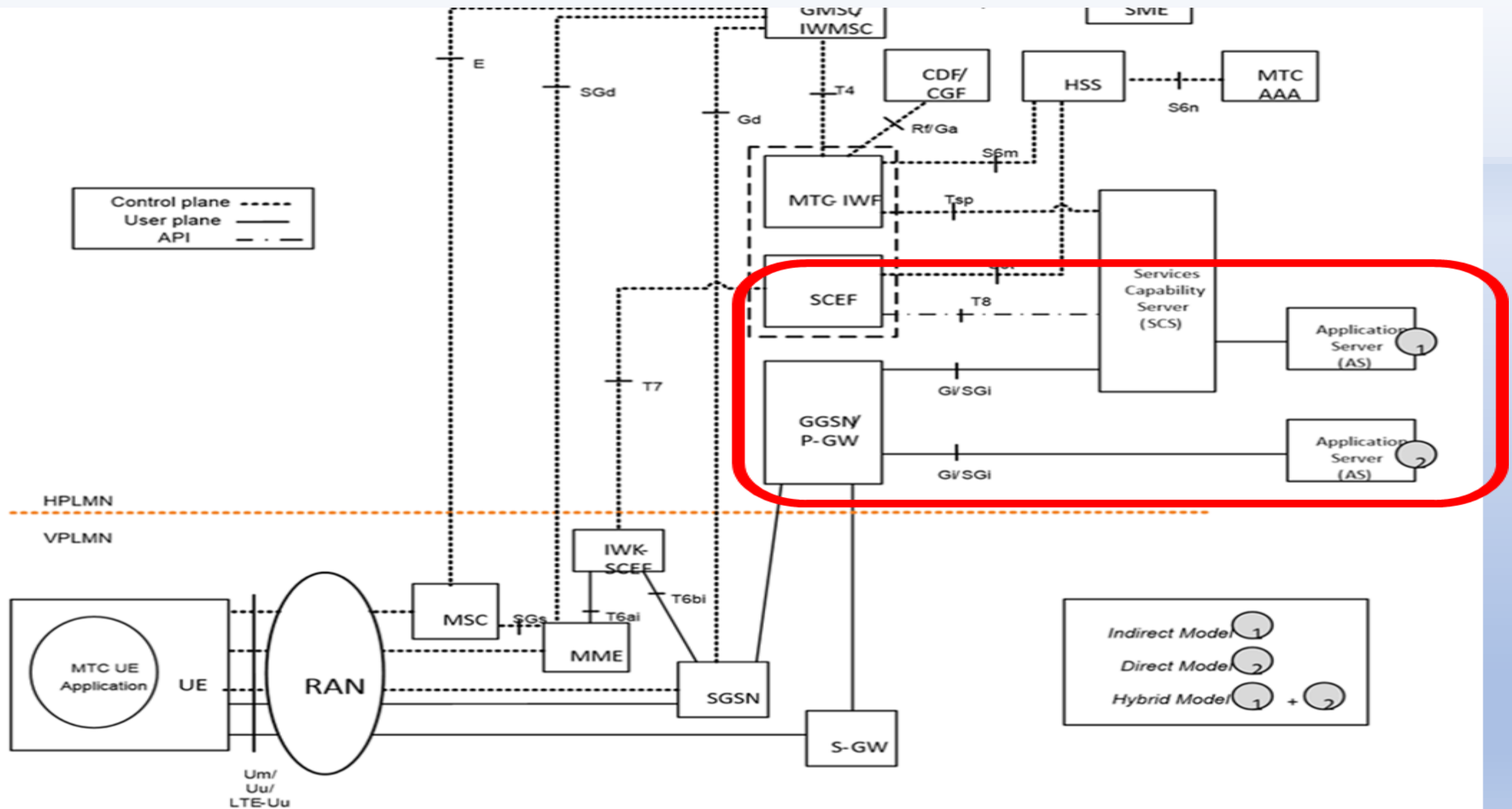

Figure A.2.3-1: Option 3: Use of LADN(s)



**Figure 4.2-1b: 3GPP Architecture for Machine-Type Communication (Roaming)**



## Standardised SST values

Standardized SST values provide a way for establishing global interoperability for slicing so that PLMNs can support the roaming use case more efficiently for the most commonly used Slice/Service Types.

The SSTs which are standardised are in the following Table 5.15.2.2-1.

**Table 5.15.2.2-1 - Standardised SST values**

| Slice/Service type | SST value | Characteristics  |
|--------------------|-----------|--|
| eMBB               | 1         | Slice suitable for the handling of 5G enhanced Mobile Broadband.               |
| URLLC              | 2         | Slice suitable for the handling of ultra- reliable low latency communications. |
| MIoT               | 3         | Slice suitable for the handling of massive IoT.                                |
| V2X                | 4         | Slice suitable for the handling of V2X services.                               |

**NOTE:** The support of all standardised SST values is not required in a PLMN. Services indicated in this table for each SST value can also be supported by means of other SSTs.

# 3GPP 5G SCEF/SCS for IoT Platform integrated with IoT SL across 10 UCs - 1

## Functional mapping between 3GPP and oneM2M

Figure 5.2-1 shows an Architecture and Functional mapping for the 3GPP Trust Domain which describes how oneM2M Functional Entities may access Features and Services that are exposed by 3GPP.

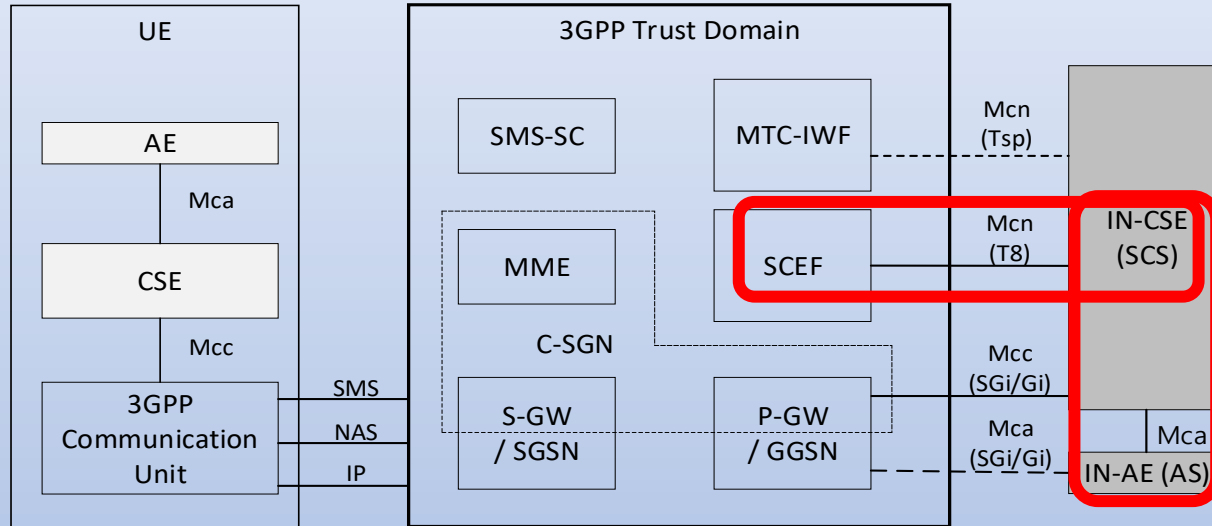

Optionally present oneM2M entity
  oneM2M entity  
 - - - - - Direct connection option not currently supported    - - - - - Tsp is not focus at this TS

**Figure 5.2-1: oneM2M Interfaces to the underlying 3GPP Network**

Several implementation options for the placement of the oneM2M IN-CSE relative to the SCEF and the underlying 3GPP network are envisioned. In all implementations, the SCEF always resides within 3GPP domain.

In some options the IN-CSE and the SCEF are deployed by a MNO and are both part of the operator domain. In other options the SCEF is part of the 3GPP domain and the IN-CSE is not part of the operator domain.

In all options, services within the IN-CSE may access the network services that are exposed by the SCEF via the T8 reference point APIs.

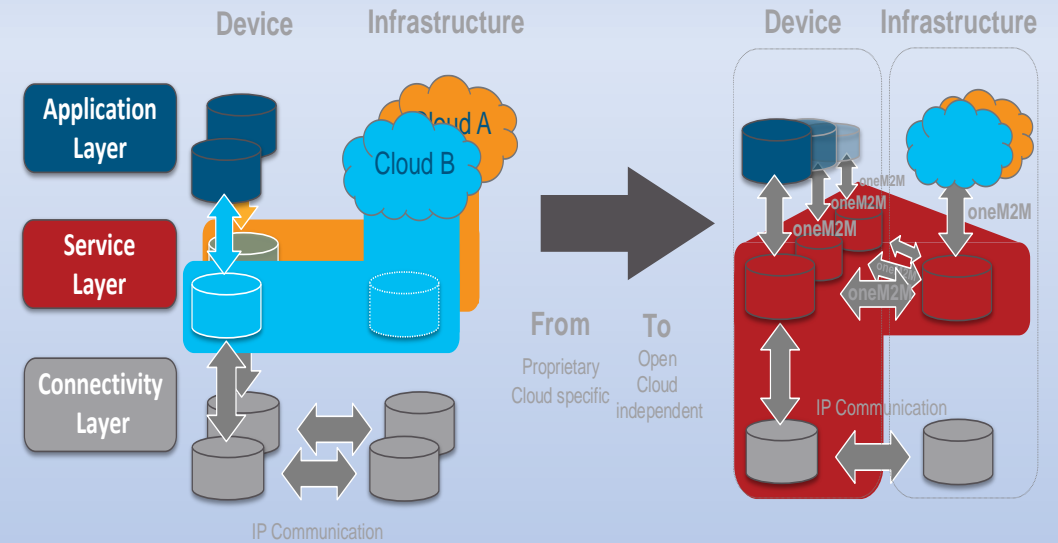

**Figure 5.1.1-3: Cloud provider independent**



**Table 1: 5G User Equipment (UE) Service Access Identities Configuration**

| Access Identity number  | UE configuration   |
|---|--|
| 0   | UE is not configured with any parameters from this table |
| 1 (NOTE 1)  | UE is configured for Multimedia Priority Service (MPS).  |
| 2 (NOTE 2)  | UE is configured for Mission Critical Service (MCS).     |
| 3   | UE for which Disaster Condition applies (note 4)         |
| 4-10  | Reserved for future use                                  |
| 11 (NOTE 3)   | Access Class 11 is configured in the UE.                 |
| 12 (NOTE 3)   | Access Class 12 is configured in the UE.                 |
| 13 (NOTE 3)   | Access Class 13 is configured in the UE.                 |
| 14 (NOTE 3)   | Access Class 14 is configured in the UE.                 |
| 15 (NOTE 3)   | Access Class 15 is configured in the UE.                 |
| <p>NOTE 1: Access Identity 1 is used by UEs configured for MPS, in the PLMNs where the configuration is valid. The PLMNs where the configuration is valid are HPLMN, PLMNs equivalent to HPLMN, and visited PLMNs of the home country.<br/>Access Identity 1 is also valid when the UE is explicitly authorized by the network based on specific configured PLMNs inside and outside the home country.</p> <p>NOTE 2: Access Identity 2 is used by UEs configured for MCS, in the PLMNs where the configuration is valid. The PLMNs where the configuration is valid are HPLMN or PLMNs equivalent to HPLMN and visited PLMNs of the home country. Access Identity 2 is also valid when the UE is explicitly authorized by the network based on specific configured PLMNs inside and outside the home country.</p> <p>NOTE 3: Access Identities 11 and 15 are valid in Home PLMN only if the EHPLMN list is not present or in any EHPLMN. Access Identities 12, 13 and 14 are valid in Home PLMN and visited PLMNs of home country only. For this purpose, the home country is defined as the country of the MCC part of the IMSI.</p> <p>NOTE 4: The configuration is valid for PLMNs that indicate to potential Disaster Inbound Roamers that the UEs can access the PLMN. See clause 6.31.</p> |  |

## Table 2: 5G User Equipment (UE) Service Access Categories Configuration

| Access Category number   | Conditions related to UE  | Type of access attempt   |
|--|---|--|
| 0  | All   | MO signalling resulting from paging                                |
| 1 (NOTE 1)   | UE is configured for delay tolerant service and subject to access control for Access Category 1, which is judged based on relation of UE's HPLMN and the selected PLMN. | All except for Emergency, or MO exception data                     |
| 2  | All   | Emergency  |
| 3  | All except for the conditions in Access Category 1.   | MO signalling on NAS level resulting from other than paging        |
| 4  | All except for the conditions in Access Category 1.   | MIMTEL voice (NOTE 3)  |
| 5  | All except for the conditions in Access Category 1.   | MIMTEL video   |
| 6  | All except for the conditions in Access Category 1.   | SMS  |
| 7  | All except for the conditions in Access Category 1.   | MO data that do not belong to any other Access Categories (NOTE 4) |
| 8  | All except for the conditions in Access Category 1  | MO signalling on RRC level resulting from other than paging        |
| 9  | All except for the conditions in Access Category 1  | MO IMS registration related signalling (NOTE 5)                    |
| 10 (NOTE 6)  | All   | MO exception data  |
| 11-31  |   | Reserved standardized Access Categories                            |
| 32-63 (NOTE 2)   | All   | Based on operator classification                                   |
| <p><b>NOTE 1:</b> The barring parameter for Access Category 1 is accompanied with information that define whether Access Category applies to UEs within one of the following categories:</p> <ul style="list-style-type: none"> <li>a) UEs that are configured for delay tolerant service;</li> <li>b) UEs that are configured for delay tolerant service and are neither in their HPLMN nor in a PLMN that is equivalent to it;</li> <li>c) UEs that are configured for delay tolerant service and are neither in the PLMN listed as most preferred PLMN of the country where the UE is roaming in the operator-defined PLMN selector list on the SIM/USIM, nor in their HPLMN nor in a PLMN that is equivalent to their HPLMN.</li> </ul> <p>When a UE is configured for EAB, the UE is also configured for delay tolerant service. In case a UE is configured both for EAB and for EAB override, when upper layer indicates to override Access Category 1, then Access Category 1 is not applicable.</p> <p><b>NOTE 2:</b> When there are an Access Category based on operator classification and a standardized Access Category to both of which an access attempt can be categorized, and the standardized Access Category is neither 0 nor 2, the UE applies the Access Category based on operator classification. When there are an Access Category based on operator classification and a standardized Access Category to both of which an access attempt can be categorized, and the standardized Access Category is 0 or 2, the UE applies the standardized Access Category.</p> <p><b>NOTE 3:</b> Includes Real-Time Text (RTT).</p> <p><b>NOTE 4:</b> Includes IMS Messaging.</p> <p><b>NOTE 5:</b> Includes IMS registration related signalling, e.g. IMS initial registration, re-registration, and subscription refresh.</p> <p><b>NOTE 6:</b> Applies to access of a NB-IoT-capable UE to a NB-IOT cell connected to 5GC when the UE is authorized to send exception data.</p> |   |  |

### Table 3: Performance Requirements for High Data Rate and Traffic Density Scenarios

|   | Scenario                    | Experienced data rate (DL)          | Experienced data rate (UL)               | Area traffic capacity (DL)          | Area traffic capacity (UL)          | Overall user density                           | Activity factor | UE speed   | Coverage                                 |
|---|-----------------------------|-------------------------------------|--|-------------------------------------|-------------------------------------|--|-----------------|--|--|
| 1 | Urban macro                 | 50 Mbit/s                           | 25 Mbit/s                                | 100 Gbit/s/km <sup>2</sup> (note 4) | 50 Gbit/s/km <sup>2</sup> (note 4)  | 10 000/km <sup>2</sup>                         | 20 %            | Pedestrians and users in vehicles (up to 120 km/h)                   | Full network (note 1)                    |
| 2 | Rural macro                 | 50 Mbit/s                           | 25 Mbit/s                                | 1 Gbit/s/km <sup>2</sup> (note 4)   | 500 Mbit/s/km <sup>2</sup> (note 4) | 100/km <sup>2</sup>                            | 20 %            | Pedestrians and users in vehicles (up to 120 km/h)                   | Full network (note 1)                    |
| 3 | Indoor hotspot              | 1 Gbit/s                            | 500 Mbit/s                               | 15 Tbit/s/km <sup>2</sup>           | 2 Tbit/s/km <sup>2</sup>            | 250 000/km <sup>2</sup>                        | note 2          | Pedestrians  | Office and residential (note 2) (note 3) |
| 4 | Broadband access in a crowd | 25 Mbit/s                           | 50 Mbit/s                                | [3,75] Tbit/s/km <sup>2</sup>       | [7,5] Tbit/s/km <sup>2</sup>        | [500 000]/km <sup>2</sup>                      | 30 %            | Pedestrians  | Confined area                            |
| 5 | Dense urban                 | 300 Mbit/s                          | 50 Mbit/s                                | 750 Gbit/s/km <sup>2</sup> (note 4) | 125 Gbit/s/km <sup>2</sup> (note 4) | 25 000/km <sup>2</sup>                         | 10 %            | Pedestrians and users in vehicles (up to 60 km/h)                    | Downtown (note 1)                        |
| 6 | Broadcast-like services     | Maximum 200 Mbit/s (per TV channel) | N/A or modest (e.g. 500 kbit/s per user) | N/A                                 | N/A                                 | [15] TV channels of [20 Mbit/s] on one carrier | N/A             | Stationary users, pedestrians and users in vehicles (up to 500 km/h) | Full network (note 1)                    |
| 7 | High-speed train            | 50 Mbit/s                           | 25 Mbit/s                                | 15 Gbit/s/train                     | 7,5 Gbit/s/train                    | 1 000/train                                    | 30 %            | Users in trains (up to 500 km/h)                                     | Along railways (note 1)                  |
| 8 | High-speed vehicle          | 50 Mbit/s                           | 25 Mbit/s                                | [100] Gbit/s/km <sup>2</sup>        | [50] Gbit/s/km <sup>2</sup>         | 4 000/km <sup>2</sup>                          | 50 %            | Users in vehicles (up to 250 km/h)                                   | Along roads (note 1)                     |
| 9 | Airplanes connectivity      | 15 Mbit/s                           | 7,5 Mbit/s                               | 1,2 Gbit/s/plane                    | 600 Mbit/s/plane                    | 400/plane                                      | 20 %            | Users in airplanes (up to 1 000 km/h)                                | (note 1)                                 |

NOTE 1: For users in vehicles, the UE can be connected to the network directly, or via an on-board moving base station.

NOTE 2: A certain traffic mix is assumed; only some users use services that require the highest data rates [2].

NOTE 3: For interactive audio and video services, for example, virtual meetings, the required two-way end-to-end latency (UL and DL) is 2-4 ms while the corresponding experienced data rate needs to be up to 8K 3D video [300 Mbit/s] in uplink and downlink.

NOTE 4: These values are derived based on overall user density. Detailed information can be found in [10].

NOTE 5: All the values in this table are targeted values and not strict requirements.

# Table 4: Performance Requirements for Horizontal and Vertical Positioning Service Levels

| Positioning service level | Absolute(A) or Relative(R) positioning | Accuracy (95 % confidence level) |                            | Positioning service availability | Positioning service latency | Coverage, environment of use and UE velocity  |   |                        |
|---------------------------|--|----------------------------------|----------------------------|----------------------------------|-----------------------------|---|---|------------------------|
|                           |  | Horizontal Accuracy              | Vertical Accuracy (note 1) |                                  |                             | 5G positioning service area   | 5G enhanced positioning service area (note 2)   |                        |
|                           |  |                                  |                            |                                  |                             |   | Outdoor and tunnels   | Indoor                 |
| 1                         | A                                      | 10 m                             | 3 m                        | 95 %                             | 1 s                         | Indoor - up to 30 km/h<br>Outdoor (rural and urban) up to 250 km/h  | NA  | Indoor - up to 30 km/h |
| 2                         | A                                      | 3 m                              | 3 m                        | 99 %                             | 1 s                         | Outdoor (rural and urban) up to 500 km/h for trains and up to 250 km/h for other vehicles   | Outdoor (dense urban) up to 60 km/h<br>Along roads up to 250 km/h and along railways up to 500 km/h | Indoor - up to 30 km/h |
| 3                         | A                                      | 1 m                              | 2 m                        | 99 %                             | 1 s                         | Outdoor (rural and urban) up to 500 km/h for trains and up to 250 km/h for other vehicles   | Outdoor (dense urban) up to 60 km/h<br>Along roads up to 250 km/h and along railways up to 500 km/h | Indoor - up to 30 km/h |
| 4                         | A                                      | 1 m                              | 2 m                        | 99,9 %                           | 15 ms                       | NA  | NA  | Indoor - up to 30 km/h |
| 5                         | A                                      | 0,3 m                            | 2 m                        | 99 %                             | 1 s                         | Outdoor (rural) up to 250 km/h  | Outdoor (dense urban) up to 60 km/h<br>Along roads and along railways up to 250 km/h                | Indoor - up to 30 km/h |
| 6                         | A                                      | 0,3 m                            | 2 m                        | 99,9 %                           | 10 ms                       | NA  | Outdoor (dense urban) up to 60 km/h   | Indoor - up to 30 km/h |
| 7                         | R                                      | 0,2 m                            | 0,2 m                      | 99 %                             | 1 s                         | Indoor and outdoor (rural, urban, dense urban) up to 30 km/h<br>Relative positioning is between two UEs within 10 m of each other or between one UE and 5G positioning nodes within 10 m of each other (note 3) |   |                        |

**NOTE 1:** The objective for the vertical positioning requirement is to determine the floor for indoor use cases and to distinguish between superposed tracks for road and rail use cases (e.g. bridges).

**NOTE 2:** Indoor includes location inside buildings such as offices, hospital, industrial buildings.

**NOTE 3:** 5G positioning nodes are infrastructure equipment deployed in the service area to enhance positioning capabilities (e.g. beacons deployed on the perimeter of a rendezvous area or on the side of a warehouse).



**Table 5: UE to Satellite Propagation Delay**

|     | UE to satellite Delay [ms] |     | One-Way Max propagation delay [ms] |
|-----|----------------------------|-----|------------------------------------|
|     | Min                        | Max |                                    |
| LEO | 3                          | 15  | 30                                 |
| MEO | 27                         | 43  | 90                                 |
| GEO | 120                        | 140 | 280                                |

**Table 6: Performance Requirements for Satellite Access**

| Scenario                        | Experienced data rate (DL) | Experienced data rate (UL) | Area traffic capacity (DL) (note 1) | Area traffic capacity (UL) (note 1) | Overall user density  | Activity factor | UE speed         | UE type          |
|---------------------------------|----------------------------|----------------------------|-------------------------------------|-------------------------------------|-----------------------|-----------------|------------------|------------------|
| Pedestrian (note 2)             | [1] Mbit/s                 | [100] kbit/s               | 1,5 Mbit/s/km <sup>2</sup>          | 150 kbit/s/km <sup>2</sup>          | [100]/km <sup>2</sup> | [1,5] %         | Pedestrian       | Handheld         |
| Public safety                   | [3,5] Mbit/ss              | [3,5] Mbit/s               | TBD                                 | TBD                                 | TBD                   | N/A             | 100 km/h         | Handheld         |
| Vehicular connectivity (note 3) | 50 Mbit/s                  | 25 Mbit/s                  | TBD                                 | TBD                                 | TBD                   | 50 %            | Up to 250 km/h   | Vehicle mounted  |
| Airplanes connectivity (note 4) | 360 Mbit/s/ plane          | 180 Mbit/s/ plane          | TBD                                 | TBD                                 | TBD                   | N/A             | Up to 1000 km/h  | Airplane mounted |
| Stationary                      | 50 Mbit/s                  | 25 Mbit/s                  | TBD                                 | TBD                                 | TBD                   | N/A             | Stationary       | Building mounted |
| Narrowband IoT connectivity     | [2] kbit/s                 | [10] kbit/s                | 8 kbit/s/km <sup>2</sup>            | 40 kbit/s/km <sup>2</sup>           | [400]/km <sup>2</sup> | [1] %           | [Up to 100 km/h] | IoT              |

Note 1: Area capacity is averaged over a satellite beam.

Note 2: Data rates based on Extreme long-range coverage target values in clause 6.17.2. User density based on rural area in Table 7.1-1.

Note 3: Based on Table 7.1-1

Note 4: Based on an assumption of 120 users per plane 15/7.5 Mbit/s data rate and 20 % activity factor per user

Note 5: All the values in this table are targeted values and not strict requirements.

Note 6: Performance requirements for all the values in this table should be analyzed independently for each scenario.



**Table 7: Performance Requirements for Highly Reliable Machine Type Communication**

| Profile                     | Characteristic parameter                              |   |                             |            |           | Influence quantity  |                   |                   |                 |  |  |
|-----------------------------|---|---|-----------------------------|------------|-----------|---------------------|-------------------|-------------------|-----------------|--|--|
|                             | Communication service availability: target value in % | Communication service reliability (Mean Time Between Failure) | End-to-end latency: maximum | Bit rate   | Direction | Message Size [byte] | Transfer Interval | Survival Time     | UE speed (km/h) | # of UEs connection                        | Service Area   |
| Medical monitoring (note 2) | > 99,9999   | <1 year (>> 1 month)  | < 100 ms                    | < 1 Mbit/s | Uplink    | ~ 1000              | 50 ms             | Transfer Interval | < 500           | 10/km <sup>2</sup> to 1000/km <sup>2</sup> | Country wide including rural areas and deep indoor. (note 1) |

NOTE 1: "deep indoor" term is meant to be places like e.g. elevators, building's basement, underground parking lot, ...

NOTE 2: These performance requirements aim energy-efficient transmissions performed using a device powered with a 3.3V battery of capacity < 1000 mAh that can last at least 1 month without recharging and whereby the peak current for transmit operations stays below 50 mA.

**Table 8 KPI Table for additional High Data Rate and Low Latency Service**

| Use Cases  | Characteristic parameter (KPI)  |  |   |          |                          |  |
|--|---|--|---|----------|--------------------------|--|
|  | max allowed end-to-end latency  | Service bit rate: user-experienced data rate   | Reliability                                       | # of UEs | UE Speed                 | Service Area (note 2)  |
| Cloud/Edge/Split Rendering (note 1)                        | 5 ms (i.e. UL+DL between UE and the interface to data network) (note 4) | 0,1 to [1] Gbit/s supporting visual content (e.g. VR based or high definition video) with 4K, 8K resolution and up to 120 frames per second content. | 99,99 % in uplink and 99,9 % in downlink (note 4) | -        | Stationary or Pedestrian | Countrywide  |
| Gaming or Interactive Data Exchanging (note 3)             | 10ms (note 4)   | 0,1 to [1] Gbit/s supporting visual content (e.g. VR based or high definition video) with 4K, 8K resolution and up to 120 frames per second content. | 99,99 % (note 4)                                  | ≤ [10]   | Stationary or Pedestrian | 20 m x 10 m; in one vehicle (up to 120 km/h) and in one train (up to 500 km/h) |
| Consumption of VR content via tethered VR headset (note 6) | [5 to 10] ms (note 5)   | 0,1 to [10] Gbit/s (note 5)  | [99,99 %]   | -        | Stationary or Pedestrian | -  |

NOTE 1: Unless otherwise specified, all communication via wireless link is between UEs and network node (UE to network node and/or network node to UE) rather than direct wireless links (UE to UE).

NOTE 2: Length x width (x height).

NOTE 3: Communication includes direct wireless links (UE to UE).

NOTE 4: Latency and reliability KPIs can vary based on specific use case/architecture, e.g. for cloud/edge/split rendering, and may be represented by a range of values.

NOTE 5: The decoding capability in the VR headset and the encoding/decoding complexity/time of the stream will set the required bit rate and latency over the direct wireless link between the tethered VR headset and its connected UE, bit rate from 100 Mbit/s to [10] Gbit/s and latency from 5 ms to 10 ms.

NOTE 6: The performance requirement is valid for the direct wireless link between the tethered VR headset and its connected UE.

## Table 9: Key Performance for UE to Network Relaying

| Scenario                 | Max. data rate (DL) | Max. data rate (UL) | End-to-end latency (note 7) | Area traffic capacity (DL)         | Area traffic capacity (UL)         | Area user density                   | Area                     | Range of a single hop (note 8)      | Estimated number of hops |
|--------------------------|---------------------|---------------------|-----------------------------|------------------------------------|------------------------------------|-------------------------------------|--------------------------|-------------------------------------|--------------------------|
| InHome Scenario (note 1) | 1 Gbit/s            | 500 Mbit/s          | 10 ms                       | 5 Gbit/s/home                      | 2 Gbit/s/home                      | 50 devices /house                   | 10 m x 10m – 3 floors    | 10 m indoor                         | 2 to 3                   |
| Factory Sensors (note 2) | 100 kbit/s          | 5 Mbit/s            | 50 ms to 1 s                | 1 Gbit/s /factory                  | 50 Gbit/s /factory                 | 10000 devices /factory              | 100 m x 100 m            | 30 m indoor / metallic              | 2 to 3                   |
| Smart Metering (note 3)  | 100 bytes / 15 mins | 100 bytes / 15 mins | 10 s                        | 200 x 100 bytes / 15 mins /hectare | 200 x 100 bytes / 15 mins /hectare | 200 devices /hectare                | 100 m x 100 m            | > 100 m indoor / deep indoor        | 2 to 5                   |
| Containers (note 4)      | 100 bytes / 15 mins | 100 bytes / 15 mins | 10 s                        | 15000 x 100 bytes / 15 mins /ship  | 15000 x 100 bytes / 15 mins /ship  | 15000 containers /ship              | 400 m x 60 m x 40 m      | > 100 m indoor / outdoor / metallic | 3 to 9                   |
| Freight Wagons           | 100 bytes / 15 mins | 100 bytes / 15 mins | 10 s                        | 200 x 100 bytes / 15 mins /train   | 200 x 100 bytes / 15 mins /train   | 120 wagons /train                   | 1 km                     | > 100 m outdoor / tunnel            | 10 to 15                 |
| Public Safety (note 5)   | 12 Mbit/s           | 12 Mbit/s           | 30 ms                       | 20 Mbit/s /building                | 40 Mbit/s /building                | 30 devices /building                | 100 m x 100 m – 3 floors | > 50 m indoor (floor or stairwell)  | 2 to 4                   |
| Wearables (note 6)       | 10 Mbit/s           | 10 Mbit/s           | 10 ms                       | 20 Mbit/s per 100 m <sup>2</sup>   | 20 Mbit/s per 100 m <sup>2</sup>   | 10 wearables per 100 m <sup>2</sup> | 10 m x 10 m              | 10 m indoor / outdoor               | 1 to 2                   |

NOTE 1: Area traffic capacity is determined by high bandwidth consuming devices (e.g. ultra HD TVs, VR headsets), the number of devices has been calculated assuming a family of 4 members.

NOTE 2: Highest data rate assumes audio sensors with sampling rate of 192 kHz and 24 bits sample size.

NOTE 3: Three meters (gas, water, electricity) per house, medium density of 50 to 70 houses per hectare.

NOTE 4: A large containership with a mix of 20 foot and 40 foot containers is assumed.

NOTE 5: A mix of MCPTT, MCVideo, and MCDATA is assumed. Average 3 devices per firefighter / police officer, of which one video device. Area traffic based on 1080 p, 60 fps is 12 Mbit/s video, with an activity factor of 30% in uplink (30% of devices transmit simultaneously at high bitrate) and 15% in downlink.

NOTE 6: Communication for wearables is relayed via a UE. This relay UE may use a further relay UE.

NOTE 7: End-to-end latency implies that all hops are included.

NOTE 8: 'Metallic' implies an environment with a lot of metal obstructions (e.g. machinery, containers). 'Deep indoor' implies that there may be concrete walls / floors between the devices.

NOTE 9: All the values in this table are example values and not strict requirements.

# Latency needs to support example Use Cases (UCs) from Vertical Industries

| Services/<br>Use cases | Automotive use cases  | Transport, logistics, IoT<br>use cases   | Health and wellness,<br>smart cities use cases   | Media and entertainment  |
|------------------------|---|--|--|--|
| Description            | Expand detectable range beyond on board sensor capability by sharing views or detected objects among traffic participants, coordinate trajectories among vehicles, sharing coarse driving intention, real-time remote operation of vehicles   | Real-time sensing, reporting, feedback, control, remote, asset tracking, monitoring; context-aware services, recommendations at shopping mall, airport   | Live video feed (4K, 8K, 3D for remote healthcare (consultation, monitoring) and assisted surgery, real-time commands to control medical devices for treatment (e.g. medication, surgery); remote monitoring, surveillance and guidance for citizens and law enforcement officers.   | Media production services based on aggregation of various media feeds at servers; real-time peer-to-peer or server-client sharing of data (object information) for collaborative gaming, live streaming at live events |
| Latency                | <p>For mid/long-term environment modelling (dynamic high-definition digital map update):<br/>Not critical (100 ms end-to-end)</p> <p>For short term environment modelling (sensor sharing):<br/>&lt;20 ms end-to-end</p> <p>For cooperation (coordinated control):</p> <ul style="list-style-type: none"> <li>- &lt;3 ms end-to-end for platooning</li> <li>- &lt;10 ms end-to-end for cooperative manoeuvres</li> <li>- &lt;100 ms end-to-end for coarse driving intention</li> </ul> <p>For remote vehicle operation:<br/>10-30 ms end-to-end</p> | <p>For massive connectivity for time-critical sensing and feedback:<br/>&lt;30 ms end-to-end.</p> <p>For remote drone operation and cooperative farm machinery:<br/>10-30 ms end-to-end</p> <p>Real-time control for discrete automation:<br/>≤1 ms end-to-end</p> | <p>For real-time video/telepresence/augmented reality for remote healthcare and assisted surgery, for monitoring and guidance (smart cities):<br/>100 ms end-to-end</p> <p>Real-time command and control for remote medication and surgery:<br/>10-100 ms end-to-end</p> <p>For smart grid:</p> <ul style="list-style-type: none"> <li>- &lt;5 ms end-to-end for transmission/grid backbone,</li> <li>- &lt;50 ms end-to-end for distribution/grid backhaul,</li> </ul> <p>Time-critical sensing and feedback for smart cities:<br/>30 ms end-to-end</p> | <p>For live streaming in crowded areas, services for media production, augmented reality for collaborative gaming etc.:<br/>20 ms end-to-end</p>   |

**Table 11: Standardized 5QI to QoS Characteristics mapping**

| 5QI Value                  | Resource Type   | Default Priority Level | Packet Delay Budget (NOTE 3)                           | Packet Error Rate                         | Default Maximum Data Burst Volume (NOTE 2) | Default Averaging Window |
|----------------------------|-----------------|------------------------|--|---|--|--------------------------|
| 1                          | GBR<br>(NOTE 1) | 20                     | 100 <del>ms</del><br>(NOTE 11,<br>NOTE 13)             | $10^{-2}$                                 | N/A  | 2000 <del>ms</del>       |
| 2                          |                 | 40                     | 150 <del>ms</del><br>(NOTE 11,<br>NOTE 13)             | $10^{-3}$                                 | N/A  | 2000 <del>ms</del>       |
| 3                          |                 | 30                     | 50 <del>ms</del><br>(NOTE 11,<br>NOTE 13)              | $10^{-3}$                                 | N/A  | 2000 <del>ms</del>       |
| 4                          |                 | 50                     | 300 <del>ms</del><br>(NOTE 11,<br>NOTE 13)             | $10^{-6}$                                 | N/A  | 2000 <del>ms</del>       |
| 65<br>(NOTE 9,<br>NOTE 12) |                 | 7                      | 75 <del>ms</del><br>(NOTE 7,<br>NOTE 8)                | $10^{-2}$                                 | N/A  | 2000 <del>ms</del>       |
| 66<br>(NOTE 12)            |                 | 20                     | 100 <del>ms</del><br>(NOTE 10,<br>NOTE 13)             | $10^{-2}$                                 | N/A  | 2000 <del>ms</del>       |
| 67<br>(NOTE 12)            |                 | 15                     | 100 <del>ms</del><br>(NOTE 10,<br>NOTE 13)             | $10^{-3}$                                 | N/A  | 2000 <del>ms</del>       |
| 75<br>(NOTE 14)            |                 |                        |  |   |  |                          |
| 71                         |                 | 56                     | 150 <del>ms</del><br>(NOTE 11,<br>NOTE 13,<br>NOTE 15) | $10^{-6}$                                 | N/A  | 2000 <del>ms</del>       |
| 72                         |                 | 56                     | 300 <del>ms</del><br>(NOTE 11,<br>NOTE 13,<br>NOTE 15) | $10^{-4}$                                 | N/A  | 2000 <del>ms</del>       |
| 73                         |                 | 56                     | 300 <del>ms</del><br>(NOTE 11,<br>NOTE 13,<br>NOTE 15) | $10^{-8}$                                 | N/A  | 2000 <del>ms</del>       |
| 74                         |                 | 56                     | 500 <del>ms</del><br>(NOTE 11,<br>NOTE 15)             | $10^{-8}$                                 | N/A  | 2000 <del>ms</del>       |
| 76                         |                 | 56                     | 500 <del>ms</del><br>(NOTE 11,<br>NOTE 13,<br>NOTE 15) | $10^{-4}$                                 | N/A  | 2000 <del>ms</del>       |
| 5                          |                 | Non-GBR                | 10   | 100 <del>ms</del><br>NOTE 10,<br>NOTE 13) | $10^{-6}$                                  | N/A                      |
| 6                          | (NOTE 1)        | 60                     | 300 <del>ms</del><br>(NOTE 10,<br>NOTE 13)             | $10^{-6}$                                 | N/A  | N/A                      |
| 7                          |                 | 70                     | 100 <del>ms</del><br>(NOTE 10,<br>NOTE 13)             | $10^{-3}$                                 | N/A  | N/A                      |



# Discrete automation – Motion Control

Industrial Factory Automation - Closed-Loop Control Applications.

e.g. Motion Control of Robots, Machine Tools, as well as Packaging and Printing Machines.

The pertinent standard suite is IEC 61158. Note that clock synchronization is an integral part of fieldbuses used for motion control.

In motion control applications, a controller interacts with a large number of sensors and actuators (e.g. up to 100), which are integrated in a manufacturing unit. The resulting sensor/actuator density is often very high (up to  $1 \text{ m}^{-3}$ ). Many such manufacturing units may have to be supported within close proximity within a factory (e.g. up to 100 in automobile assembly line production).

The Cycle Time can be as low as 2 ms, setting stringent E2E Latency constraints on telegram forwarding (1 ms).

The communication service has also to be highly available (99,9999%).

## Service area and connection density

Factory halls can be rather large and even quite high. We set the upper limit at 1000 x 1000 x 30 m.







# Summary of 3GPP SCEF Services

1. The APIs enable many use cases for applications by the Enterprise.
2. Device Trigger Delivery
3. Sponsored Data
4. UE Reachability and Monitoring
5. Inform 3<sup>rd</sup> Party of Network Issues and set QoS for the UE session
6. UE Footprint
7. 3<sup>rd</sup> Party Interaction for UE Patterns
8. Group Message Delivery
9. Background Data Transfer
10. Packet Flow Descriptor (PFD) Management
11. MSISDN-less MO-SMS
12. Enhanced Coverage Restriction Control
13. Network Configuration Parameters

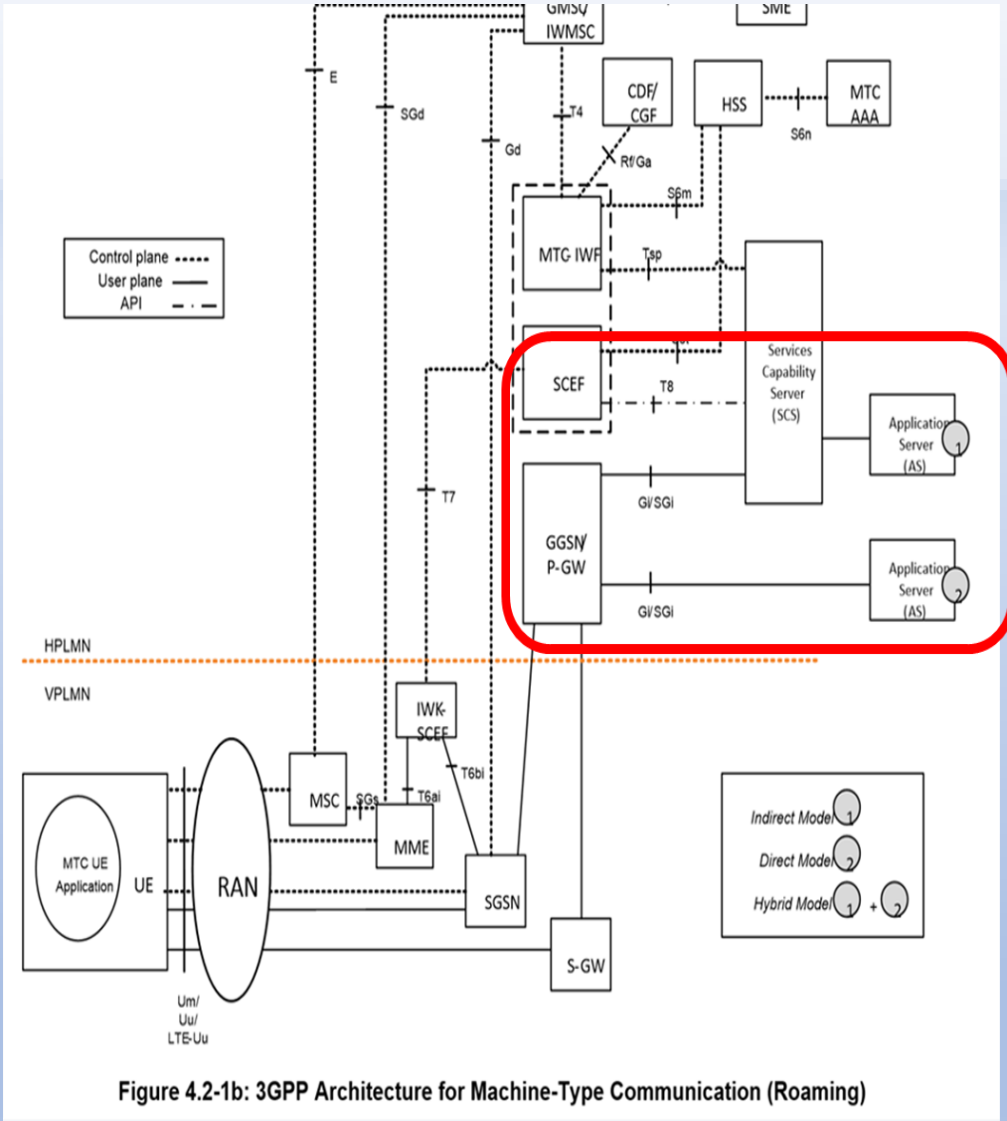
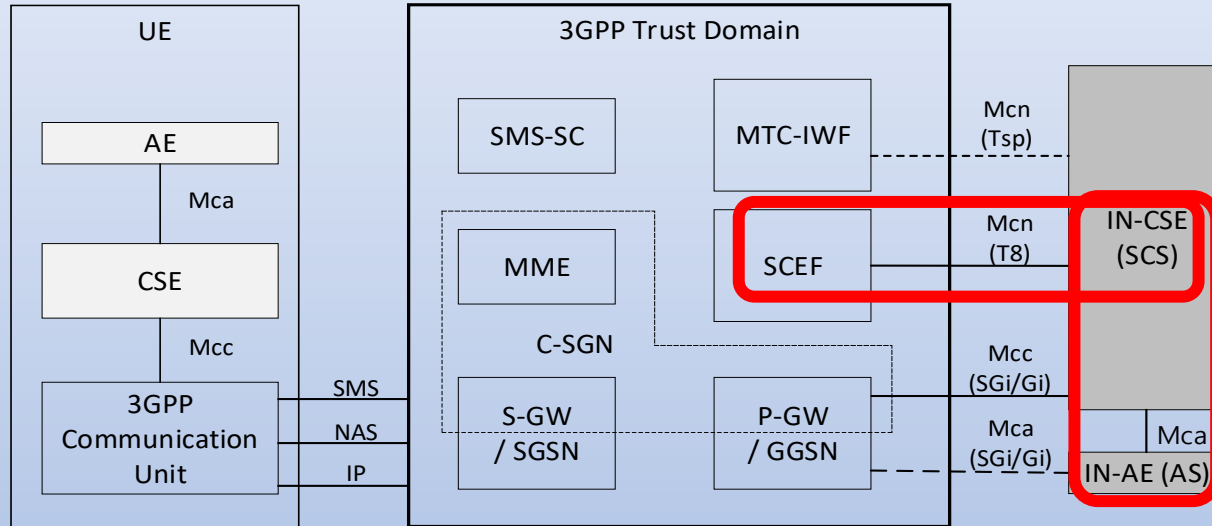

Figure 4.2-1b: 3GPP Architecture for Machine-Type Communication (Roaming)

# 3GPP 5G SCEF/SCS for IoT Platform integrated with IoT SL across 10 UCs - 1

## Functional mapping between 3GPP and oneM2M

Figure 5.2-1 shows an Architecture and Functional mapping for the 3GPP Trust Domain which describes how oneM2M Functional Entities may access Features and Services that are exposed by 3GPP.



Optionally present oneM2M entity     
  oneM2M entity  
 - - - - - Direct connection option not currently supported     
 - - - - - Tsp is not focus at this TS

**Figure 5.2-1: oneM2M Interfaces to the underlying 3GPP Network**

Several implementation options for the placement of the oneM2M IN-CSE relative to the SCEF and the underlying 3GPP network are envisioned. In all implementations, the SCEF always resides within 3GPP domain.

In some options the IN-CSE and the SCEF are deployed by a MNO and are both part of the operator domain. In other options the SCEF is part of the 3GPP domain and the IN-CSE is not part of the operator domain.

In all options, services within the IN-CSE may access the network services that are exposed by the SCEF via the T8 reference point APIs.

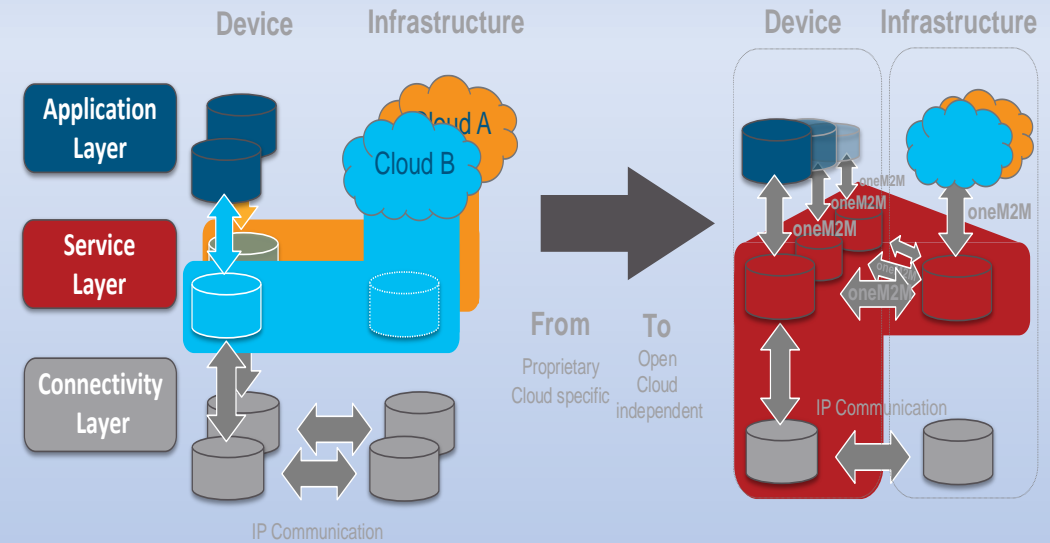

**Figure 5.1.1-3: Cloud provider independent**

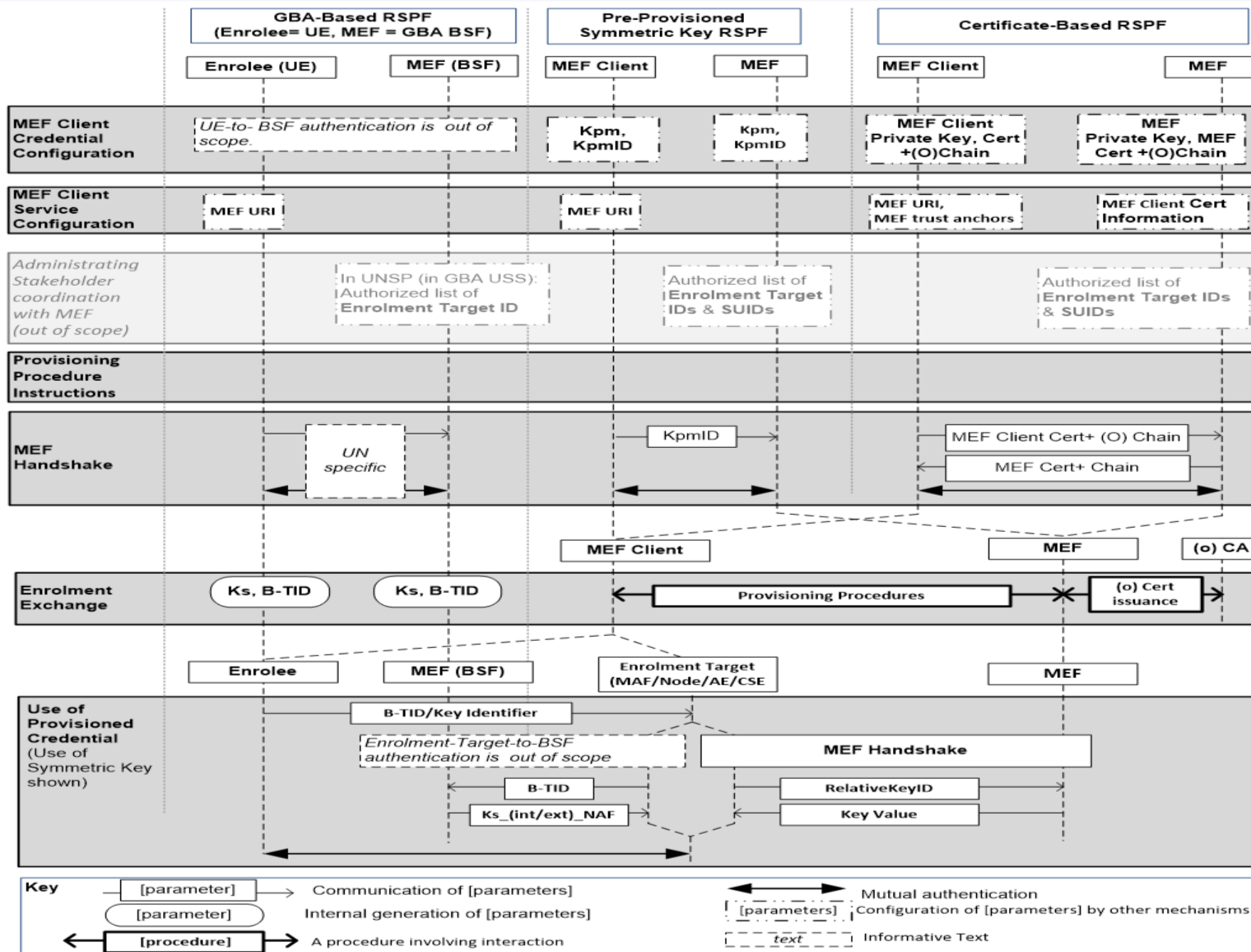

Figure 8.3.1.2-1: Overview of the Remote Security Provisioning Frameworks supported by oneM2M

# oneM2M Service Layer (SL) - Horizontal Architecture providing a Common Framework for IoT,

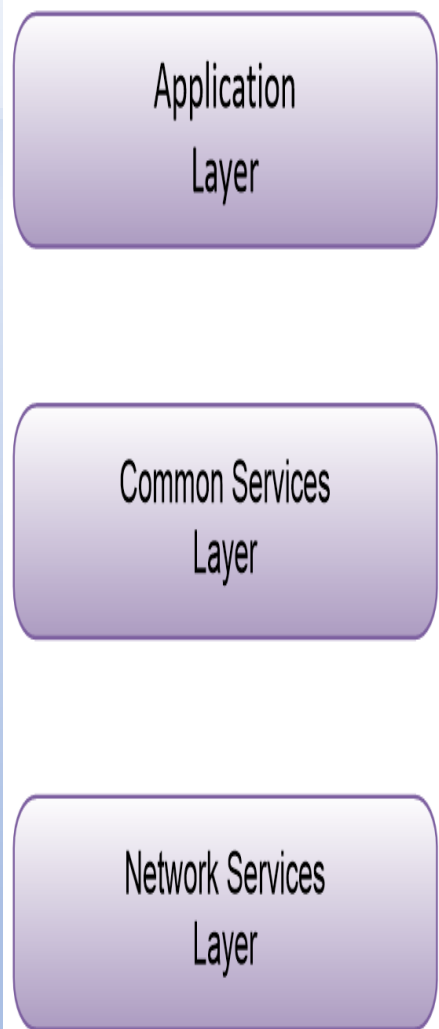

Fig 5.1-1: oneM2M Layered Model

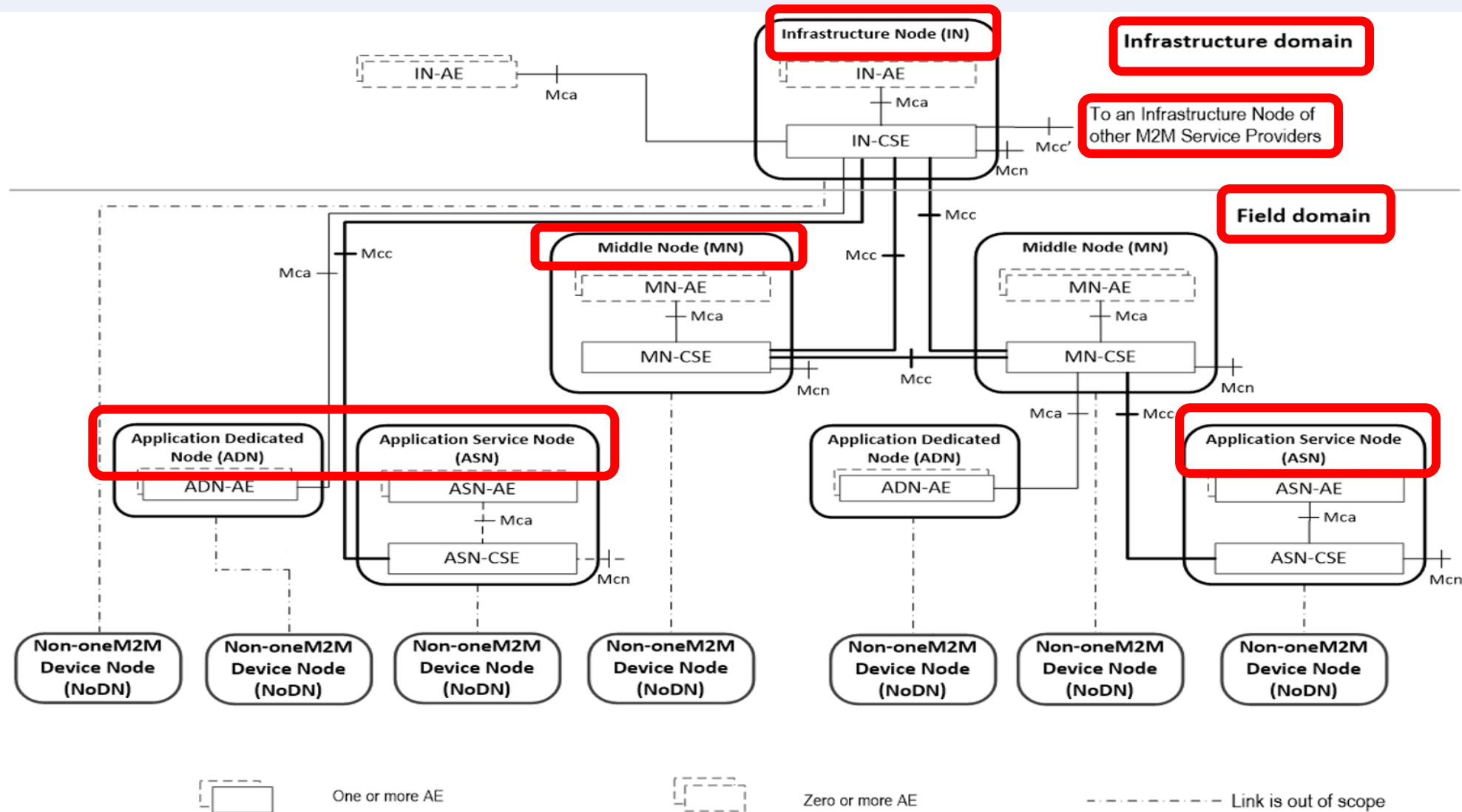

Figure 6.1-1: Configurations supported by oneM2M Architecture

## oneM2M Service Layer (SL) - Horizontal Architecture providing a Common Framework for IoT,

oneM2M has identified a **Set of Common Functionalities**, that are **applicable to all the IoT domains**.

Think of these **functions as a large toolbox with special tools to solve a number of IoT problems across many different domains**. The oneM2M CSFs are applicable to different IoT UCs in different industry domains.

oneM2M has standardized how these Functions are being executed, i.e. is has defined Uniform APIs to access these Functions.

Figure 6.2.0-1 shows a grouping of these Functions into a few different scopes.

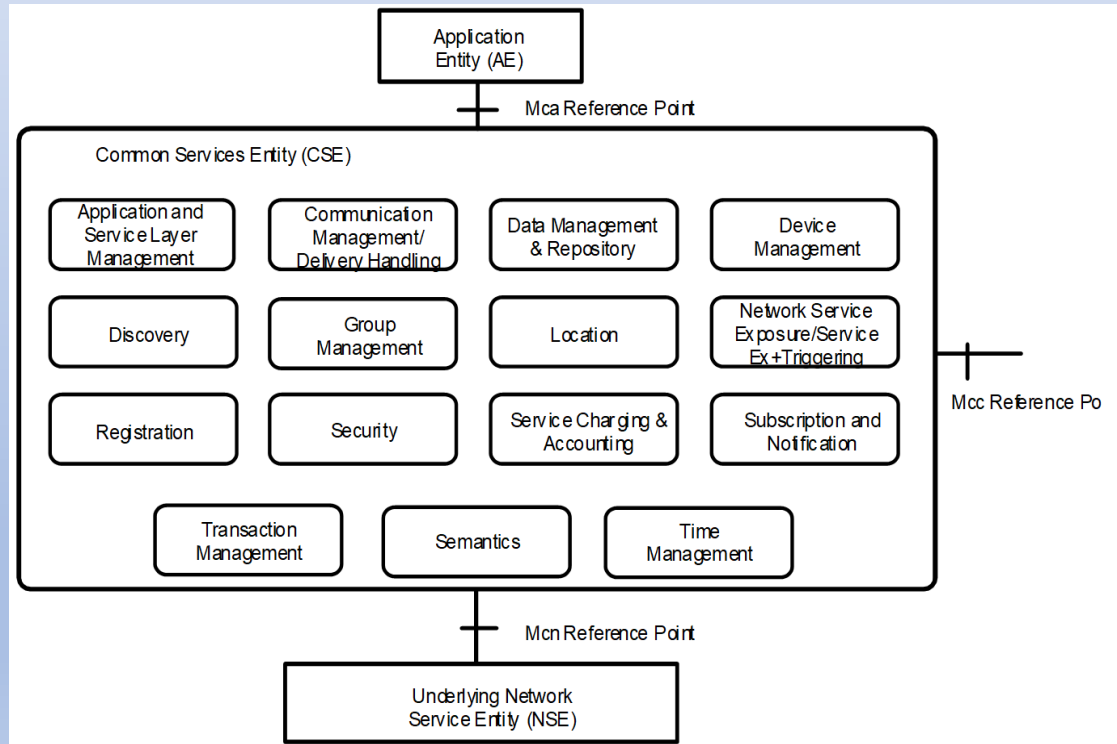

Fig. 6.2.0-1: Common Service Functions

## SAREF - Smart Applications REference Ontology

SAREF is the Reference Ontology for Smart Applications and contains recurring concepts that are used in several Domains. SAREF has a close relation with the oneM2M Base Ontology, for which a mapping is defined in clause 5.

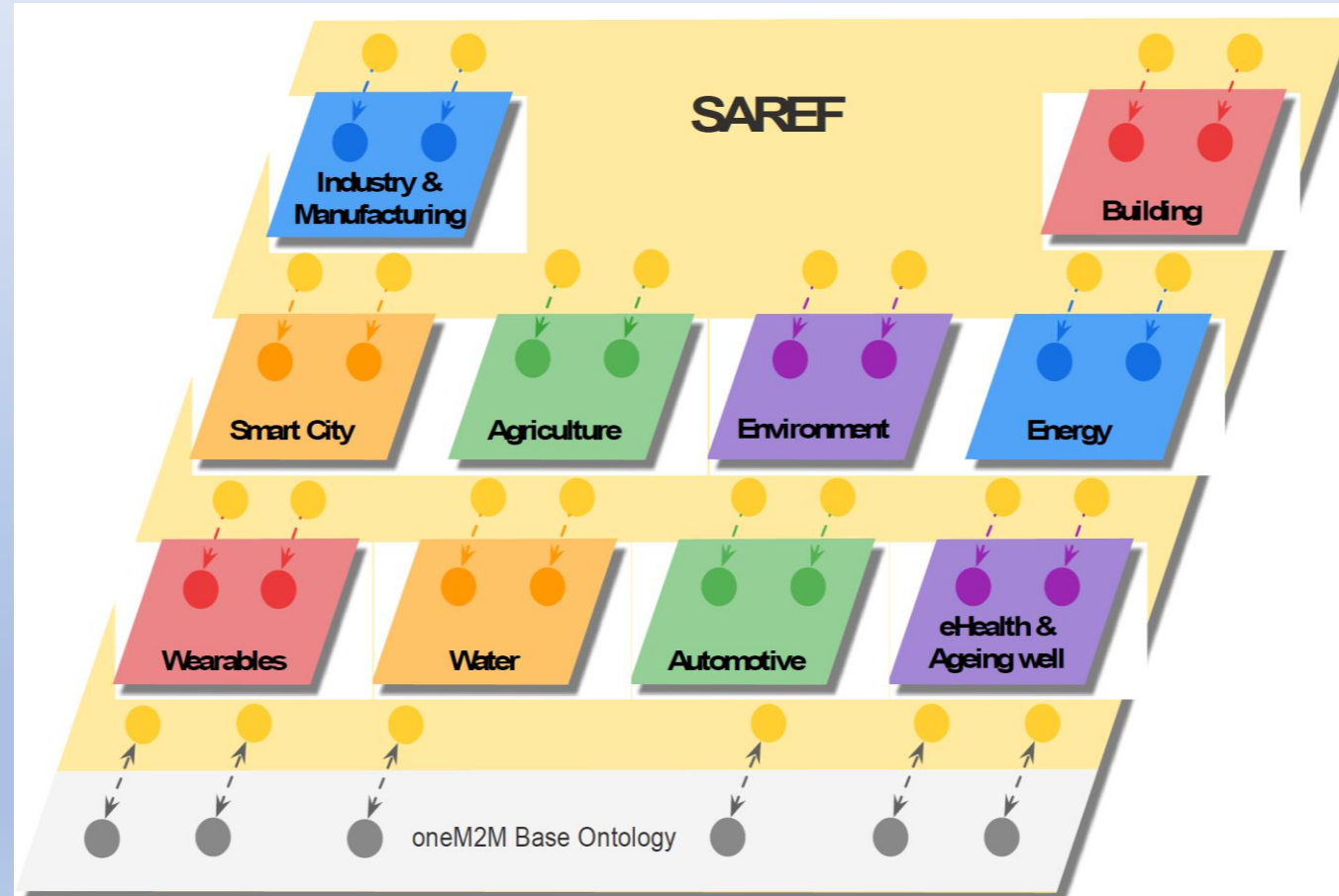

Figure 11: SAREF and its extensions



# oneM2M IoT SL Platform Layered Model and Cloud provider Independent

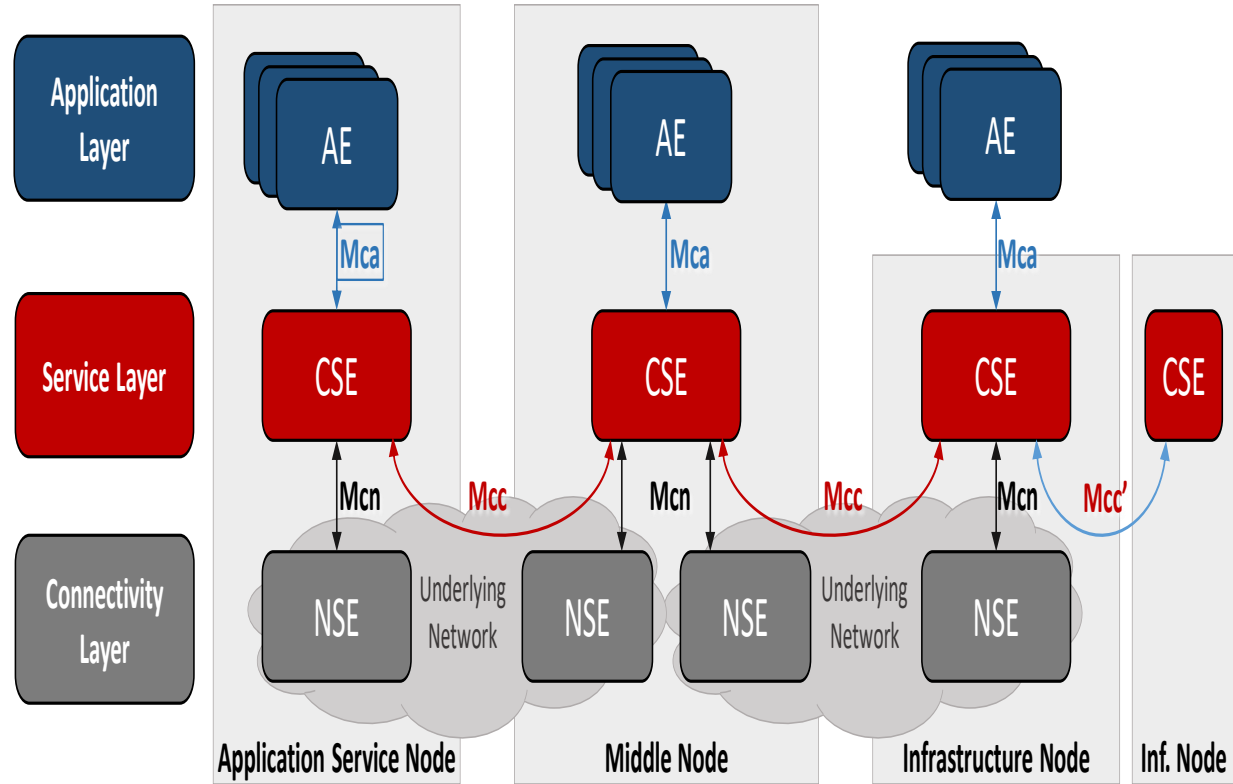

Figure 5.1.2-1: oneM2M Layered Model

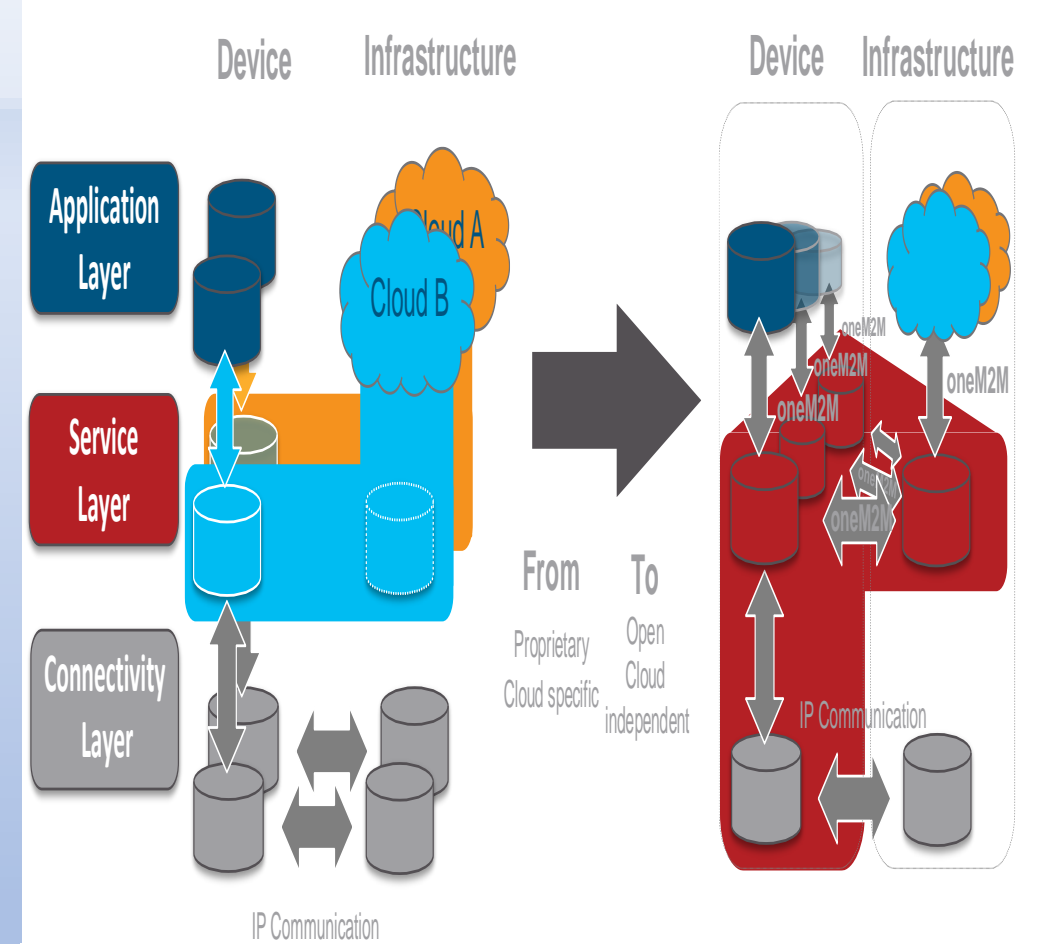

Figure 5.1.1-3: Cloud provider independent

# oneM2M Service Layer (SL) - Horizontal Architecture providing a Common Framework for IoT,



Fig 5.1-1: oneM2M Layered Model

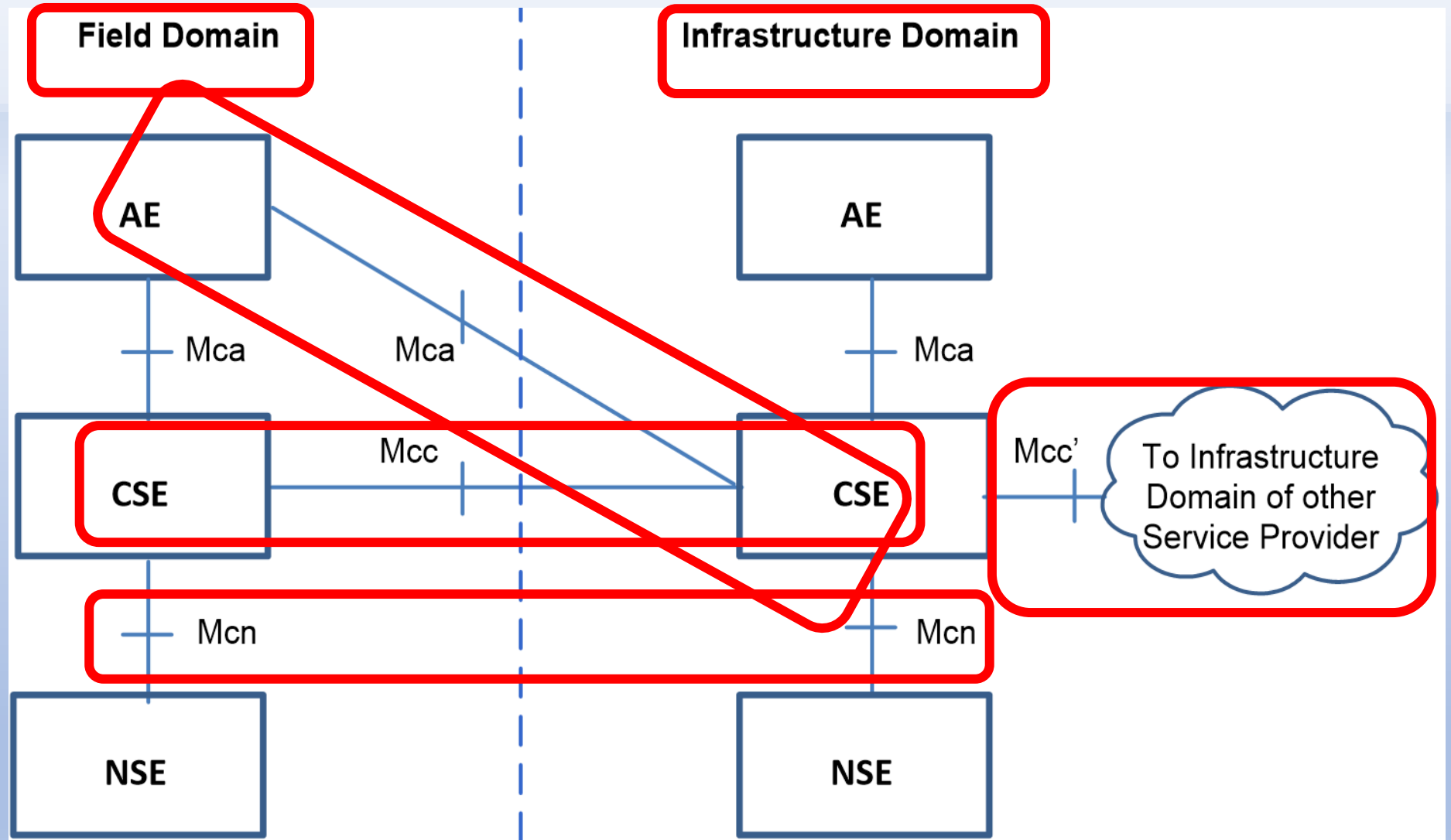

Figure 5.2.1-1: oneM2M Functional Architecture

# oneM2M Functional Architecture



## 6.2 Common Services Functions

This clause describes the services provided by the Common Services Layer in the M2M System. Such services reside within a CSE and are referred to as Common Services Functions (CSFs). The CSFs provide services to the AEs via the Mca reference point and to other CSEs via the Mcc reference point. CSEs interact with the NSE via the Mcn reference point. An instantiation of a CSE in a Node comprises a subset of the CSFs from the CSFs described in the present document.

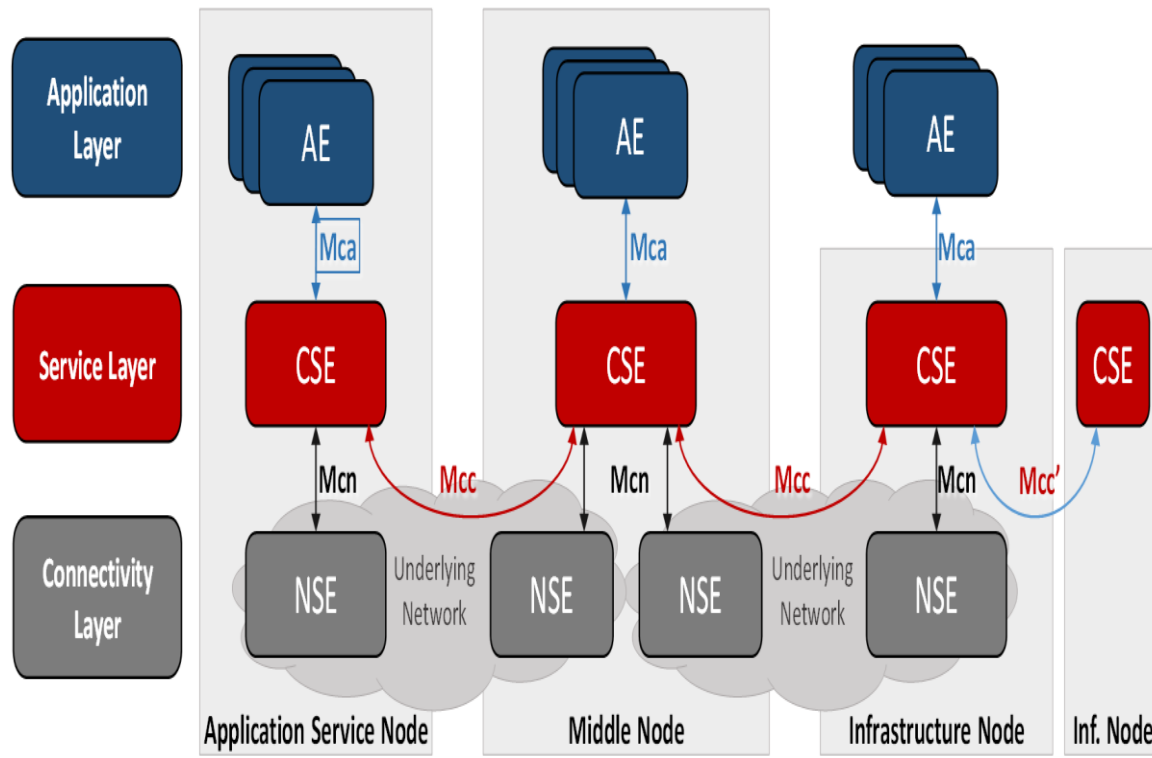
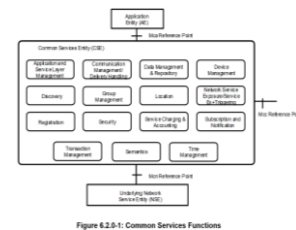

Figure 5.1.2-1: oneM2M Layered Model

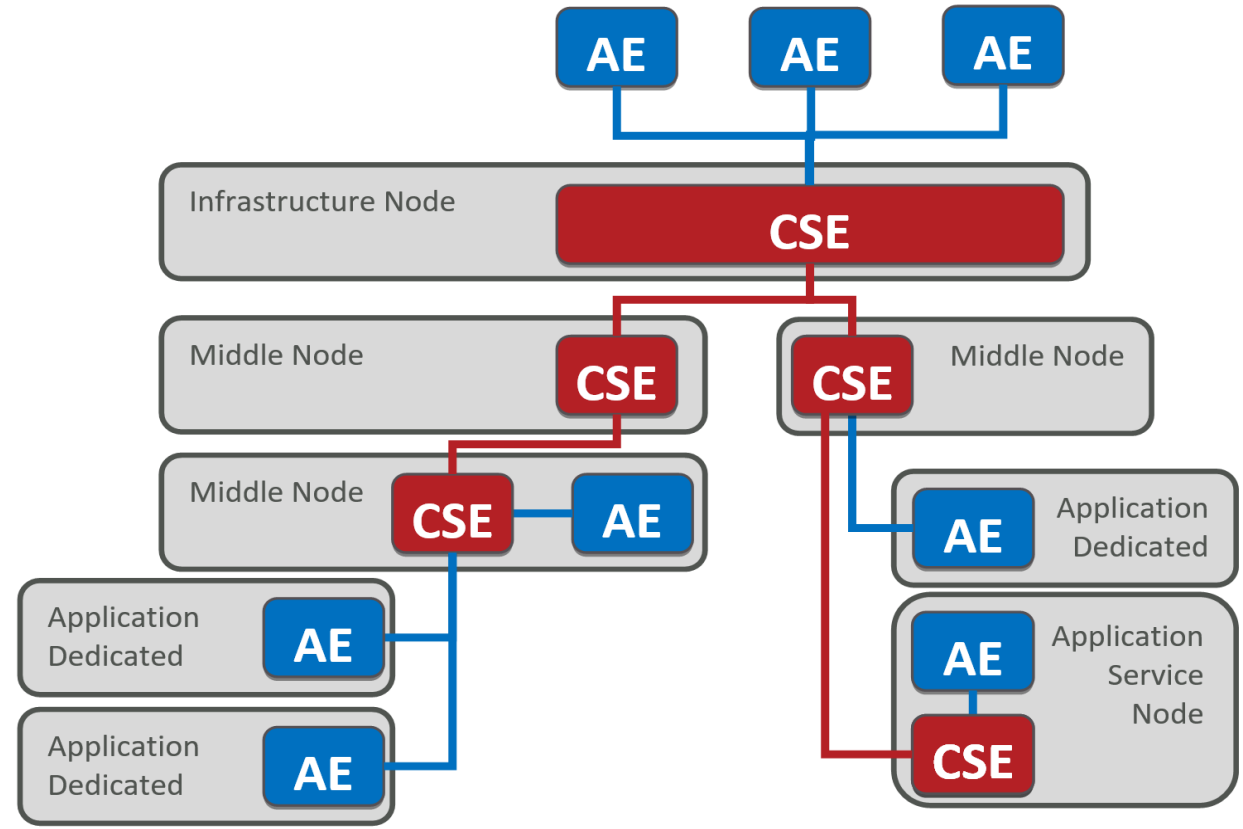

Figure 5.1.2-3: oneM2M node topology

# Semantic discovery in presence of a "Network" of M2M Service Providers (M2MSPs)

The oneM2M system should integrate already Standardized Ontology extensions to the current oneM2M Ontology to cope with new specific domains:

SAREF Core and its extensions:

- SAREF4BLDG,
- SAREF4ENVI,
- SAREF4ENERGY,
- SAREF4CITY,
- SAREF4AGRI,
- SAREF4WATER....

2) Based on Semantic information, the oneM2M System shall take routing decisions for forwarding a received ASDQ (Advanced Semantic Discovery Query).

The Semantic information will allow the oneM2M system to maximize and to accelerate the Semantic Discovery Process.

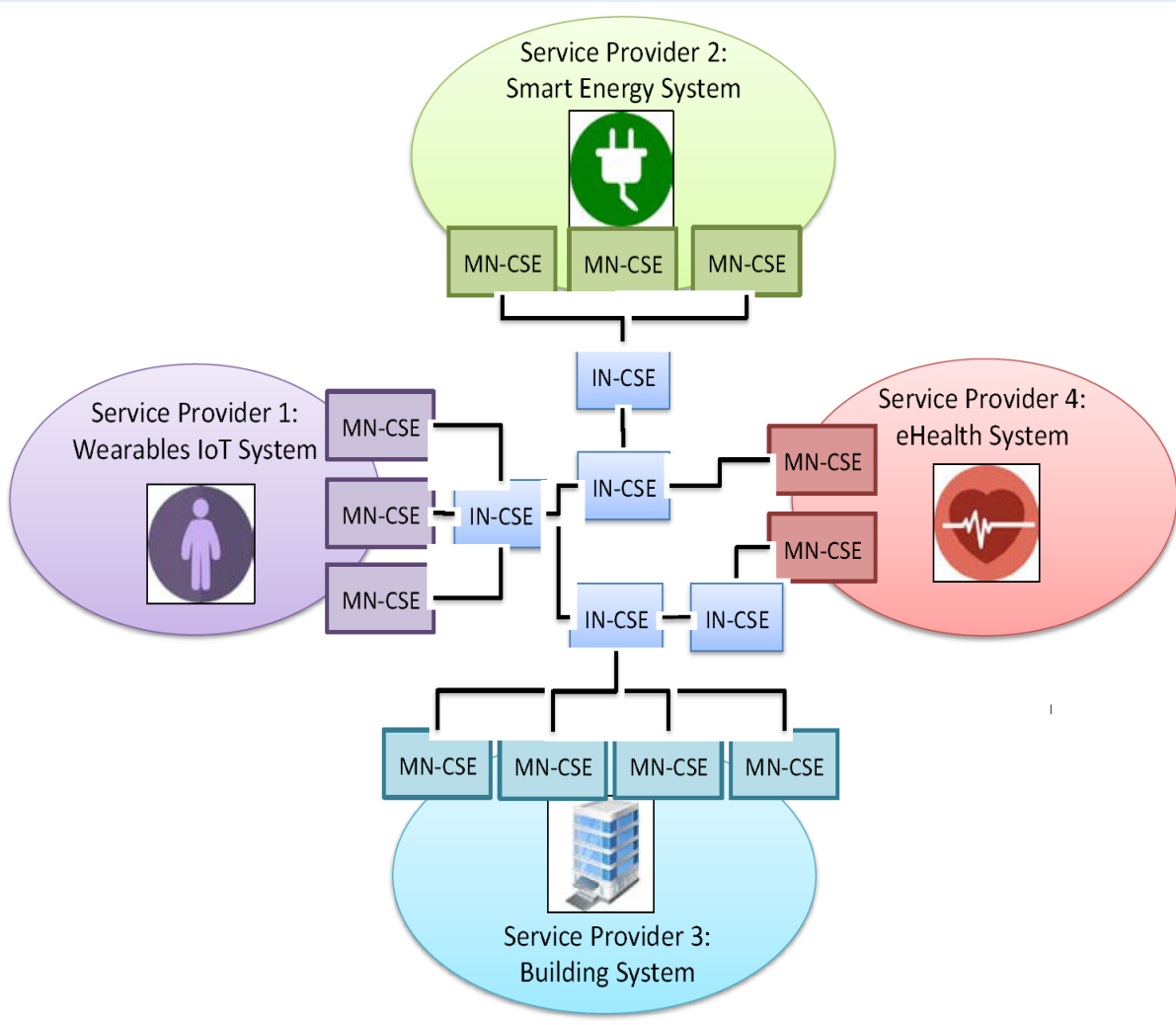

Figure 6.9-1: Semantic Recommendation in CSEs for Discovery

# Semantic discovery in presence of a "network" of M2M Service Providers (M2MSPs)

Ontologies and their OWL representations are used in oneM2M to provide syntactic and semantic interoperability of the oneM2M System with External Systems.

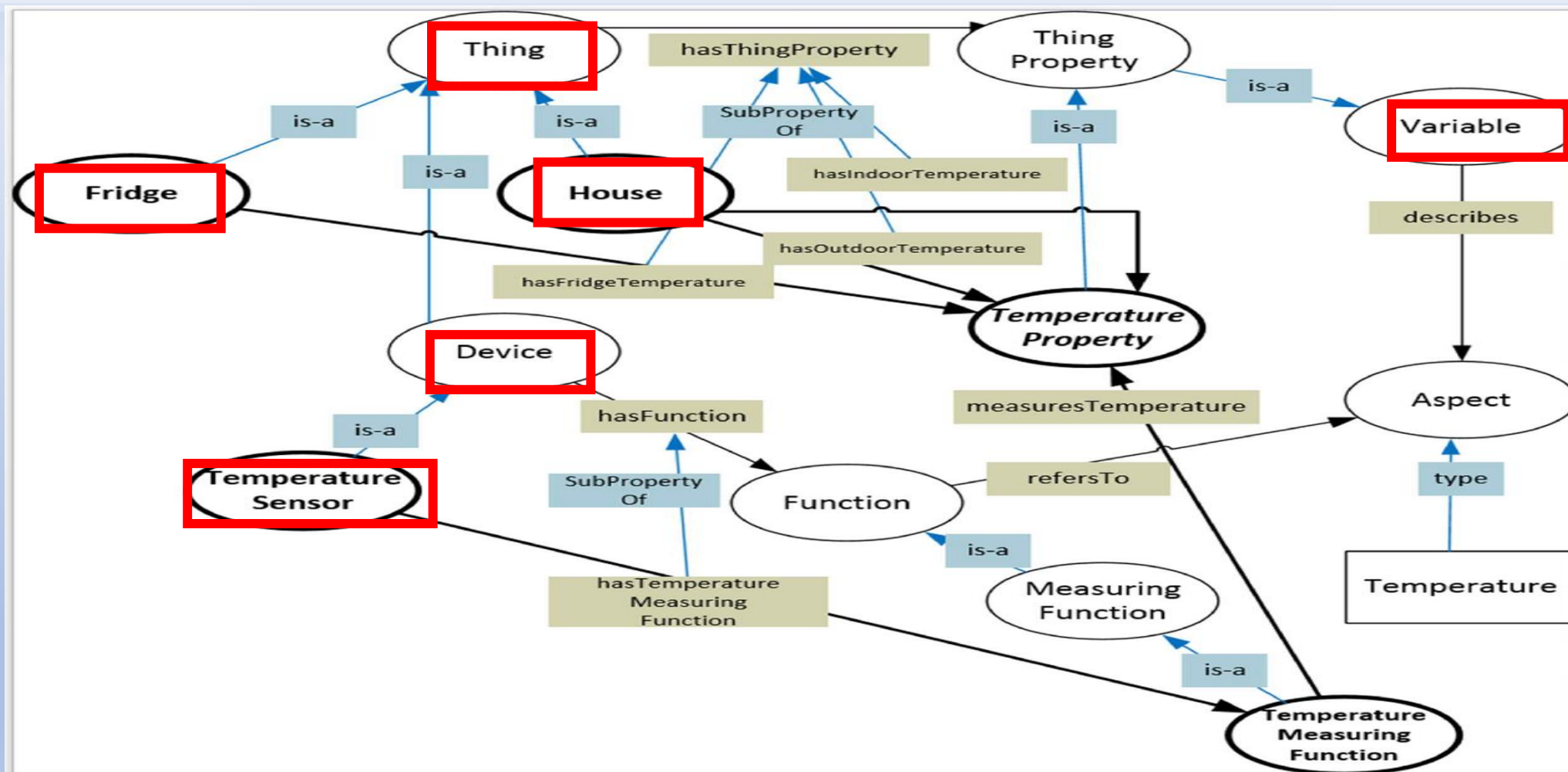
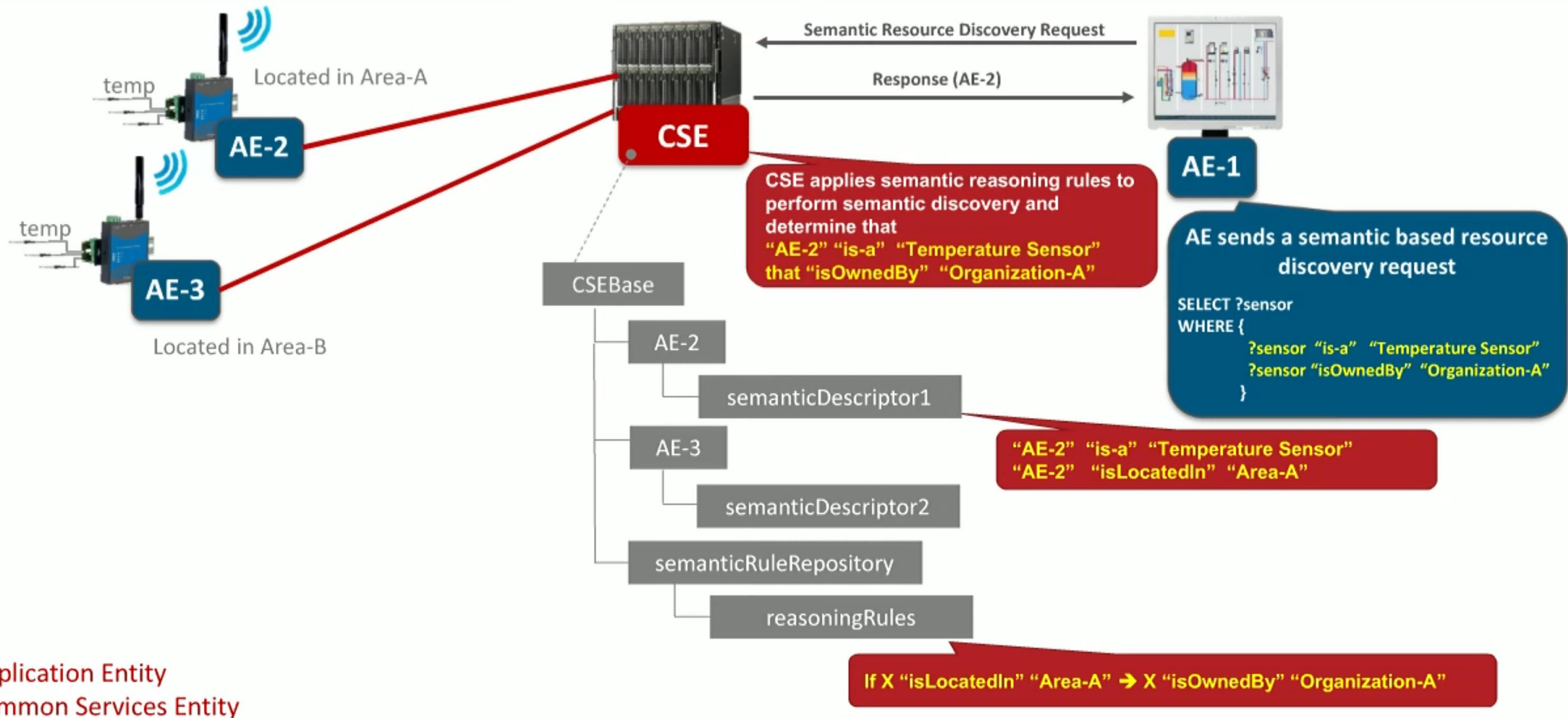

Figure 5.4.1-1: Example of mapping on the oneM2M Base Ontology

# Semantic Reasoning



AE: Application Entity  
CSE: Common Services Entity



# oneM2M Semantics Support

## 6 Description of Classes and Properties

### 6.1 Classes

#### 6.1.1 Class: Thing

### Class: Thing

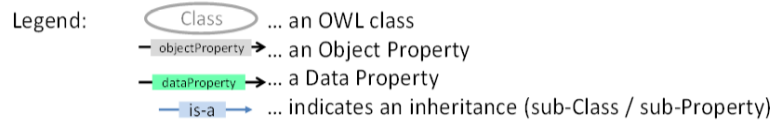
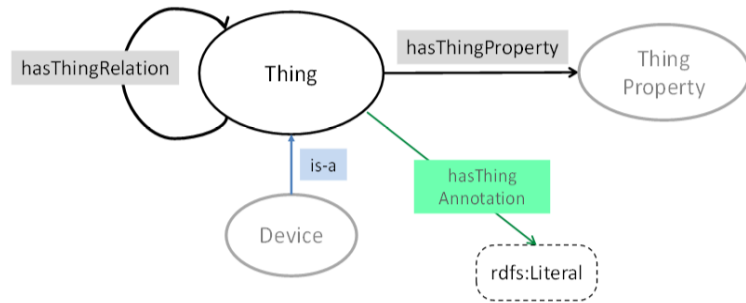

Figure 2: Thing

#### Description

- A **Thing** in oneM2M (Class: Thing) is an entity that can be identified in the oneM2M System. A Thing that is not a Device is not able to communicate electronically with its environment. However, the sub-class of Thing that *is* able to interact electronically is called a "Device". A Thing may have ThingProperties (Object Property: hasThingProperty). A Thing can have relations to other things (Object Property: hasThingRelation). Since a Thing that is not a Device is not able to communicate electronically it cannot influence the value of its ThingProperties or being influenced by it. Similarly a Thing cannot document its - real-world - relationships (via hasThingRelation) to other Things.

#### 6.1.2 Class: ThingProperty

### Class: ThingProperty

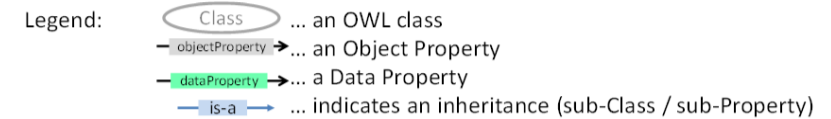
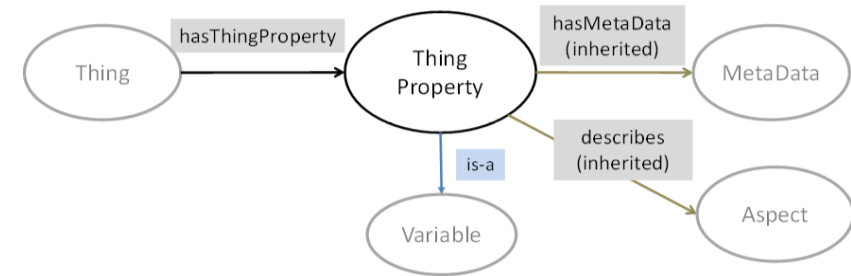

Figure 3: ThingProperty

#### Description

- A **ThingProperty** (Class: ThingProperty) denotes a property of a Thing. A ThingProperty can e.g. be observed or influenced by devices, or it constitutes static data about a Thing. E.g. the indoor temperature of the room could be a ThingProperty of a Thing "room". A ThingProperty of a thing can describe a certain Aspect, e.g. the indoor temperature describes the Aspect "Temperature" that could be measured by a temperature sensor. A ThingProperty of a Thing can have meta data.
- The class ThingProperty is a sub-class of the Variable class.

#### Object Properties

This Class is the domain Class of Object Property:

- describes (range Class: Aspect) (inherited from class: Variable)

# oneM2M Semantics Support

## 6.1.3 Class: Aspect

### Class: Aspect

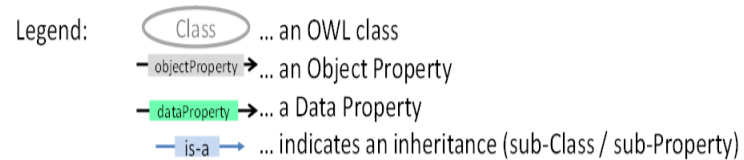
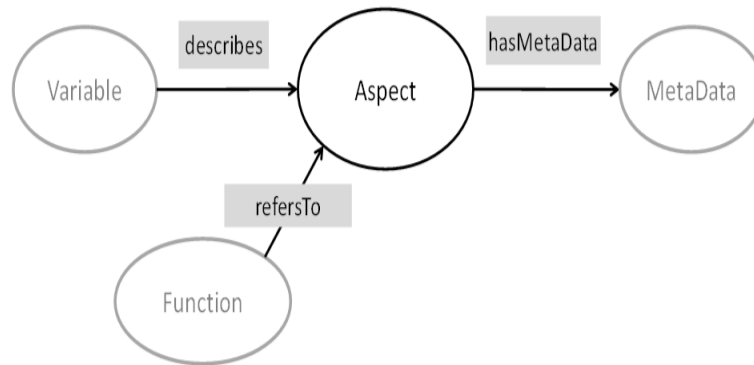

Figure 4: Aspect

#### Description

- An **Aspect** (Class: Aspect) describes the real-world aspect that a Function relates to. Aspect is also used to describe the quality or kind of a Variable. The Aspect could be a (physical or non-physical) entity or it could be a quality.

## 6.1.4 Class: MetaData

### Class: MetaData

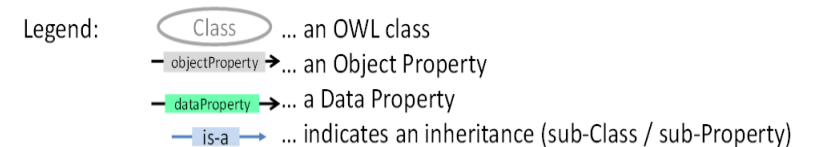
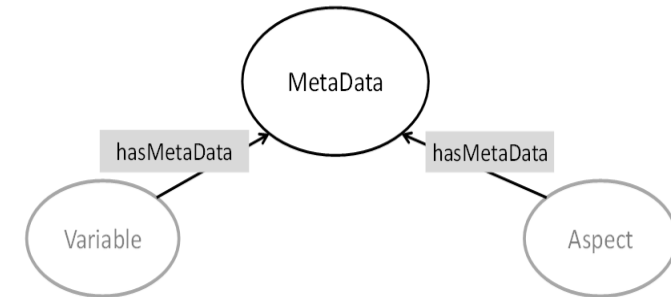

Figure 5: MetaData

#### Description

- MetaData** (Class: MetaData) contain data (like units, precision-ranges ...) about a Variable or about an Aspect. E.g. the indoor temperature could have as meta data an individual "Celsius\_Scale" that specifies that the temperature needs to be understood as degrees Celsius.

#### Object Properties

# oneM2M Semantics Support

## 6.1.5 Class: Device

### Class: Device

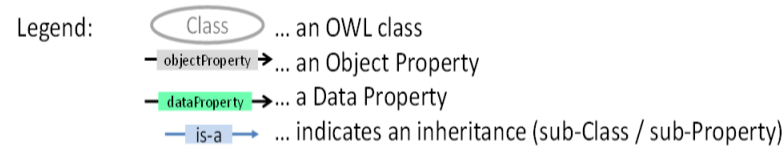
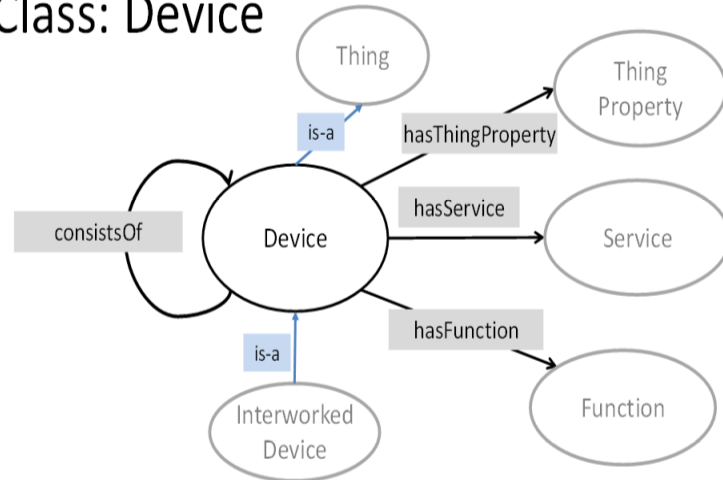

Figure 6: Device

### Description

- A **Device** (Class: Device) is a Thing (a sub-class of class:Thing) that is designed to accomplish a particular task via the Functions the Device performs. A Device can be able to interact electronically with its environment via a network. A Device contains some logic and is producer and/or consumer of data that are exchanged via its Services with other oneM2M entities (Devices, Things) in the network. A Device may be a physical or non-physical entity. A Device interacts through the DataPoints and/or Operations of its Services:

## 6.1.6 Class: InterworkedDevice

### Class: InterworkedDevice

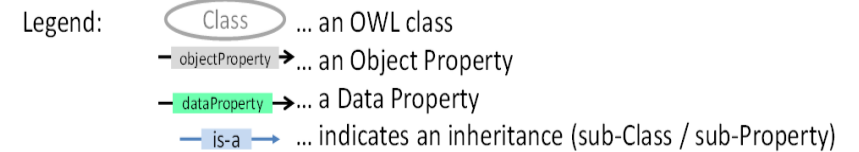
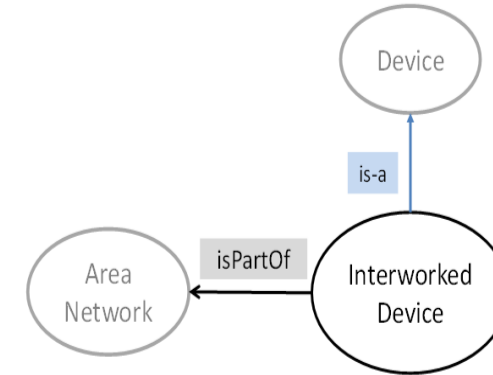

Figure 7: InterworkedDevice

### Description

- An **InterworkedDevice** (Class: InterworkedDevice) is a Device - e.g. in an Area Network - that does not support oneM2M interfaces and can only be accessed from the oneM2M System by communicating with a "proxied" (virtual) device that has been created by an Interworking Proxy Entity.

# oneM2M Semantics Support

## 6.1.7 Class: AreaNetwork

### Class: AreaNetwork

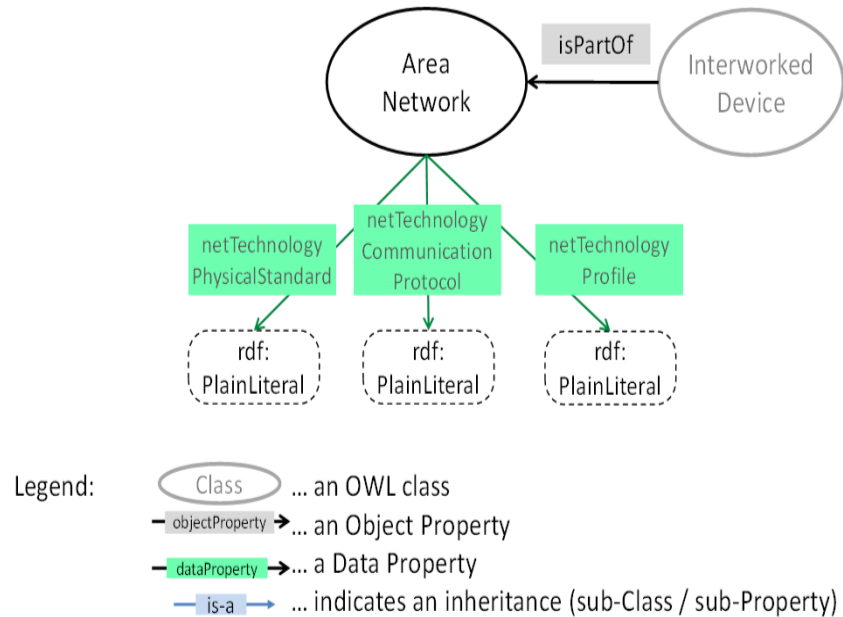

Figure 8: AreaNetwork

#### Description

- An **AreaNetwork** (Class: AreaNetwork) is a Network that provides data transport services between an Interworked Device and the oneM2M System. Different area Networks can use heterogeneous network technologies that may or may not support IP access.

## 6.1.8 Class: Service

### Class: Service

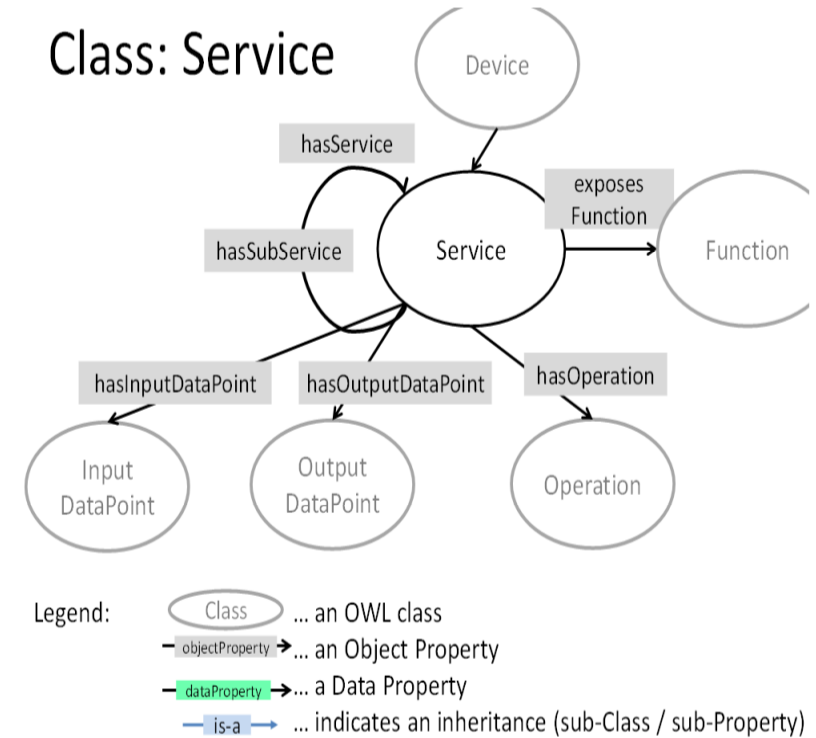

Figure 9: Service

#### Description

- A **Service** (Class: Service) is an electronic representation of a Function in a network. The Service exposes the Function to the network and makes it discoverable, registerable and remotely controllable in the network. A Service is offered by a device that wants (a certain set of) its Functions to be discoverable, registerable, remotely controllable by other devices in the network. A Service can expose one or more Functions and a Function can be exposed by one or more Services.

# oneM2M Semantics Support

## 6.1.9 Class: Function

### 6.1.9.0 General description

Classes: Function,  
Controlling-, Measuring-

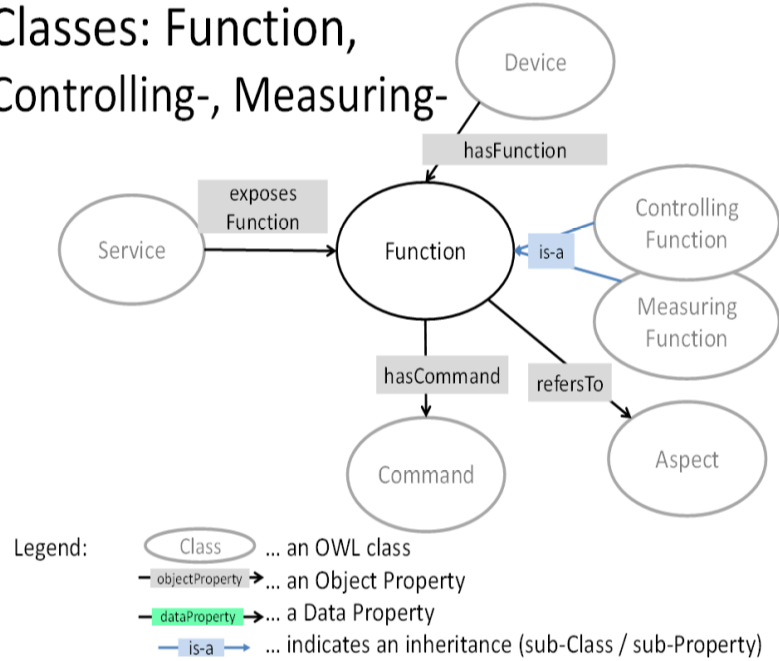

Figure 10: Function

### Description

- A **Function** (Class: Function) represents a particular function necessary to accomplish the task for which a Device is designed. A device can be designed to perform more than one Function. The Function exhibits the - human understandable - meaning what the device "does".
- A Function refers to (e.g. observes or influences) some real-world aspect(s), that can be modelled as a Class: Aspect.

## 6.1.10 Class: Operation

### 6.1.10.0 General description

Class: Operation

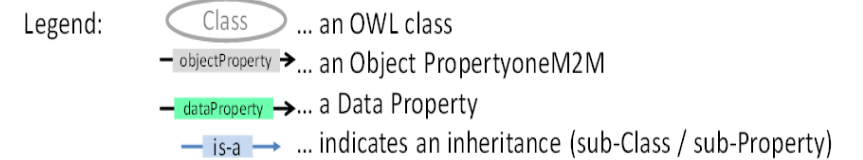
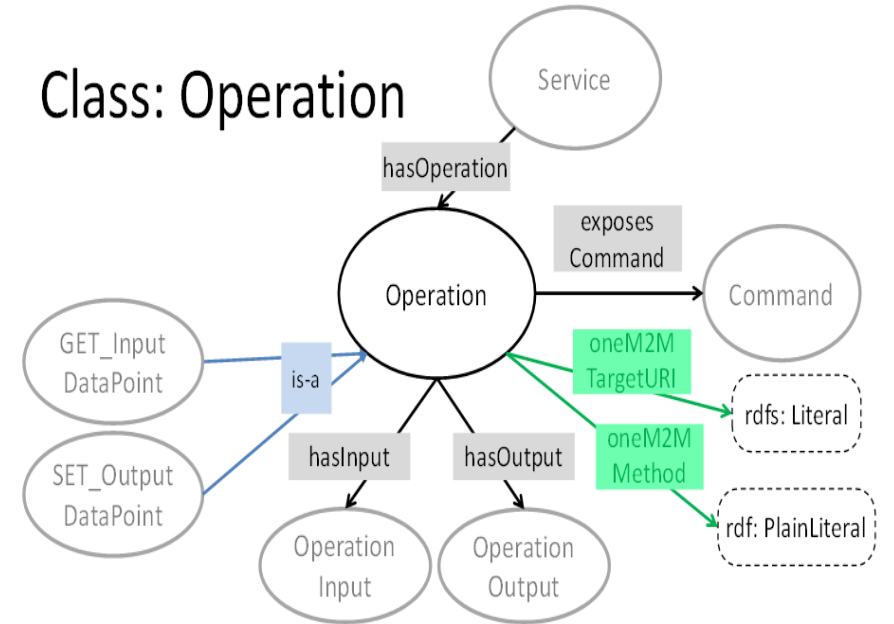
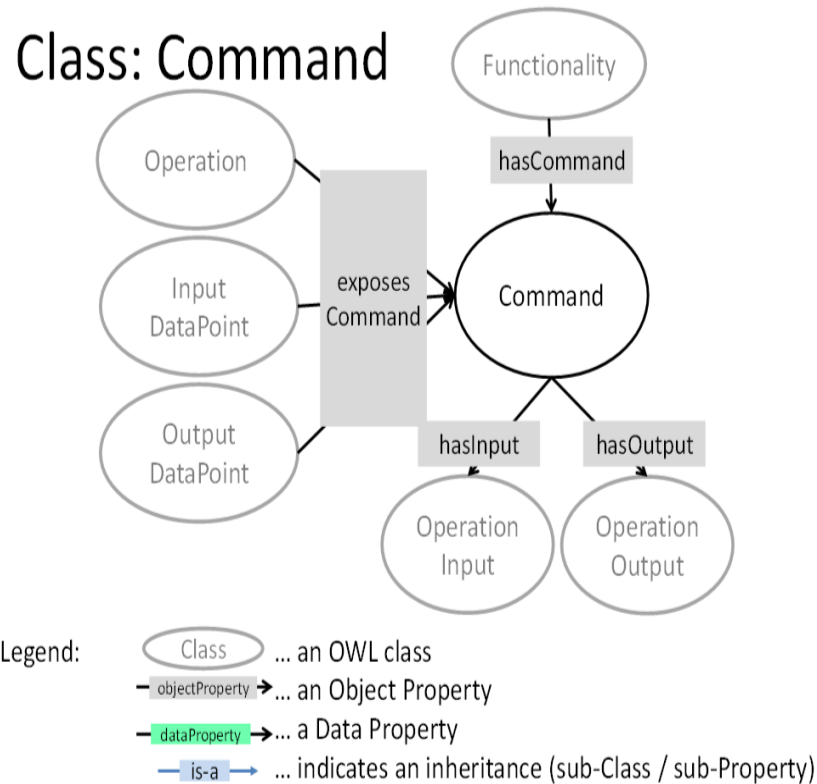

Figure 11: Operation



# oneM2M Semantics Support

## 6.1.11 Class: Command



**Figure 12: Command**

### Description

- A **Command** (Class: Command) represents an action that can be performed to support the Function. A Command is the -human understandable - name of that action that is invoked in a device or is reported by the

## 6.1.12 Class: OperationInput

### Class: OperationInput

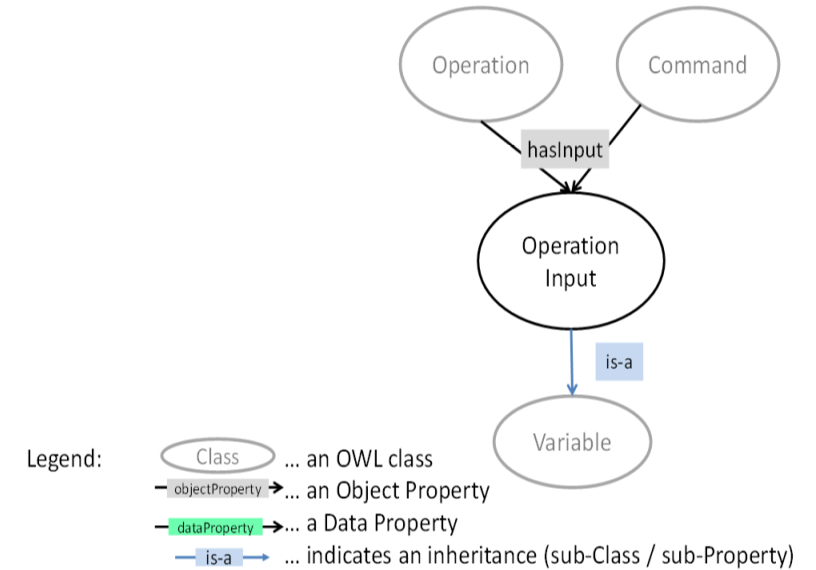

**Figure 13: OperationInput**

### Description

- OperationInput** (Class: OperationInput) describes an input of an Operation of a Service. OperationInput also describes the input of a Command:
  - OperationInput is transient. An instance of OperationInput is deleted when the instance of its Operation is deleted.
  - An Operation/Command may have multiple OperationInputs and/or OperationOutputs. If an instance of an Operation is invoked then the input value to that Operation shall be an instance of its OperationInput class.

# oneM2M Semantics Support

## 6.1.16 Class: Variable

### 6.1.16.0 General description

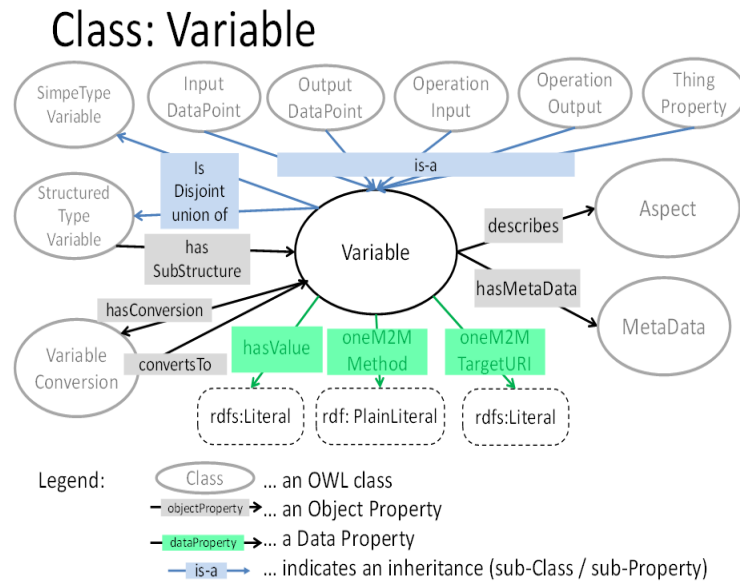

Figure 17: Variable

#### Description

- A **Variable** (Class: Variable) constitutes a super class to the following classes: ThingProperty, OperationInput, OperationOutput, InputDataPoint, OutputDataPoint. Additionally, class:Variable is the disjoint union of classes: SimpleTypeVariable and StructuredTypeVariable, i.e. any member of class:Variable is also member of either SimpleTypeVariable or StructuredTypeVariable. The members of class:Variable are entities that store some data (e.g. integers, text, etc., or structured data) that can change over time. These data of the Variable usually describe some real-world Aspects (e.g. a temperature) and can have MetaData (e.g. units, precision, etc.).

## 6.1.16.2 Class: StructuredTypeVariable

### Class: StructuredTypeVariable

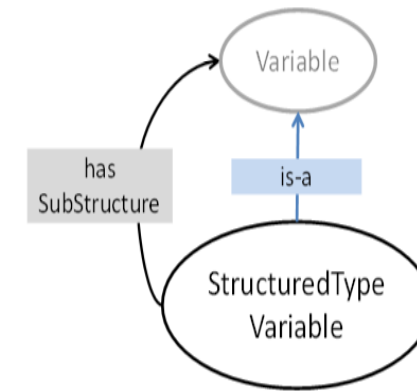

#### Legend:

- Class ... an OWL class
- objectProperty → ... an Object Property
- dataProperty → ... a Data Property
- is-a → ... indicates an inheritance (sub-Class / sub-Property)

Figure 19: Variable

# ETSI SmartM2M Semantic discovery in presence of a "Network" of M2M Service Providers (M2MSPs)

## Advanced Semantic Discovery (ASD)

Figure 6.3.2-1 describes oneM2M as-is Semantic Discovery involving multiple CSEs.

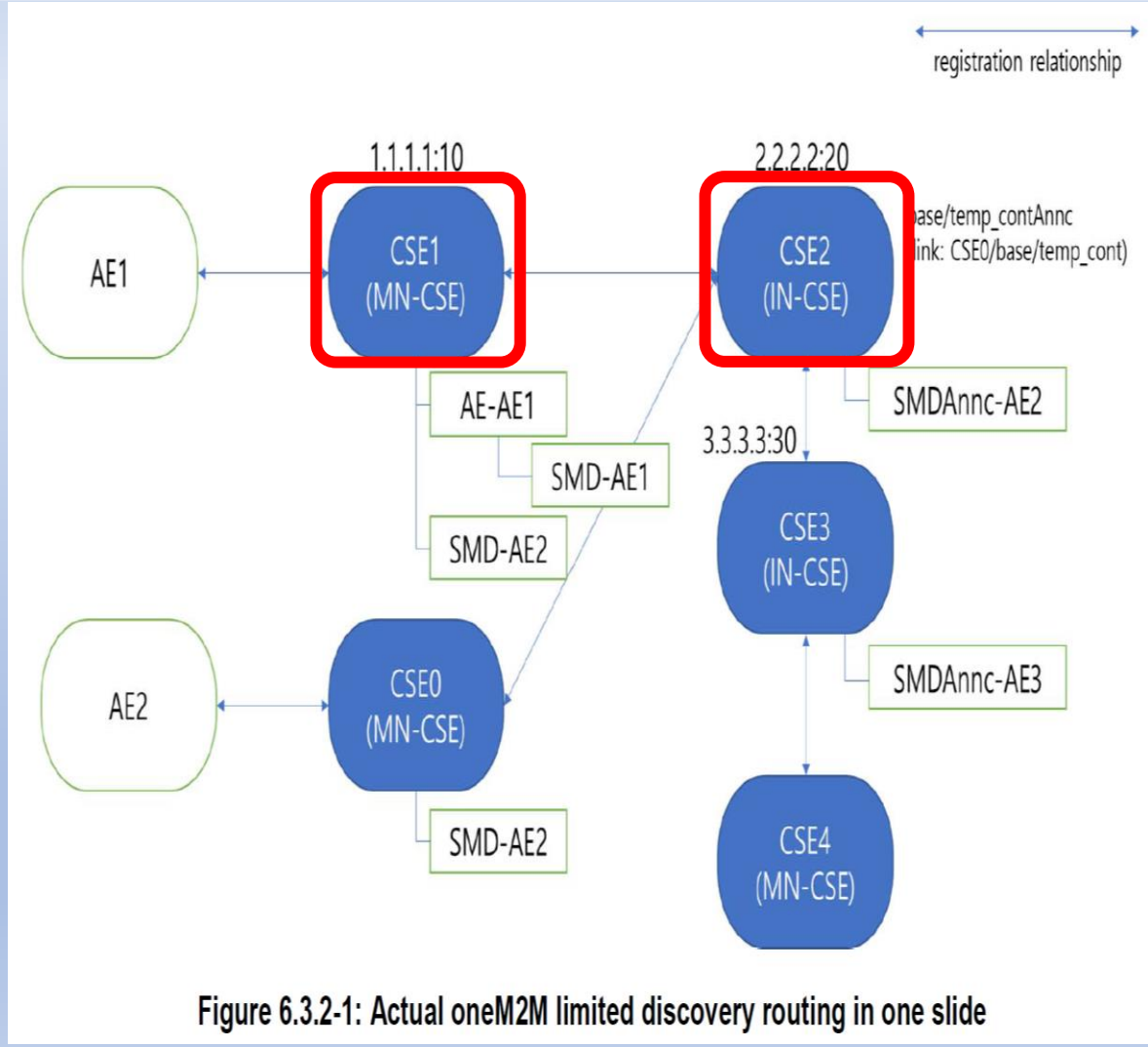

Figure 6.3.2-1: Actual oneM2M limited discovery routing in one slide

# Advanced Semantic Discovery (ASD) - 1

## Semantic Discovery in presence of a "Network" of M2M Service Providers (M2MSPs)

The Advanced Semantic Discovery aims to discover AEs (also called Resources) that are registered/announced to some CSEs.

The ASD could start from any AE, even these ones not belonging to the same Trusted Domain.

The ASD differs from the usual one present in oneM2M in the sense that one (or many) AE could be searched for even without knowing its identifier, but just knowing its TYPE or ONTOLOGY membership, as shown in Figure 6.3.1-1.

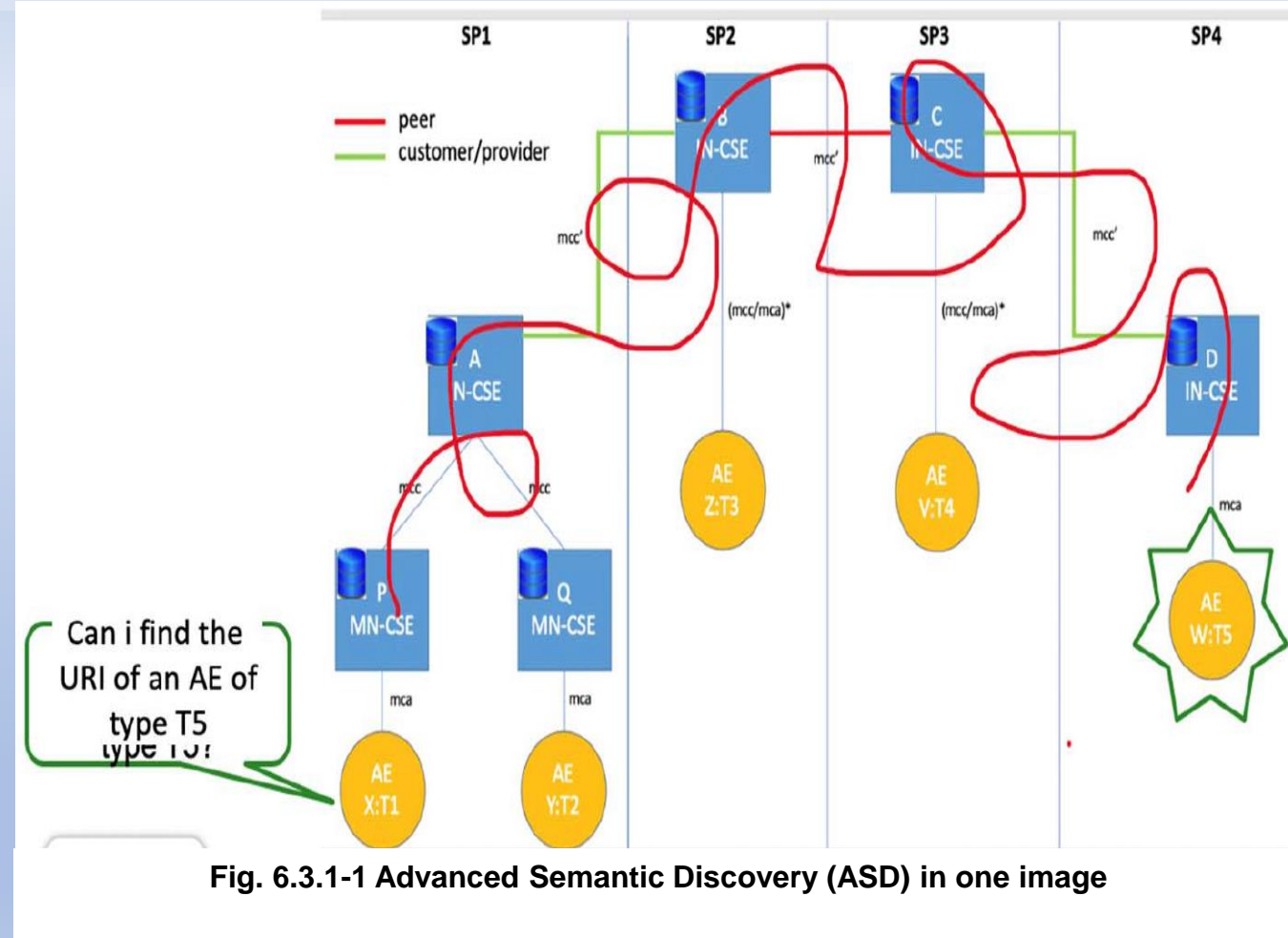

Fig. 6.3.1-1 Advanced Semantic Discovery (ASD) in one image



# Semantic discovery in presence of a "Network" of M2M Service Providers (M2MSPs)

ASD within Distributed Network of CSEs belonging a single Service Provider & across different IoT Service Providers.

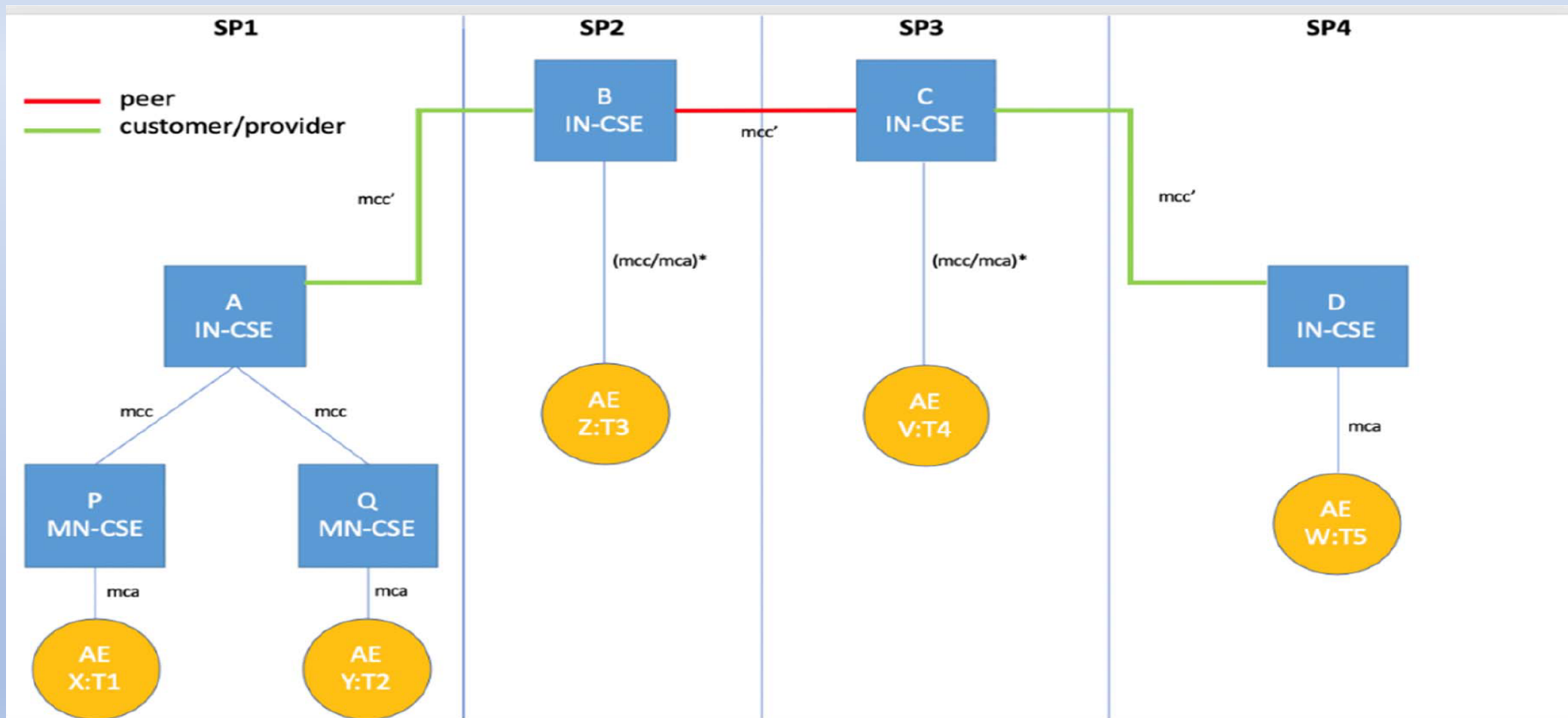

Figure 5.4-1: Pre-condition topology



## 5 Use Case - Semantic discovery in presence of a "network" of M2M SP

Table 7.2.7-1: SRT with Recommendation System

| TYPE                  | BUCKETS[TYPE]   | CSE CUSTOMERS  | CSE PEERS      | CSE PROVIDERS  |
|-----------------------|-----------------|----------------|----------------|----------------|
| THERMOMETER           | CSE_1 ... CSE_q | (CSE_1, #cu_1) | (CSE_1, #pe_1) | (CSE_1, #pr_1) |
|                       |                 | ...            | ...            | ...            |
| WATER_VALVE           | CSE_1 ... CSE_r | (CSE_x, #cu_m) | (CSE_y, #pe_m) | (CSE_z, #pr_m) |
|                       |                 | ...            | ...            | ...            |
| AIR_POLLUTION_STATION | CSE_1 ... CSE_s | (CSE_1, #cu_1) | (CSE_1, #pe_1) | (CSE_1, #pr_1) |
|                       |                 | ...            | ...            | ...            |
|                       |                 | (CSE_x, #cu_n) | (CSE_y, #pe_n) | (CSE_z, #pr_n) |
|                       |                 | ...            | ...            | ...            |
|                       |                 | (CSE_x, #cu_p) | (CSE_y, #pe_p) | (CSE_z, #pr_p) |
|                       |                 | ...            | ...            | ...            |

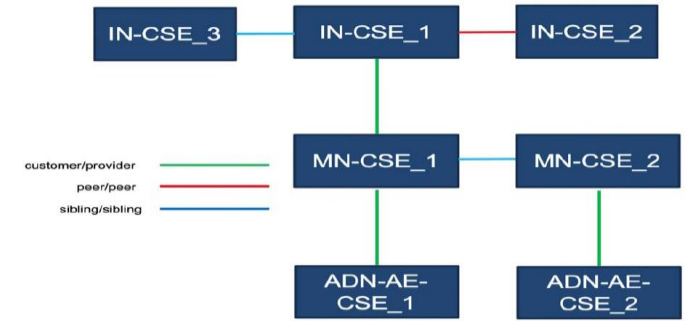

Figure 7.2.1-1: C2P and P2P and S2S CSE relationships

Table 7.2.6-2: Upgrading the adjacent SRT CSEs with the new y AE-THERMOMETERS

|             |                            |               |             |               |
|-------------|----------------------------|---------------|-------------|---------------|
| CSEcust1    | URI                        | CSE CUSTOMERS | CSE PEERS   | CSE PROVIDERS |
| THERMOMETER | <u>URI v, URI w</u>        | ...           | ...         | (CSE, #_+y)   |
| CSEcust2    | URI                        | CSE CUSTOMERS | CSE PEERS   | CSE PROVIDERS |
| THERMOMETER | <u>URI z</u>               | ...           | ...         | (CSE, #_+y)   |
| CSEpeer     | URI                        | CSE CUSTOMERS | CSE PEERS   | CSE PROVIDERS |
| THERMOMETER | <u>URI a</u>               | ...           | (CSE, #_+y) | ...           |
| CSEprov     | URI                        | CSE CUSTOMERS | CSE PEERS   | CSE PROVIDERS |
| THERMOMETER | <u>URI b, URI c, URI d</u> | (CSE, #_+y)   | ...         | ...           |

## 5 Use Case - Semantic discovery in presence of a "Network" of M2M Service Providers (M2MSP)

- 1) *Advanced Semantic Discovery shall support queries written with specific Domain Ontologies, e.g. SAREF.*
- 2) *Advanced Semantic Discovery shall support semantic reasoning between the baseline oneM2M ontology and the identified domain specific ontologies, e.g. SAREF. As example, if a query is looking for a oneM2M device observing Celsius Temperature, then the Advanced Semantic Discovery would potentially return a SAREF temperature sensor.*
- 3) *Advanced Semantic Discovery shall provide Capabilities to identify Multiple Set of Targets, and a Multiplicity of Searches (e.g. by setting parameters or filters).*

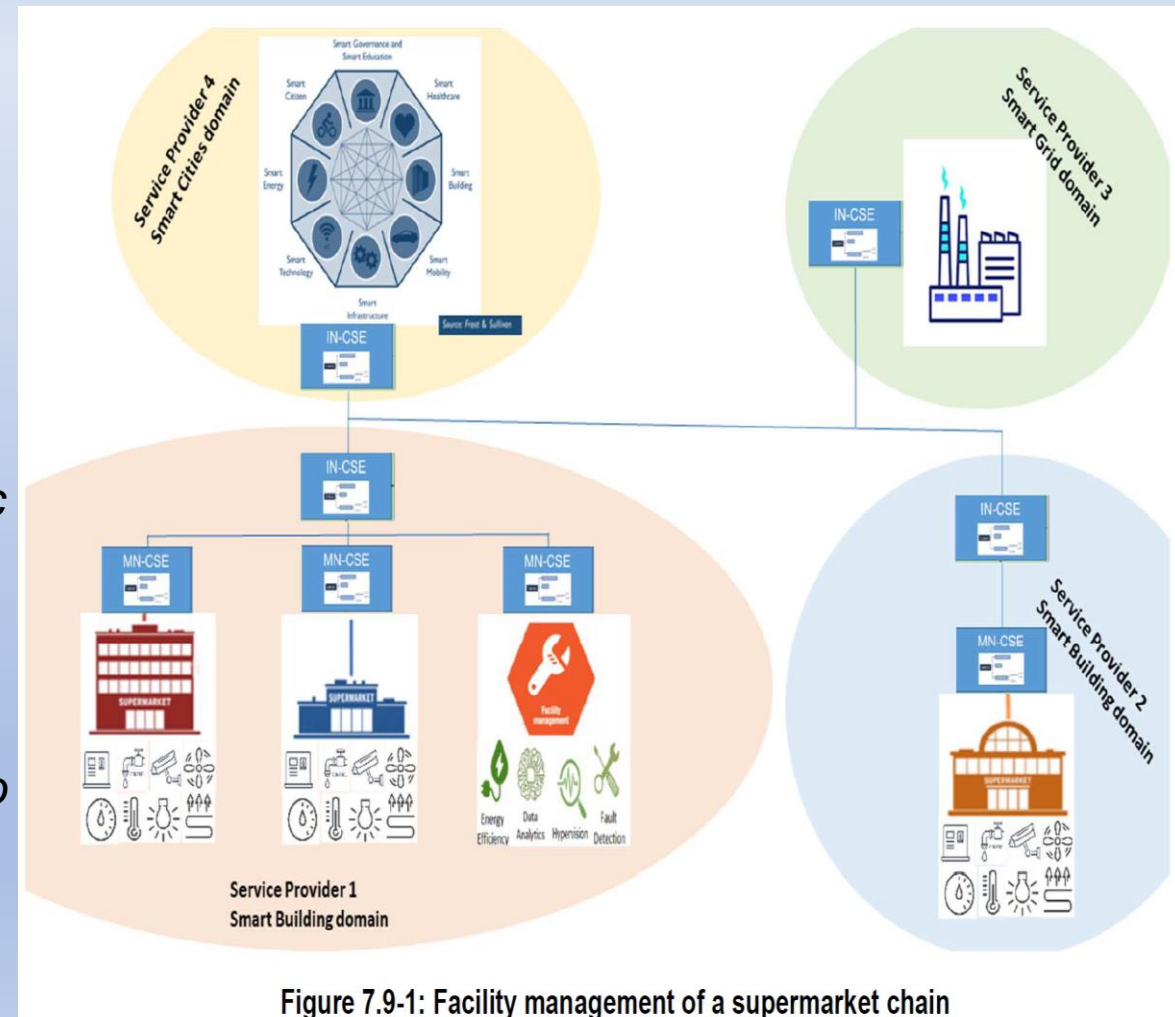

Figure 7.9-1: Facility management of a supermarket chain



TECHNICAL REPORT

SmartM2M;  
Study for oneM2M  
Discovery and Query use cases and requirements

# 5 Use Case - Semantic discovery in presence of a "network" of M2M Service Providers (M2MSP)

## Use Case - Healthcare Network and Clinical Knowledge Administration

This use case looks at the Semantic Discovery Requirements through a Networking Environment between People with Disease (Patients), the Elderly, who want to live an independent life while remaining in their homes, Special Invalid People with a high risk of falling in their homes, Doctors/Care taking People, People practicing fitness exercises to improve their health, and Institutions/Organizations, who manage a Clinical Knowledge & Information Data Basis or Analyses of Patient Data.

### Ageing and Living well and Epigenetics?!?!

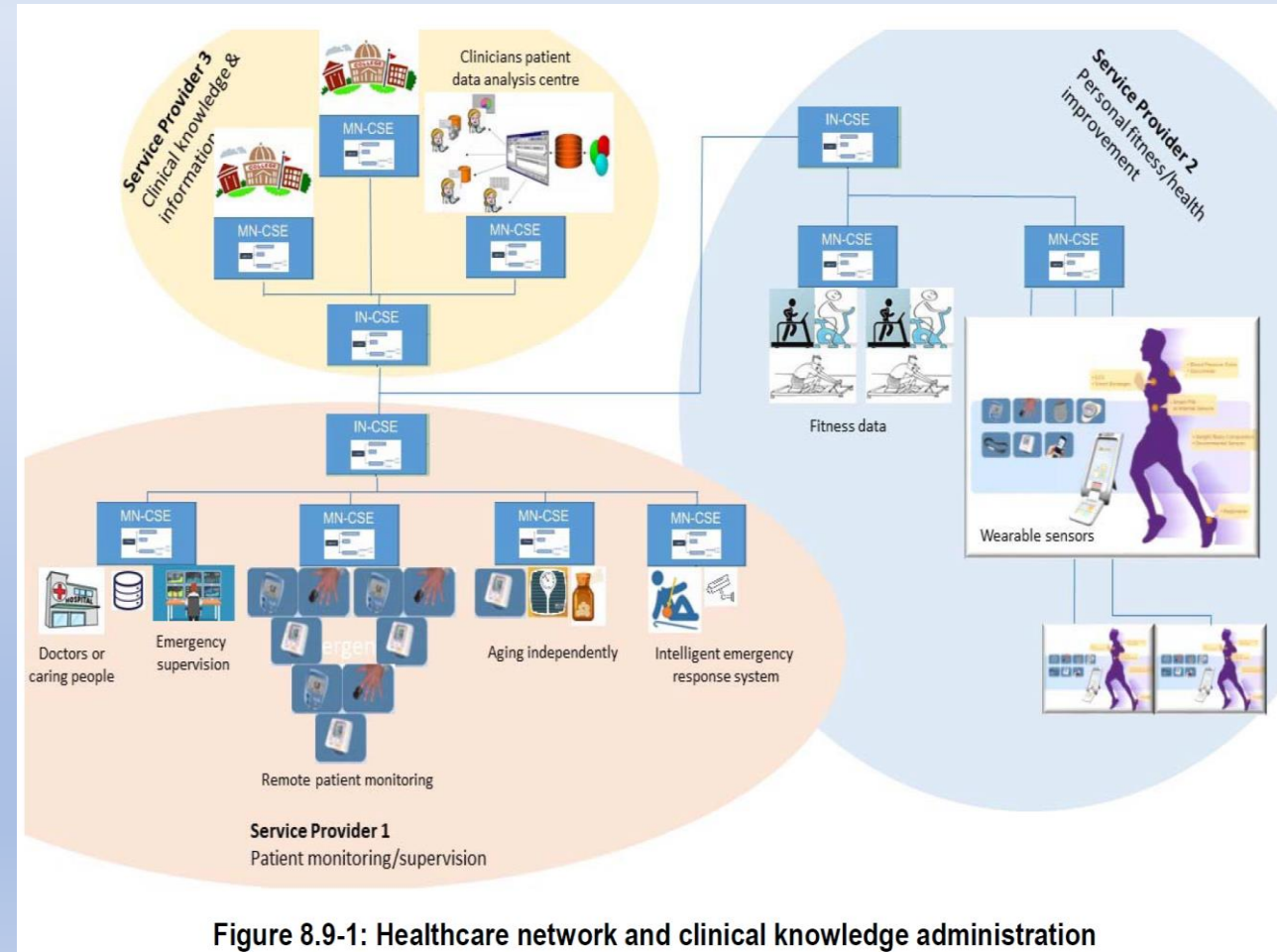

Figure 8.9-1: Healthcare network and clinical knowledge administration



# oneM2M Semantic Support and Discovery - Ontology Mapping

The Ontology Mapping Task performed by

- => Create Operation or
- => Update Operation against an
- => *<ontologyMapping>* resource on a Hosting CSE.

A Retrieve operation against the same *<ontologyMapping>* resource shall be used to get the result of ontology mapping. A Delete operation against a *<ontologyMapping>* resource shall follow the basic procedure as specified in clause [1].

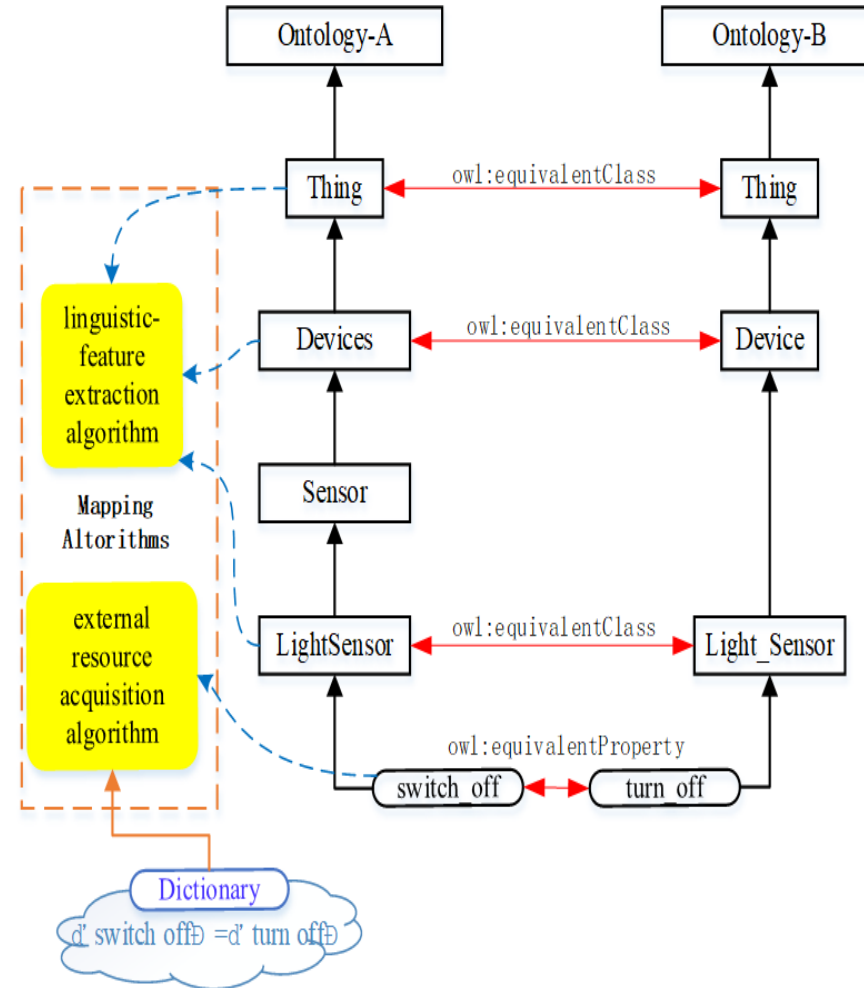

Figure 6.10.2-2: Example of the mapping result between ontology A and ontology B

# ETSI CIM NGSI-LD API - Context Information Management Next Generation System Interface Linked Data API

The Goal of the ETSI ISG on Context Information Management is to issue TSs to enable multiple Organisations to develop interoperable SW implementations of a cross-cutting Context Information Management (CIM) Layer.

## The CIM Layer should enable Applications to

- Discover,
- Access,
- Update and
- Manage

Context information from many different sources, as well as publish it through interoperable Data Publication Platforms.

**Phase 1** - detect and describe the Standardization Gaps.

**Phase 2** - Developing ISG CIM Group Specifications in Phase 2 will subsequently fill these gaps. It is expected that an extension of the RESTful binding of the OMA NGSI API involving expression using JSON-LD could aid interoperability, so this and potentially other extensions will be considered.

## Context Information Management Layer

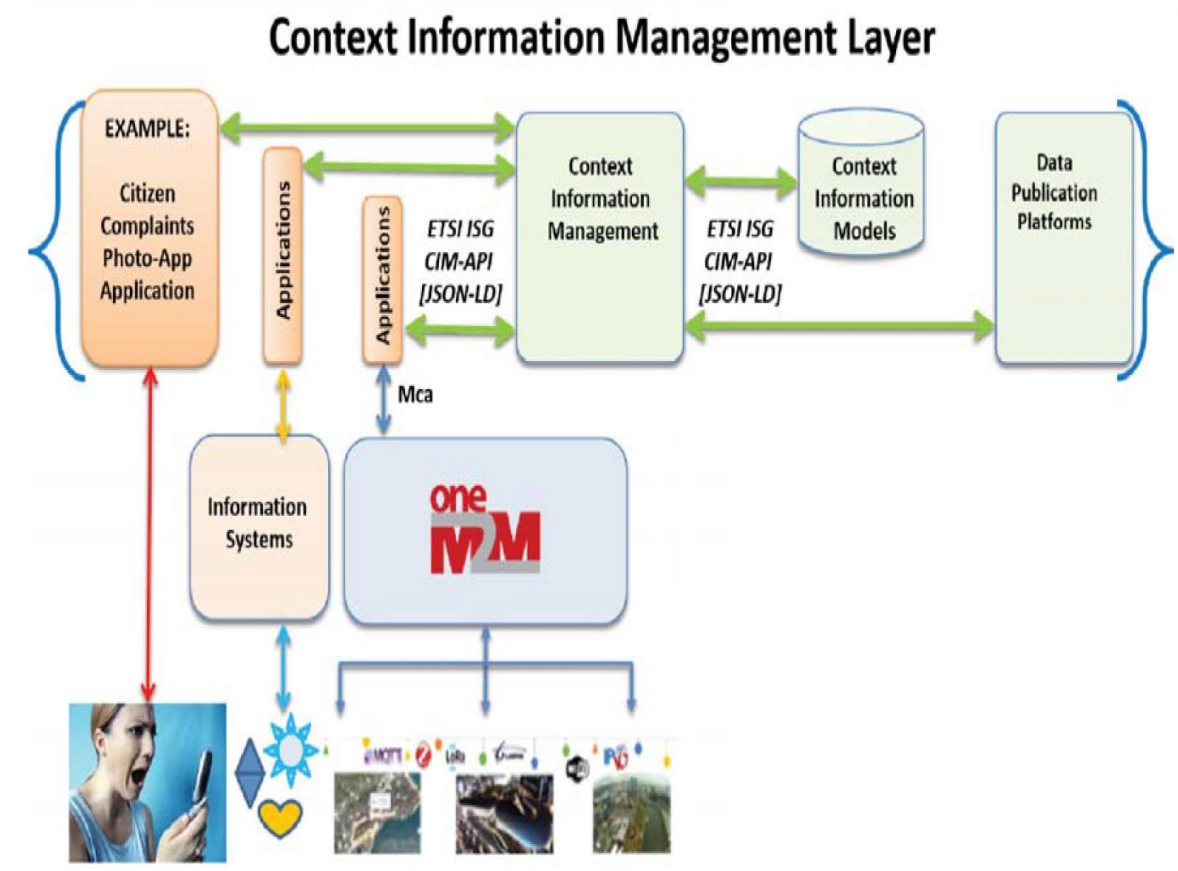



# ETSI CIM NGSI-LD API - Context Information Management Next Generation System Interface Linked Data API

## Context Information Management CIM - NGSI-LD API

The CIM API allows Users to:

- Provide,
  - Consume
  - Subscribe
- > **Context Information**

Close to Real-time Access to Information coming from many different Sources (not only IoT Data Sources).

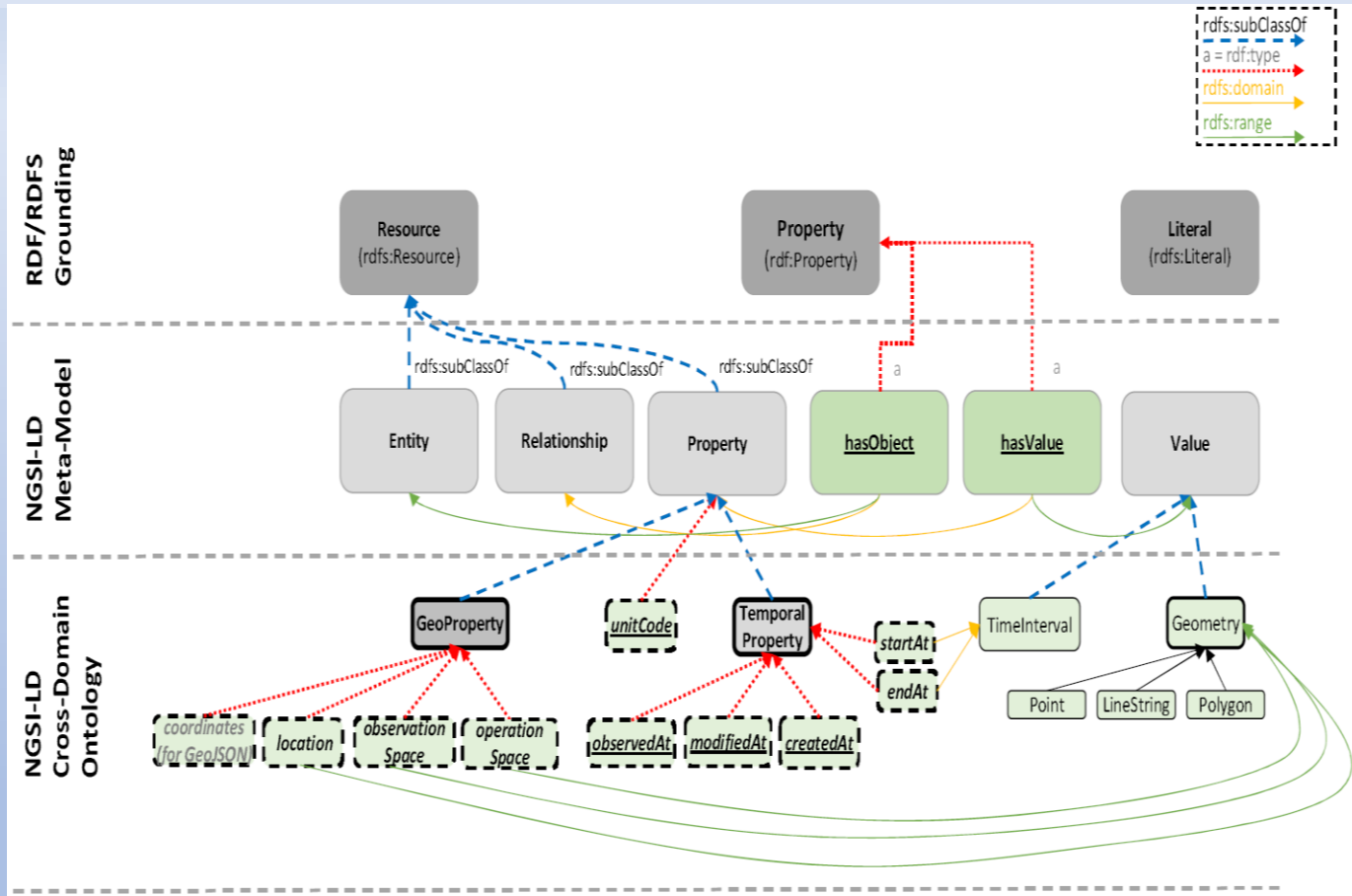

Figure 4.2.3-1: NGSI-LD Core Meta-Model plus the Cross-Domain Ontology







# Commercial

# ML Classification

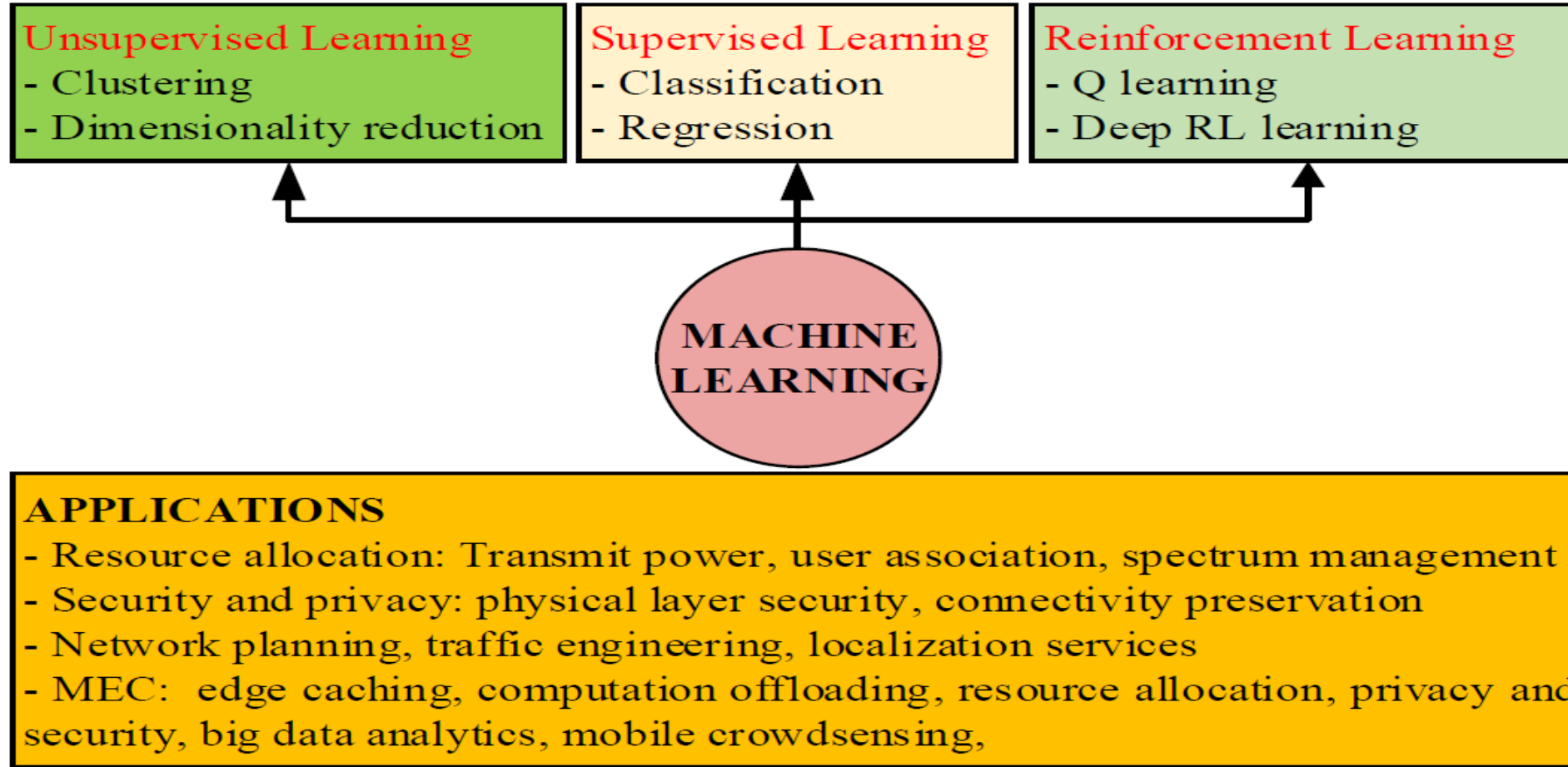
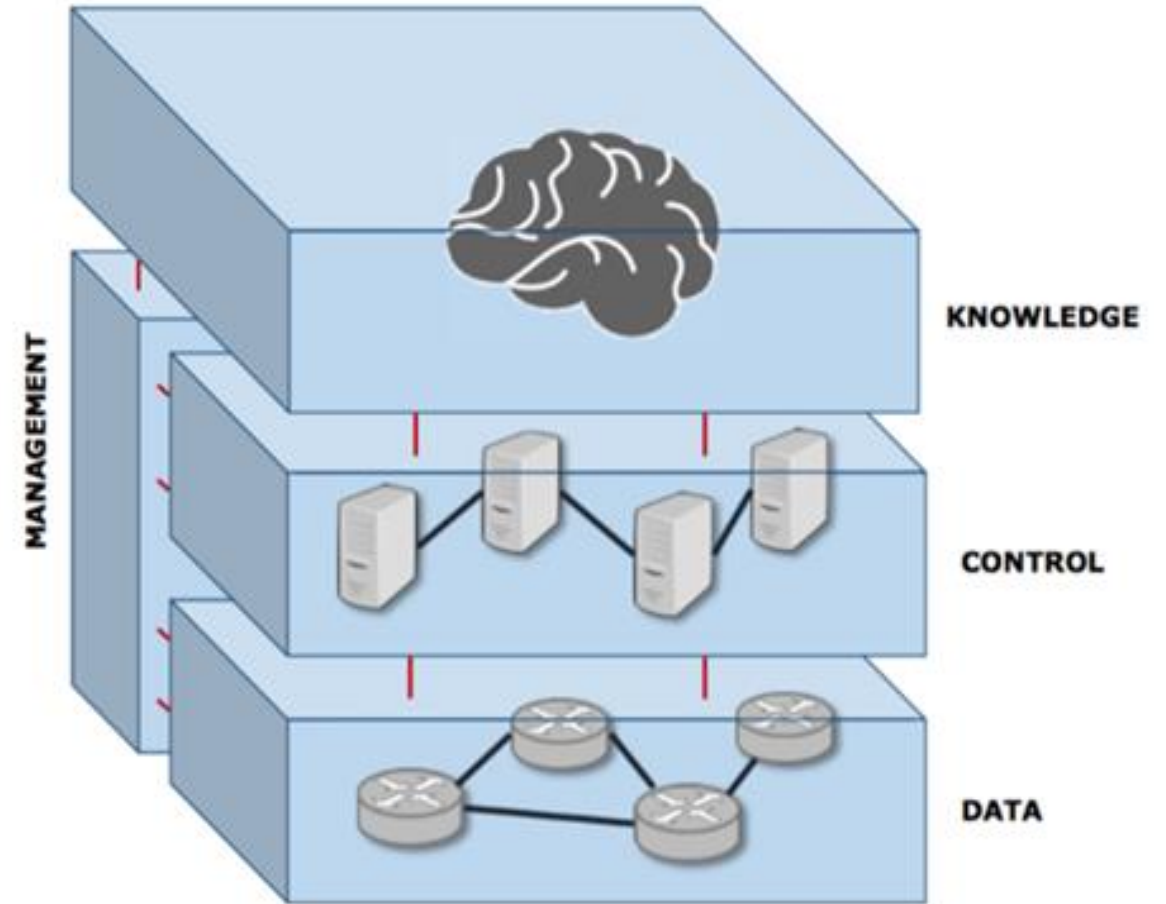
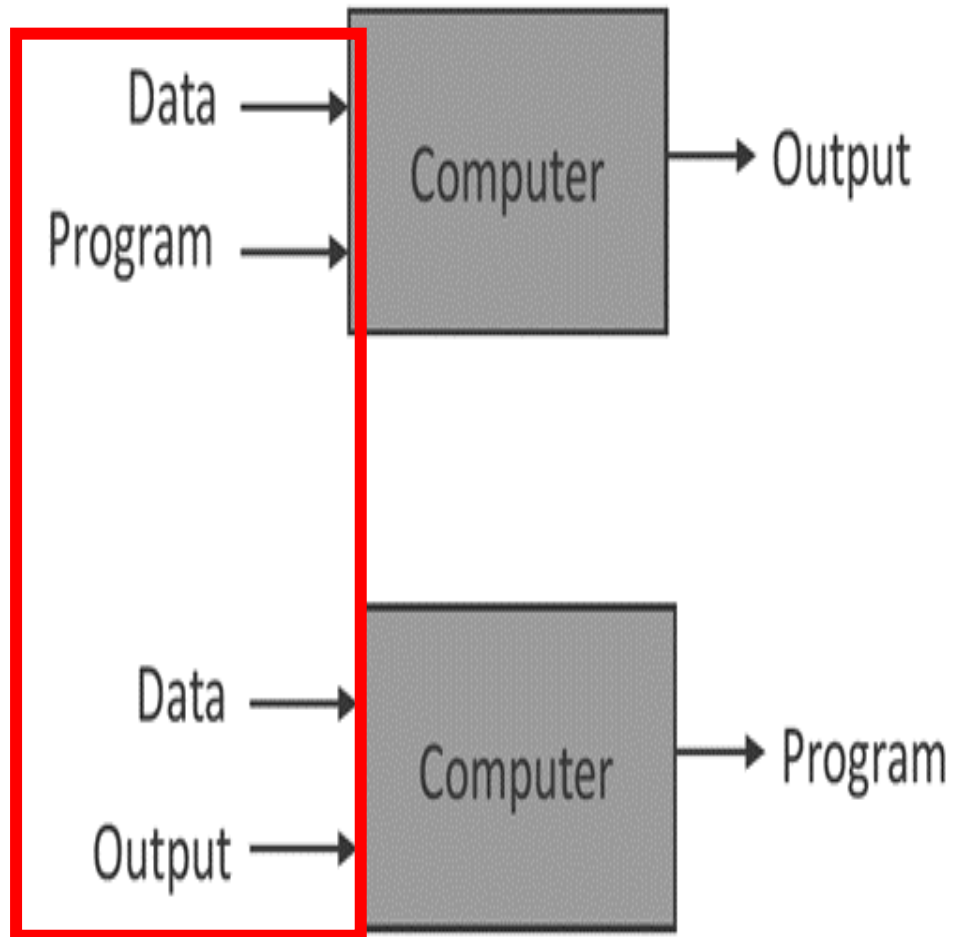

Fig. 11: Classification and applications of ML in mobile and wireless networking.



## KDN – TMF



## Data Processing Chain Machine Learning - (ML)

The life cycle for ML can be considered to have the following Stages:

- 1) Data acquisition
- 2) Data curation
- 3) Model design
- 4) Software Build
- 5) Train**
- 6) Test
- 7) Deployment
- 8) Updates

Stages 4), 5) and 6) (Build, Train, Test) can together be considered as an iterative implementation cycle.

**In the ML lifecycle, the Training phase can be considered as the most critical**, since it is this stage that establishes the baseline behaviour of the system.

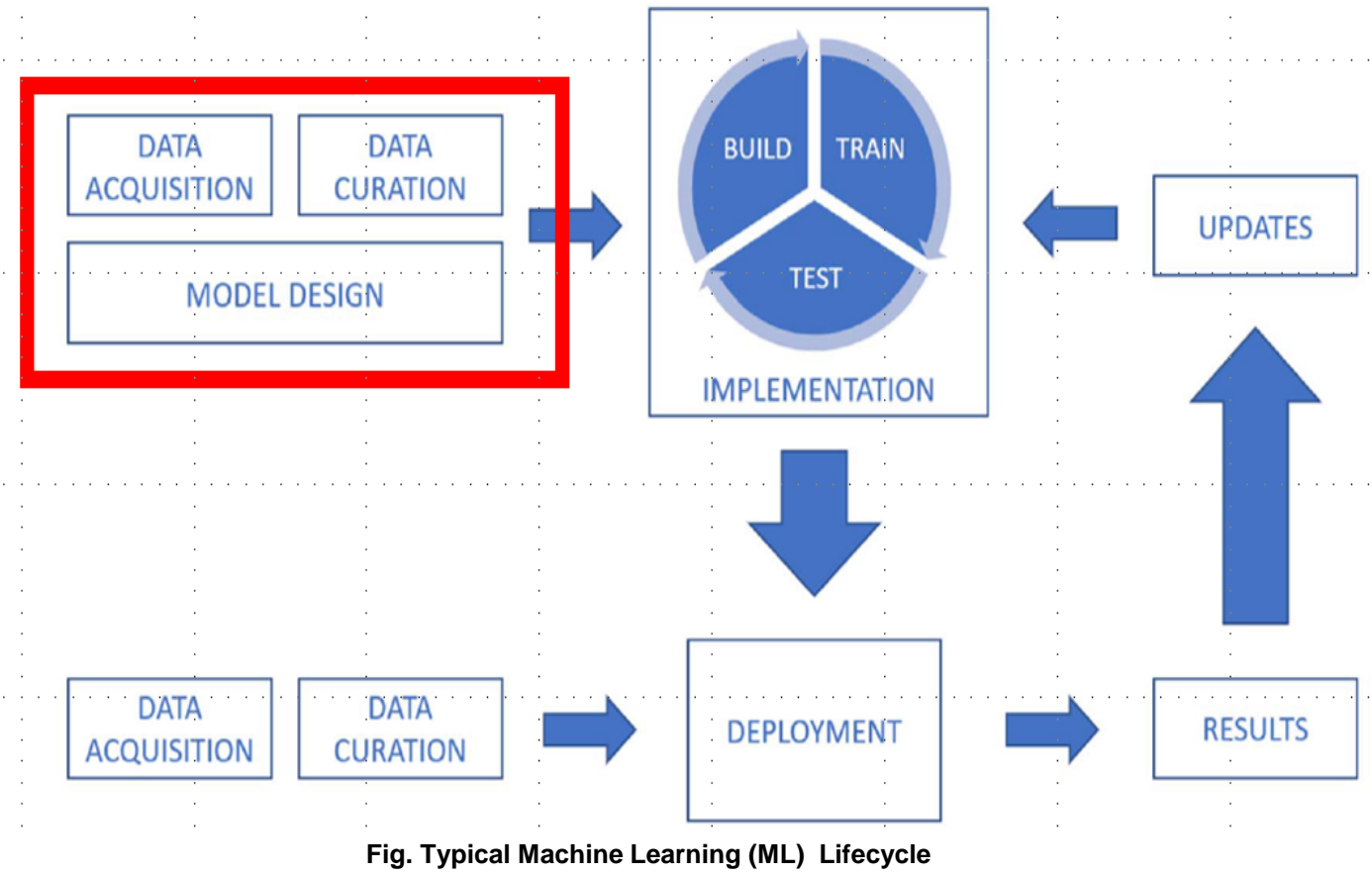
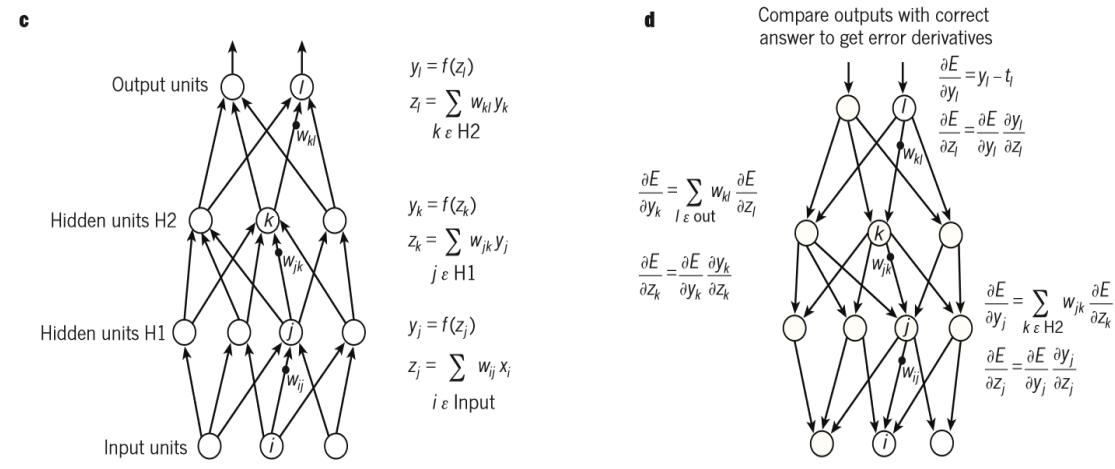
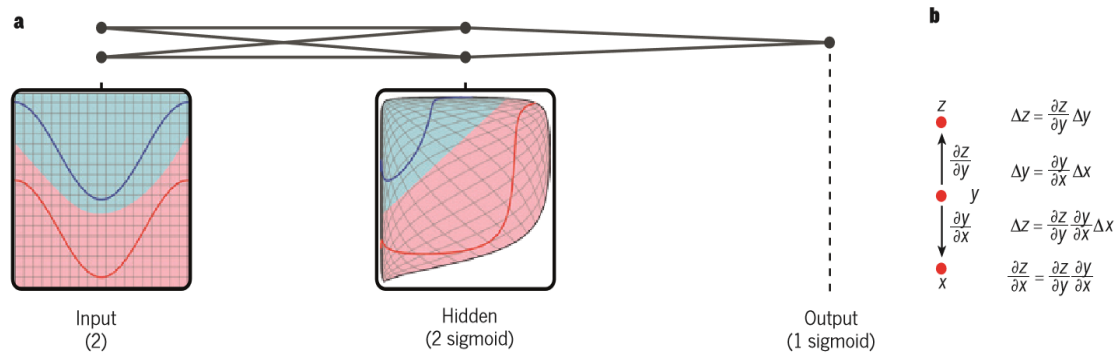
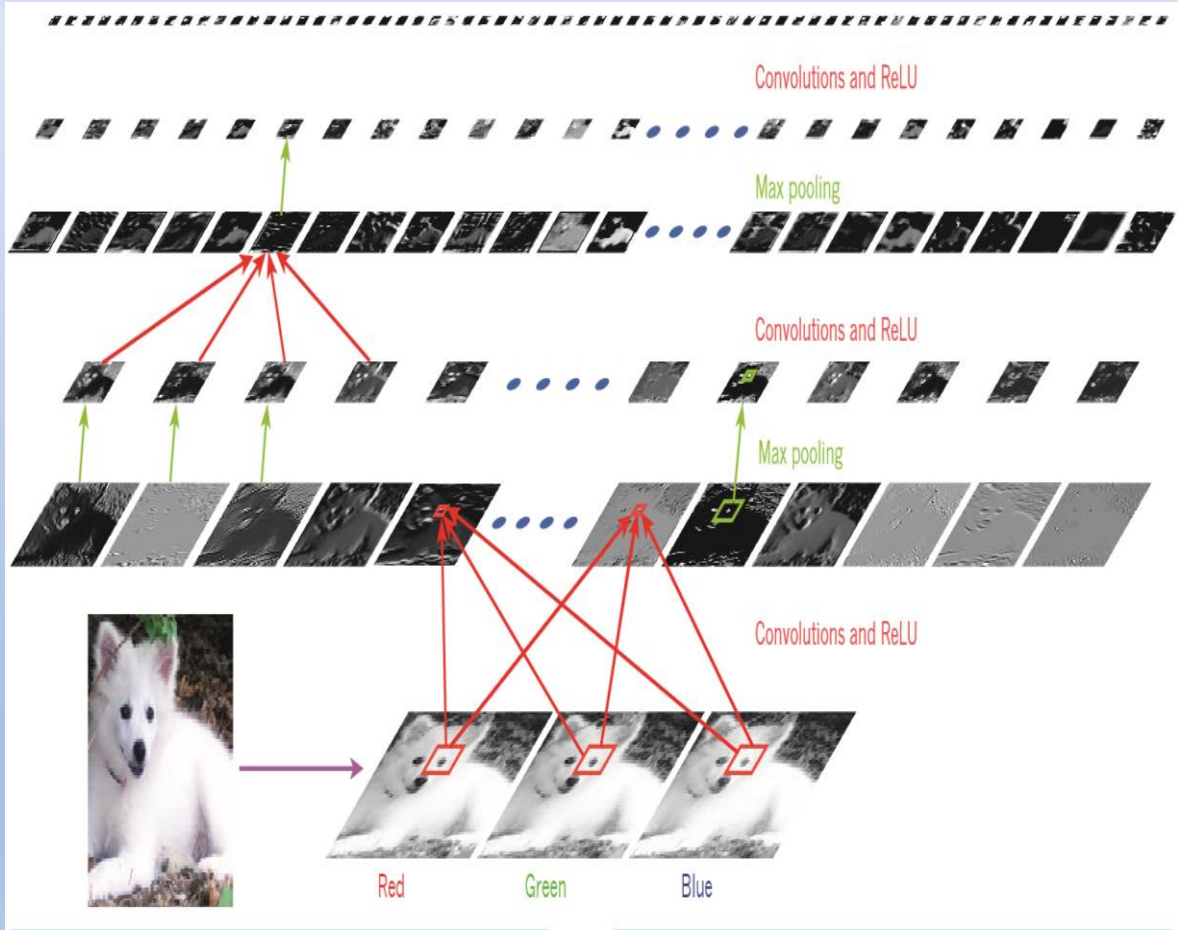

Fig. Typical Machine Learning (ML) Lifecycle

Table 1: Challenges in confidentiality, integrity and availability in the machine learning lifecycle

| Clause | Lifecycle Phase  | Issues                                   |
|--------|------------------|--|
| 4.3.2  | Data Acquisition | Integrity                                |
| 4.3.3  | Data Curation    | Integrity                                |
| 4.3.4  | Model Design     | Generic issues only                      |
| 4.3.5  | Software Build   | Generic issues only                      |
| 4.3.6  | Train            | Confidentiality, Integrity, Availability |
| 4.3.7  | Test             | Availability                             |
| 4.3.8  | Deployment       | Confidentiality, Integrity, Availability |
| 4.3.9  | Upgrades         | Integrity, Availability                  |



## Self-Transfer Optimization Network

### Deep Reinforcement Learning Framework

A DRL framework similar to the one proposed in [i.60] is considered, but modified in such a way that it learns the mapping between the network environment measurements (given as inputs) and the optimization actions/decisions (given as outputs), where the corresponding system performance metrics are mapped as rewards.

The DRL model consists of at least convolutional layers and fully connected layers, where the convolutional layers are used to capture the temporal and spatial correlations of the network environment, while the fully connected layers are used for reducing the dimension to the required dimension of the output actions. Figure 28 gives an example of the DRL model with two convolutional layers and two fully connected layers.

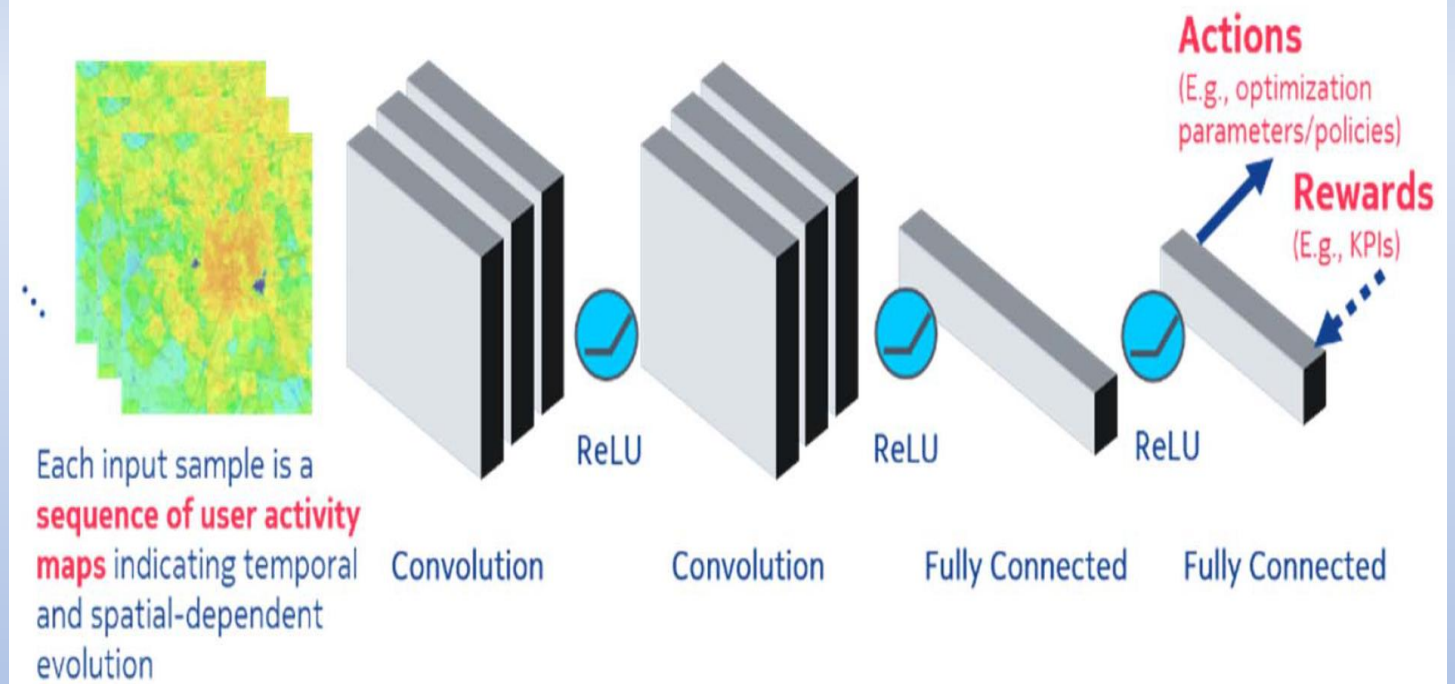
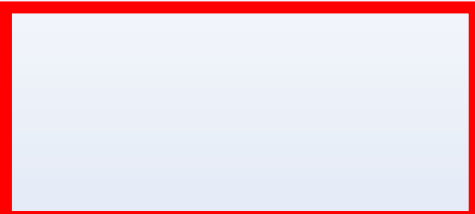
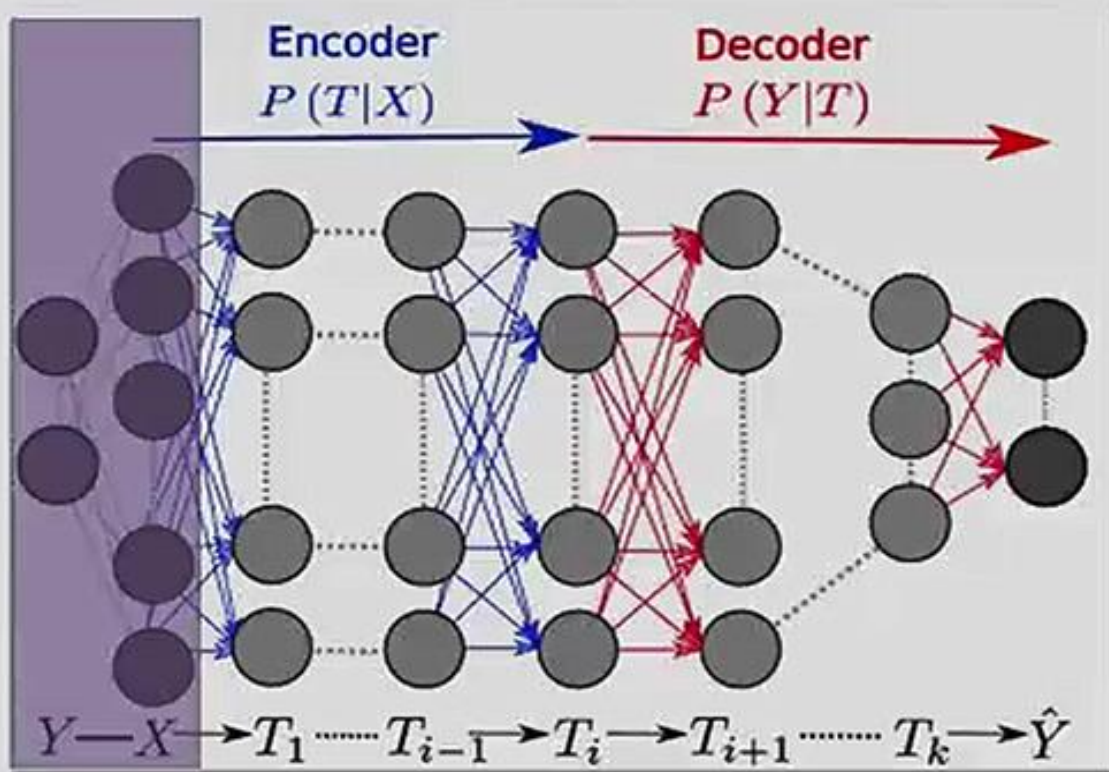

Fig 28 An example of DRL Deep Reinforced Learning Network





## Each layer is characterized by its Encoder & Decoder Information



### Theorem (Information Plane):

For large typical  $X$ , the sample complexity of a DNN is completely determined by the encoder mutual information,  $I(X;T)$ , of the last hidden layer; the accuracy (generalization error) is determined by the decoder information,  $I(T;Y)$ , of the last hidden layer.

The complexity of the problem shifts from the decoder to the encoder, across the layers...



# ETSI ENI Architecture for Closed -Loop Network Operations & Management enabled by AI/ML Techniques

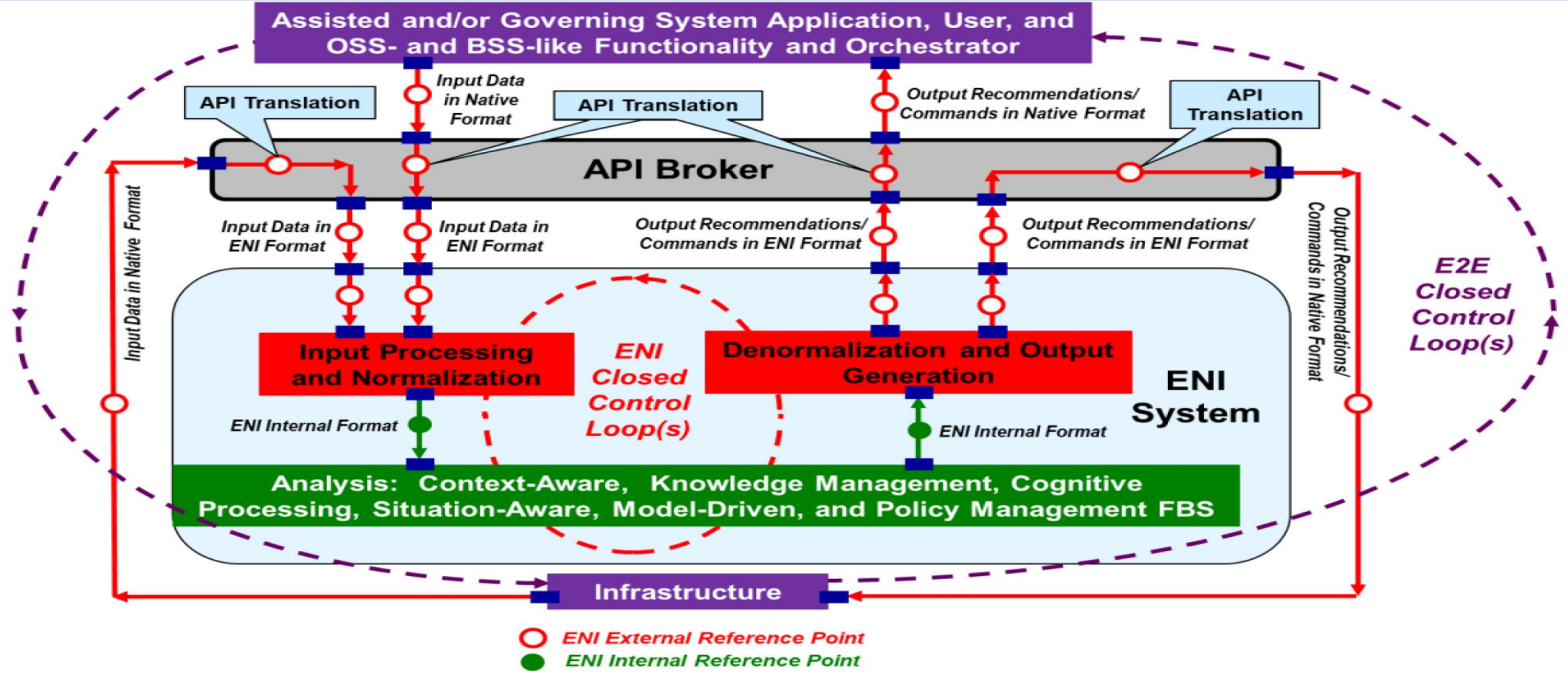

Figure 3: High-Level Functional Architecture of ENI when an API Broker is used

# The Big Shift - from "Caveat Emptor" to "Caveat Venditor" - 1

THE MARKET FOR "LEMONS":  
QUALITY UNCERTAINTY AND THE  
MARKET MECHANISM \*

GEORGE A. AKERLOF

I. Introduction, 488. — II. The model with automobiles as an example, 489. — III. Examples and applications, 492. — IV. Counteracting institutions, 499. — V. Conclusion, 500.

## The Big Shift

Caveat Emptor

"Buyer Beware"



Caveat Venditor

"Seller Beware"

**Information Parity**  
(the primary reason for the shift)

B

S



Buyer has information

Seller has information

**Caveat Venditor**

## When Information is Ubiquitous:

shift from **Information Inequality** to **Information Parity**

**No longer enough**

just to be able to Answer to Questions on Product/Solution/ Services  
and/or present Platforms, Solutions, Services, Standards ...

# The Big Shift - from "Caveat Emptor" to "Caveat Venditor" - 2

## The Big Shift

Caveat Emptor

Caveat Venditor

"Buyer Beware"

"Seller Beware"



Information Parity  
(the primary reason for the shift)

B

S



Buyer has information

Seller has information

Caveat Venditor

## When Information is Ubiquitous

The Value of undertaking the role of "Unbiased Business Partner"

Shift in assigned importance from **"Problem - Solving"**  
to  
**"Problem-Identification/ Finding"**

Ask the **"Right Questions"**

- to Identify Current Issues/Problems, curate the Vast Amount of Information &
- **Ability to Hypothesize/Clarify on Future** Problems, Inter-Dependencies
- **Outline Future Multi-Vendor Inter- Operability & Scalability**
- **Ground for Personalized, Business Model and Agile Service Deployment.**

# The Big Shift - from "Caveat Emptor" to "Caveat Venditor" - 3

## The Big Shift

Caveat Emptor

Caveat Venditor

"Buyer Beware"

"Seller Beware"

Information Parity  
(the primary reason for the shift)



To see what the Problem is before jumping in to Resolve it

Problem Solving Approach turns upside down Two (2) "Traditional Sales Skills:

### A) From "Access Information" to "Curating Information":

- Sorting - out through massive amount of Data
- Presenting the most Relevant & Clarifying Aspects

### B) From "Answering Questions" to "Asking Questions" to:

Uncover    =>    Possibilities  
                  Surfacing Latent Issues  
                  Unexpected problems

C) Apply "Contrast Principle" (R. Cialdini) & move from  
"Upselling" to "Upserving"

## Most Important Question:

**"Compared to What"? => Value**



# GAIN Model and Fallacies of Data - 2

## Three (3) Fallacies of Data

### 1. The Fallacy of Active vs Passive Data.

Growing companies start to **generate Operations-related Data (Active Data)**, which can seduce with its apparent objectivity.

### 2. The Fallacy of Surface Growth

In consumer relationships, Corporations focus their energies on driving growth by selling to existing Customers additional products.

### 3. The Fallacy of Conforming/Non-Conforming Data

focus on generating data that conforms to pre - existing notions, that inherently hinders/blinds from emerging/new opportunities beyond their perspective.

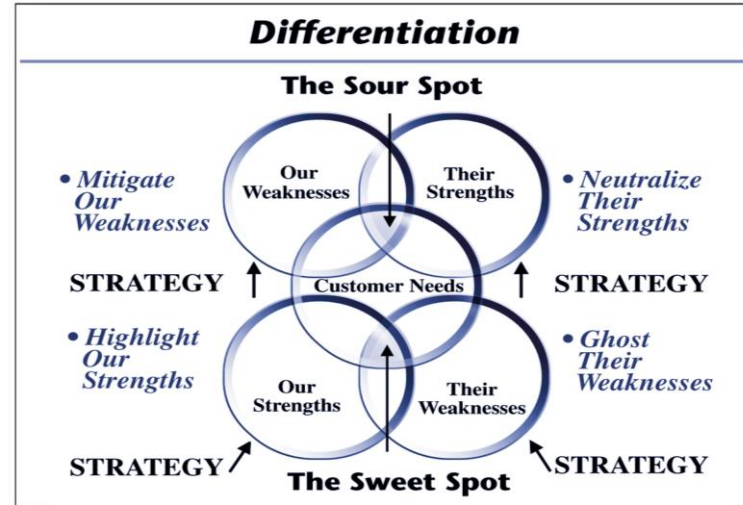

Positive (Sweet Spot) and negative (Sour Spot) differentiation exists only in the context of the customer's needs. Then Middle and Endgame strategies are implemented to grow the Sweet Spot and shrink the Sour Spot.



# B2C/B2B Technology Adoption Phases - Business Model

1. Engage Users
2. Develop Traffic
3. Identify the Loyal Users
4. Monetize (by charging the Loyal Users)

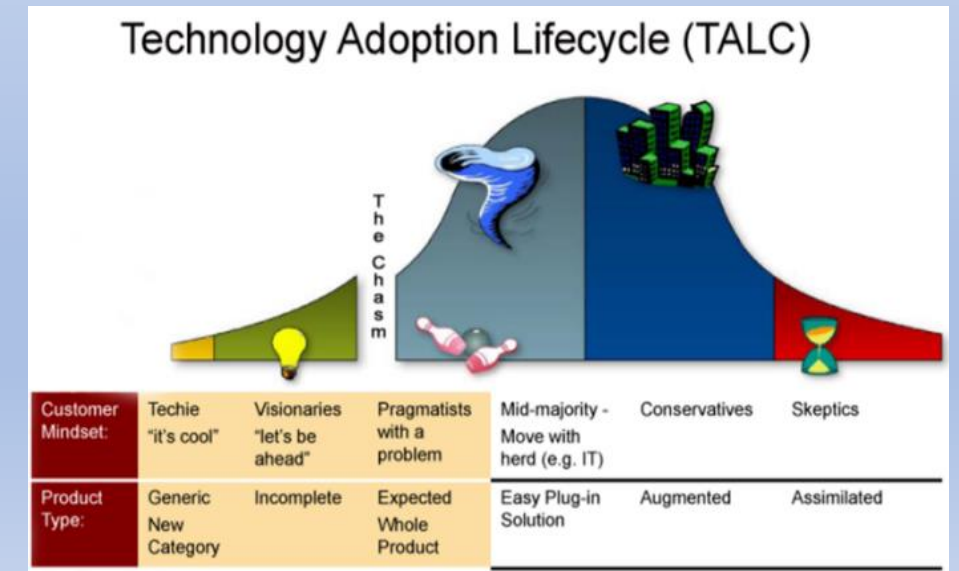
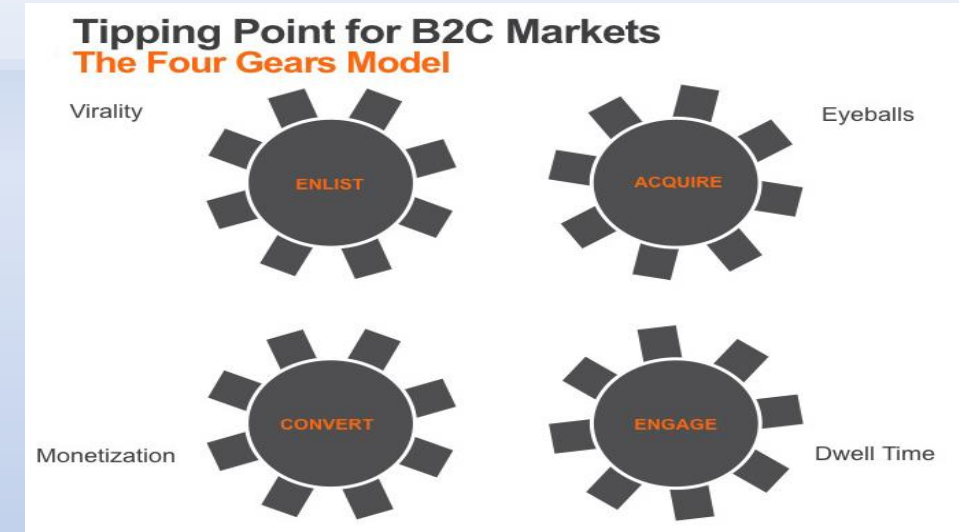

# Summary A - Video presentations:

1. "My APIs are the best". They are proprietary, but they are the best".
2. Repeating the mistakes done in the past while deploying New Technologies without changing the Business Framework
3. "Products are Packages of Emphasis from Technologies on the rise".



# Summary - B

1. How? or What/Why?



2. Package of Emphasis? or Emphasis?



3. Satisfy a Need? or Provides Progress?  
within Social and Emotional Context?





**Comments, Remarks, Questions?**

